

DOOR DETAIL

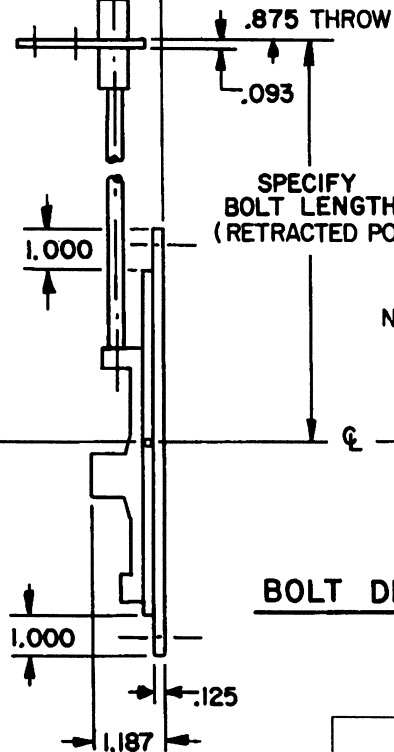

BOLT DETAILS

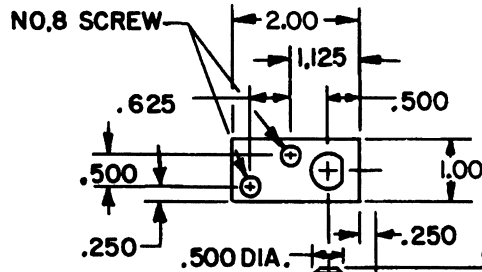
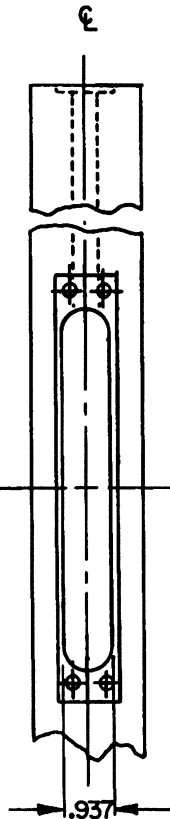
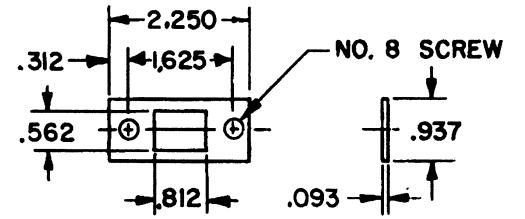

USE OF STRIKE OPTIONAL

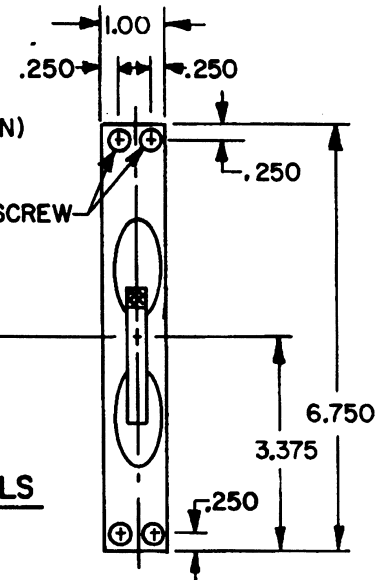

EFFECTIVE: 9-1-86 RA

DO NOT SCALE DRAWING

B. BALDWIN	
0600 FLUSH BOLT	
TEMPLATE NO. VARIATIONS	TEMPLATE NO
	A252