

DOOR DETAIL

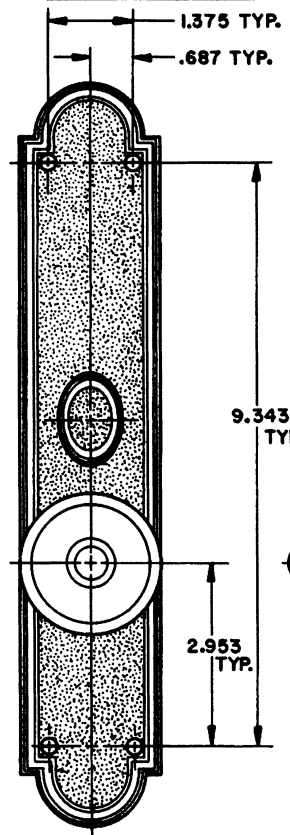

TRIM DETAIL (ENTR FUNCTION ILLUSTRATED)

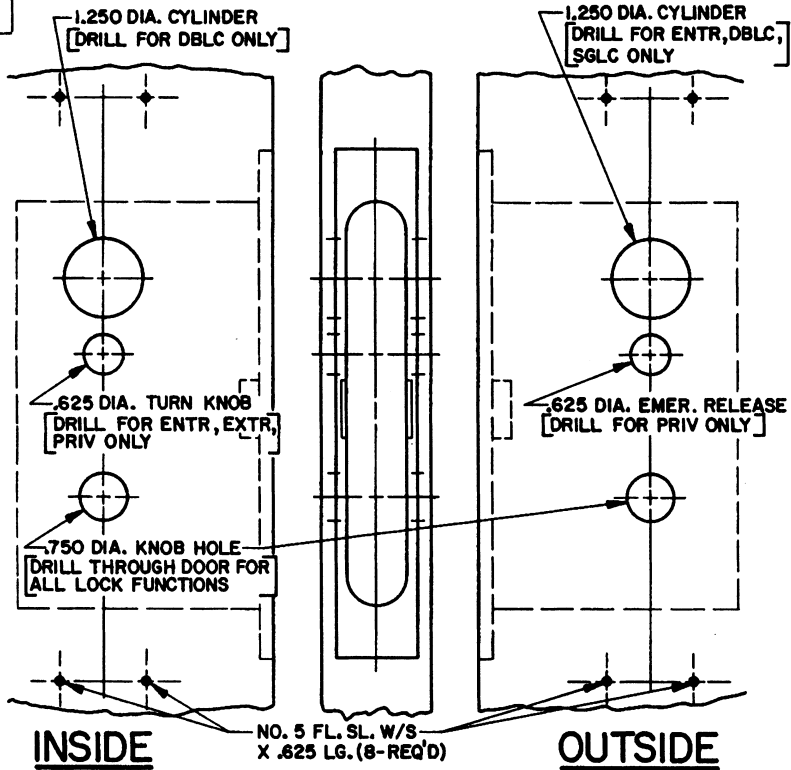
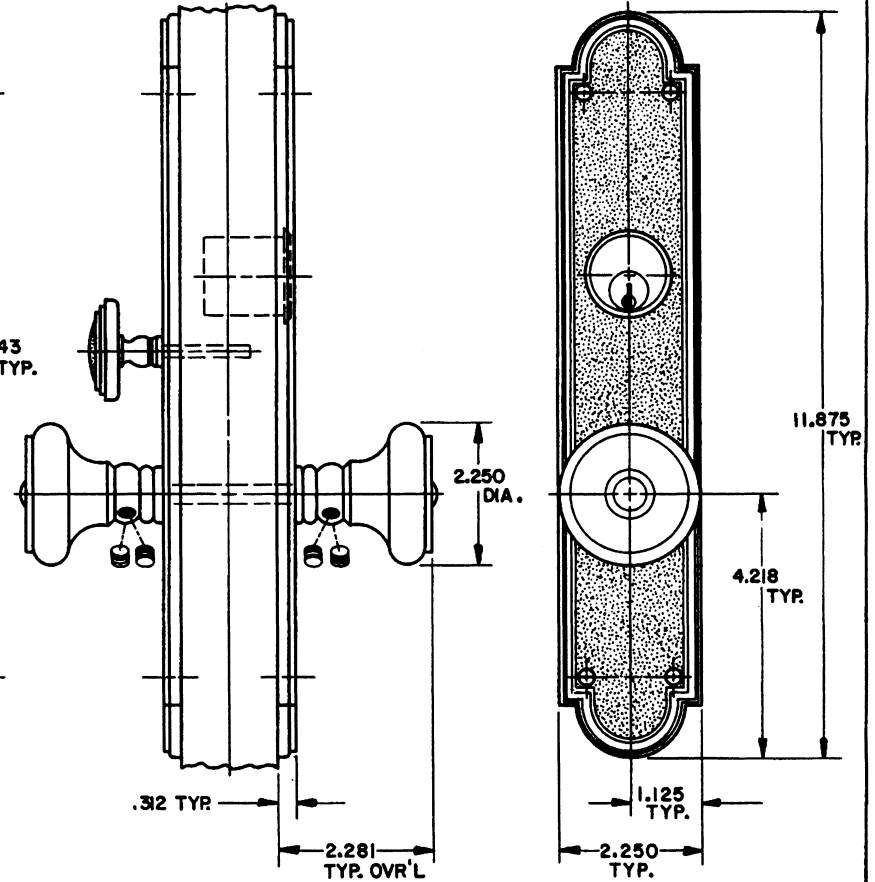

NOTE:

- 1.) FOR ADDITIONAL LOCK AND DOOR CUTOUT DIMENSIONS, SEE APPROPRIATE LOCK TEMPLATE.
- 2.) DRILL ALL HOLES HALF WAY THROUGH DOOR UNLESS OTHERWISE SPECIFIED.
- 3.) TO ENABLE EMERGENCY TRIM TO FUNCTION, THE TURN PIECE SPINDLE MUST BE CUT TO EXTEND NO FURTHER THAN HALF WAY THROUGH THE LOCK.
- 4.) INSTALLATION PLATES ARE NOT REQ'D FOR THIS TRIM.

EFFECTIVE: 2-1-90 P. 144-3

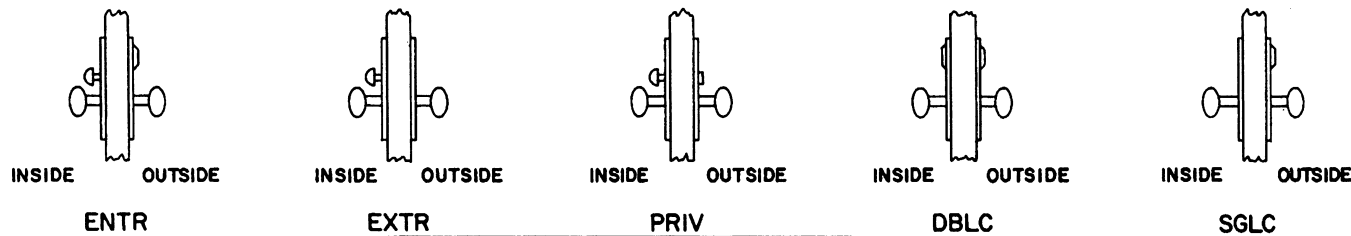

DO NOT SCALE DRAWING

B. BALDWIN	
6541 SAN FRANCISCO TRIM	
TEMPLATE NO. VARIATIONS	TEMPLATE NO.
	I541