

DOOR DETAIL

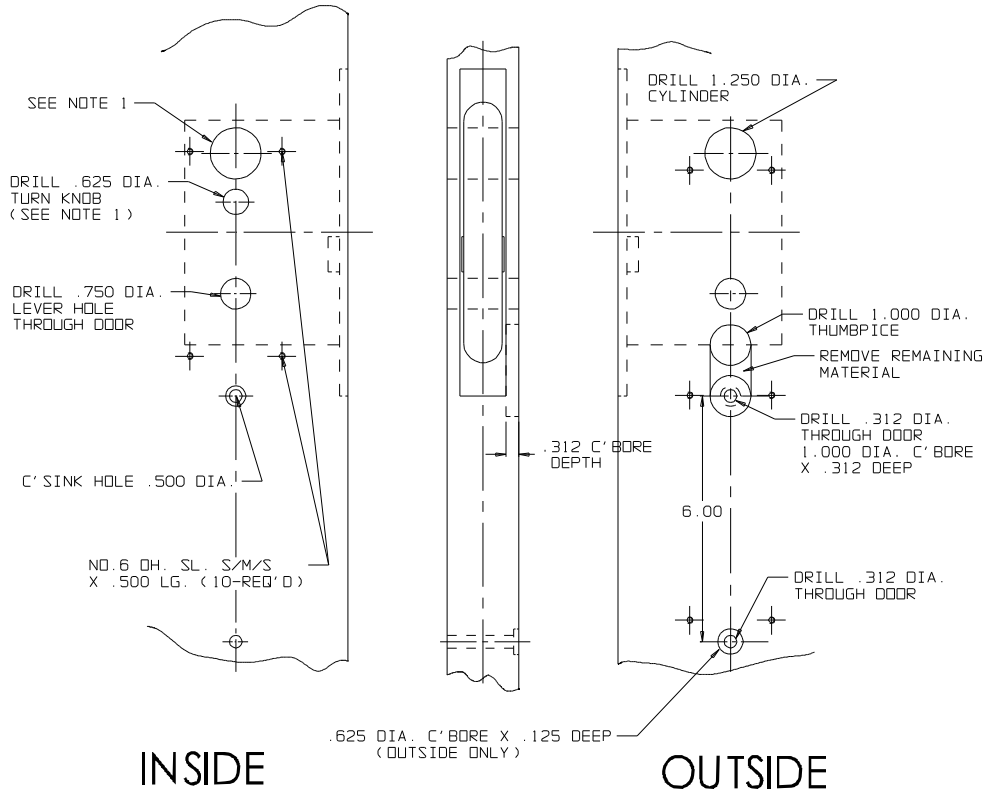

TRIM DETAIL

(ENTR FUNCTION ILLUSTRATED)

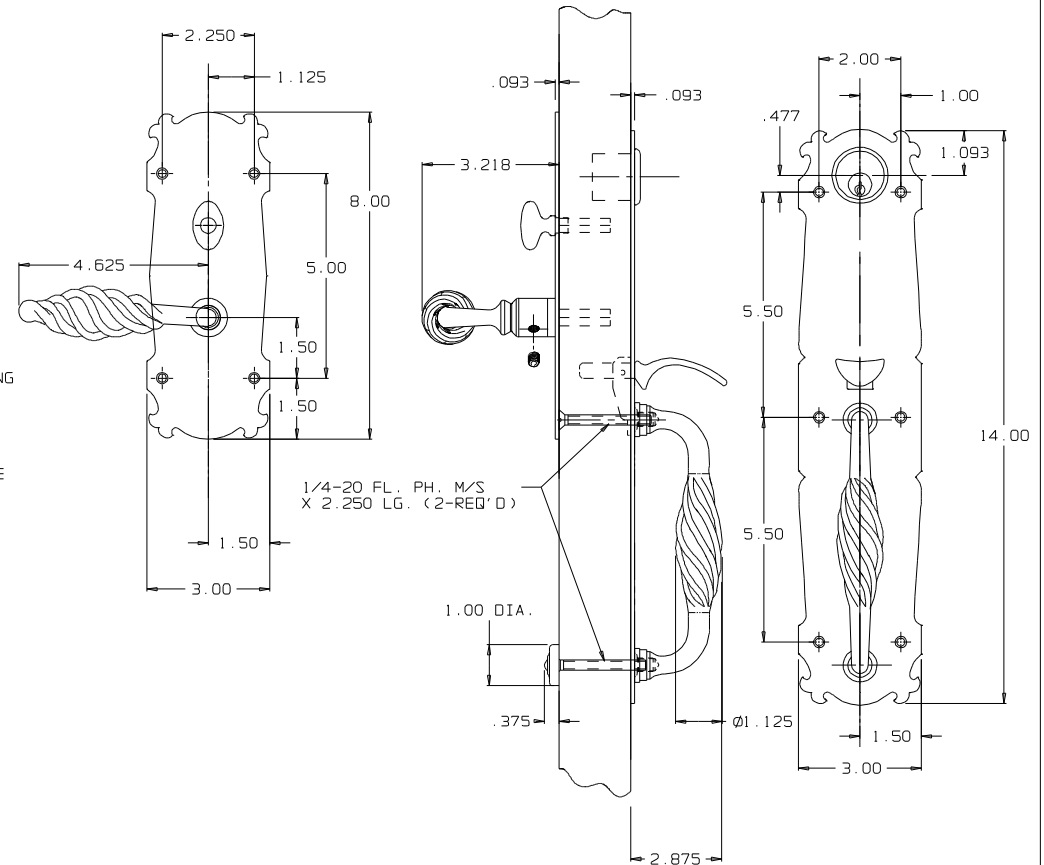

DO NOT SCALE DRAWING

 BALDWIN HARDWARE CORPORATION	
<h2>6984 BERKSHIRE TRIM</h2>	
TEMPLATE NO. VARIATIONS	TEMPLATE NO.
© 2003 BY BALDWIN HARDWARE CORPORATION	
<h1>I-133</h1>	

- NOTE:
- 1.) WHEN PREPARING DOOR FOR OBL FUNCTION, OMIT DRILLING OF .625 DIA. TURN KNOB HOLE. (INSIDE)
DRILL A 1.250 DIA. CYLINDER HOLE INSTEAD, USING THE SAME CENTER LINE AS THE OUTSIDE CYLINDER HOLE.
 - 2.) DRILL ALL HOLES HALF WAY THROUGH DOOR UNLESS OTHERWISE SPECIFIED.
 - 3.) FOR ADDITIONAL LOCK AND DOOR CUTOUT DIMENSIONS, SEE APPROPRIATE LOCK TEMPLATE.
 - 4.) INSTALLATION PLATES ARE NOT REQUIRED FOR THIS TRIM.