

DOOR DETAIL

LOCK DETAIL

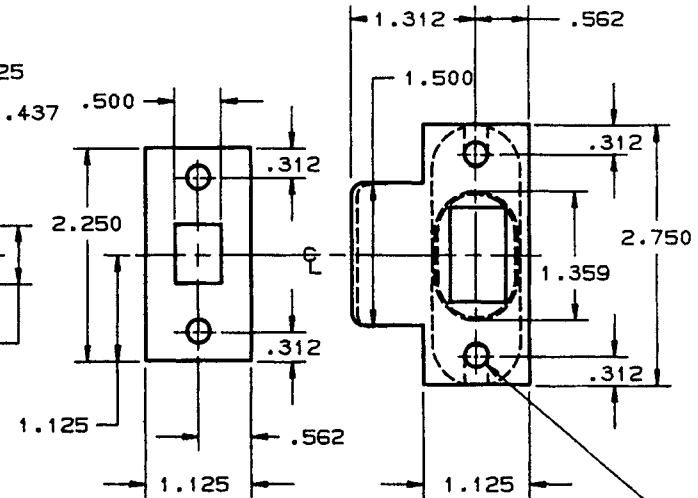
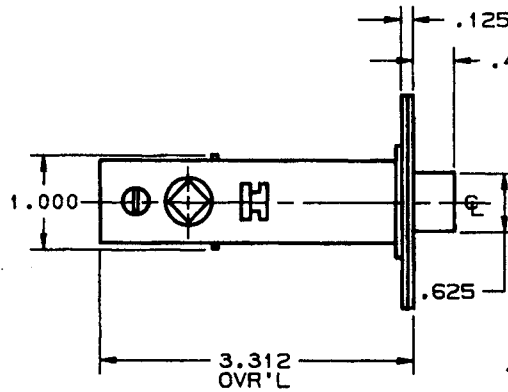
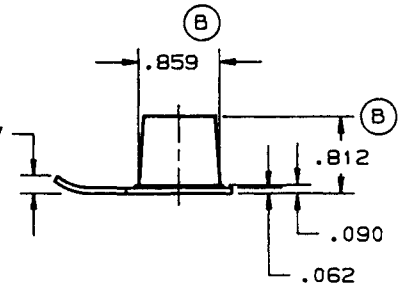
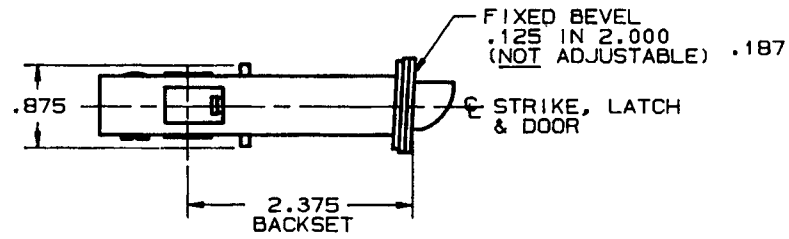
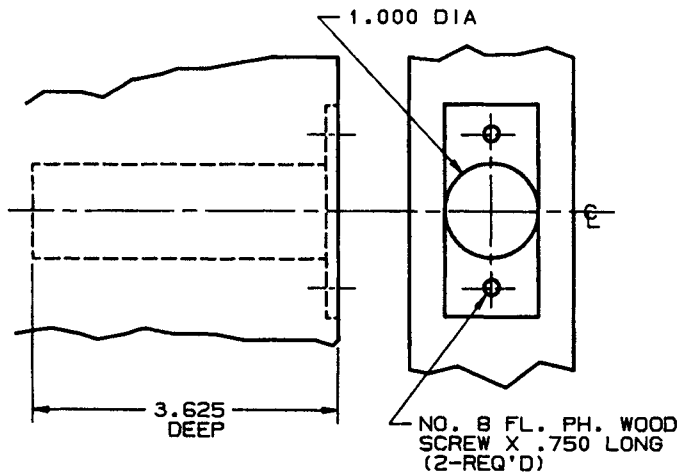

NO. 8 FL. PH. WOOD SCREW X .750 LONG (2-REQ'D)

NOTES

- 1.) SEE SPECIFIC TRIM TEMPLATE FOR ADDITIONAL DOOR CUTOUT DETAILS.
- 2.) FOR USE WITH BEVELED DOORS ONLY.
- 3.) 8515 IS MADE WITH A HEAVY DUTY SPRING DESIGNED FOR USE WITH LEVER HANDLES.
- 4.) LATCH IS NOT HANDED.

B. BALDWIN	
8512 AND 8515 TUBULAR LATCH	
TEMPLATE NO. VARIATIONS	TEMPLATE NO.
	F163(B)

DO NOT SCALE DRAWING

©1988 by Baldwin Hardware Corporation

EFFECTIVE: 5-1-88 RAL/g