

DOOR DETAIL

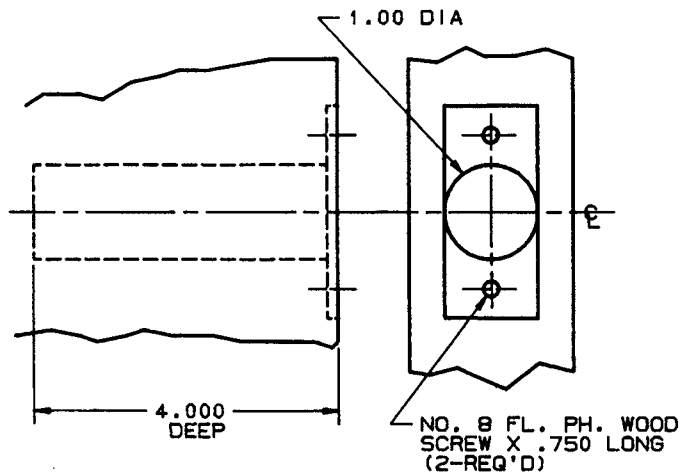

LOCK DETAIL

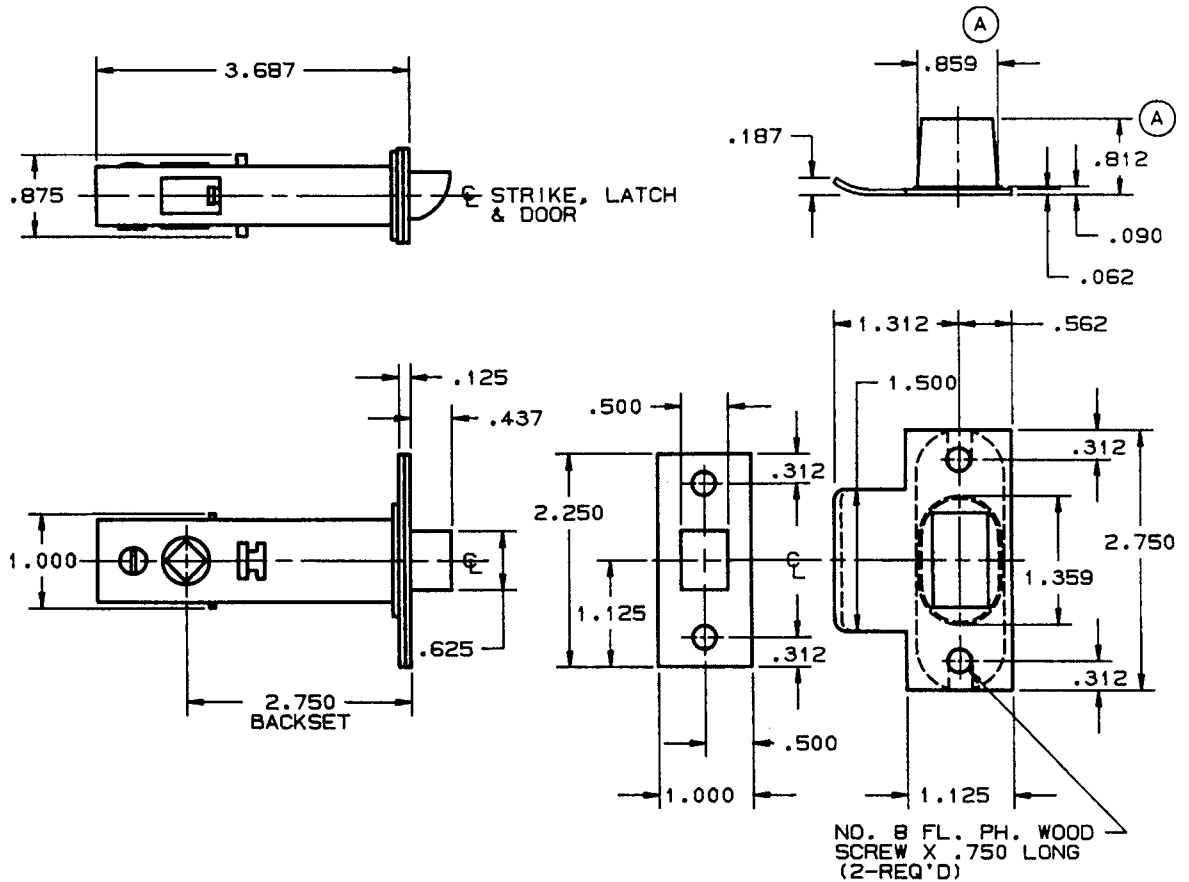

NOTE:
1. SEE SPECIFIC TRIM TEMPLATE FOR ADDITIONAL DOOR CUTOUT DETAILS.

BALDWIN	
8520 TUBULAR LATCH	
TEMPLATE NO. VARIATIONS	TEMPLATE NO.
	F170 (A)

EFFECTIVE: 5-1-88 R Adams

DO NOT SCALE DRAWING

©1988 by Baldwin Hardware Corporation