

DOOR DETAIL

DRILL FOR 8 X 8-32 FL PH COMBINATION SCREWS X .750 LONG (2-REQUIRED)

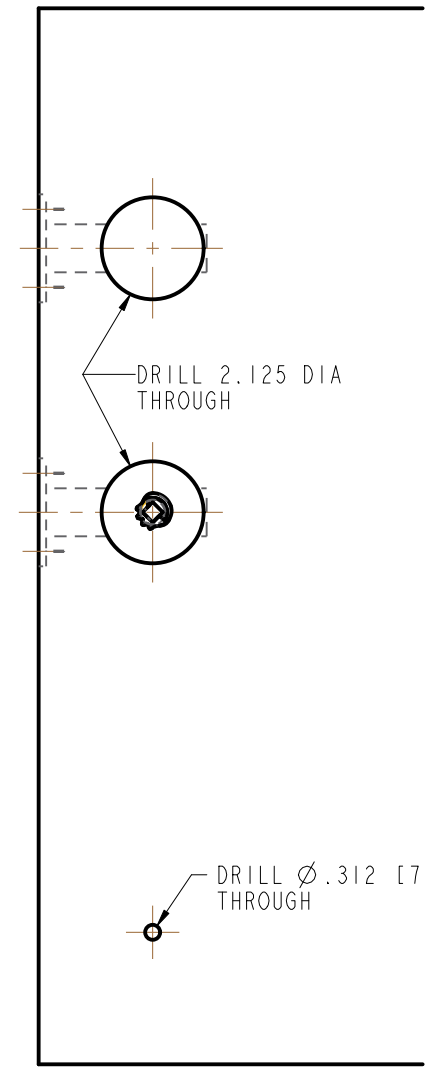

OUTSIDE

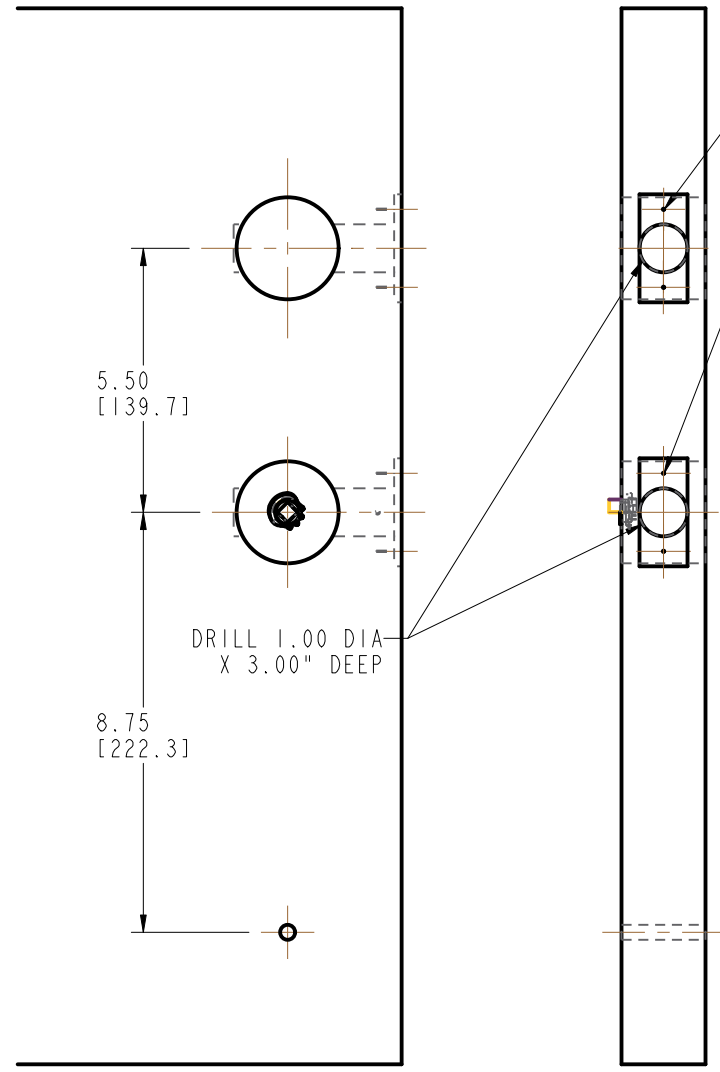
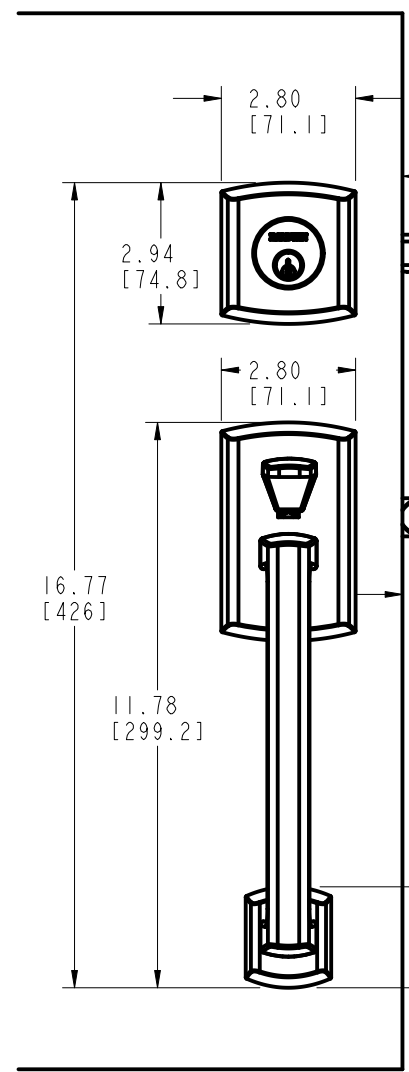

TRIM DETAIL  
RIGHT HAND ILLUSTRATED

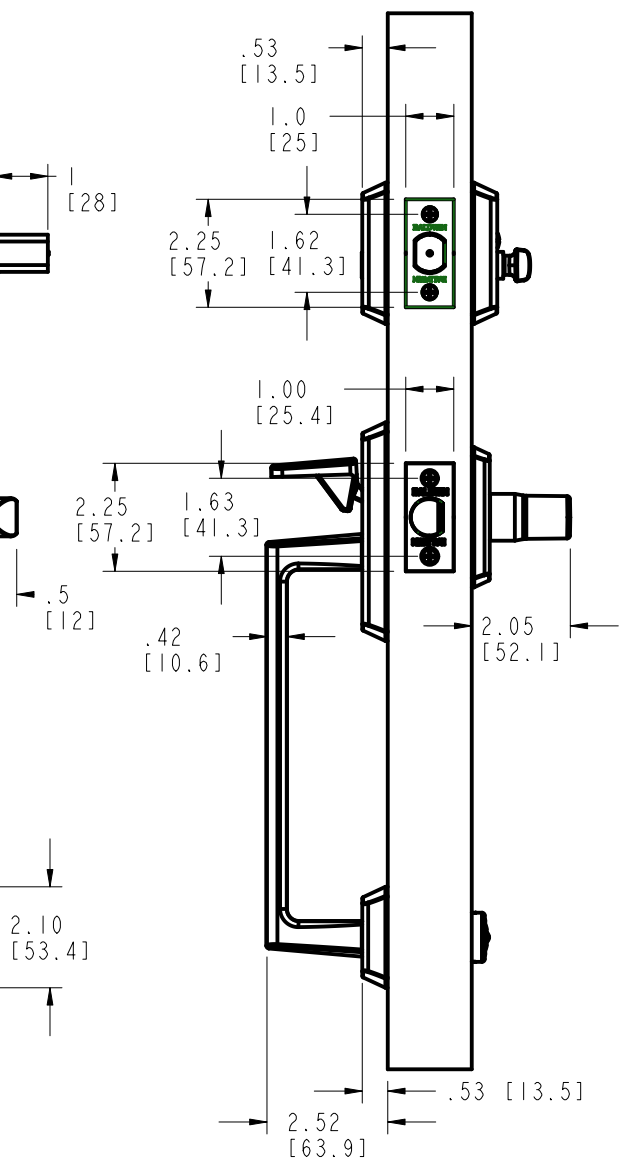

INSIDE

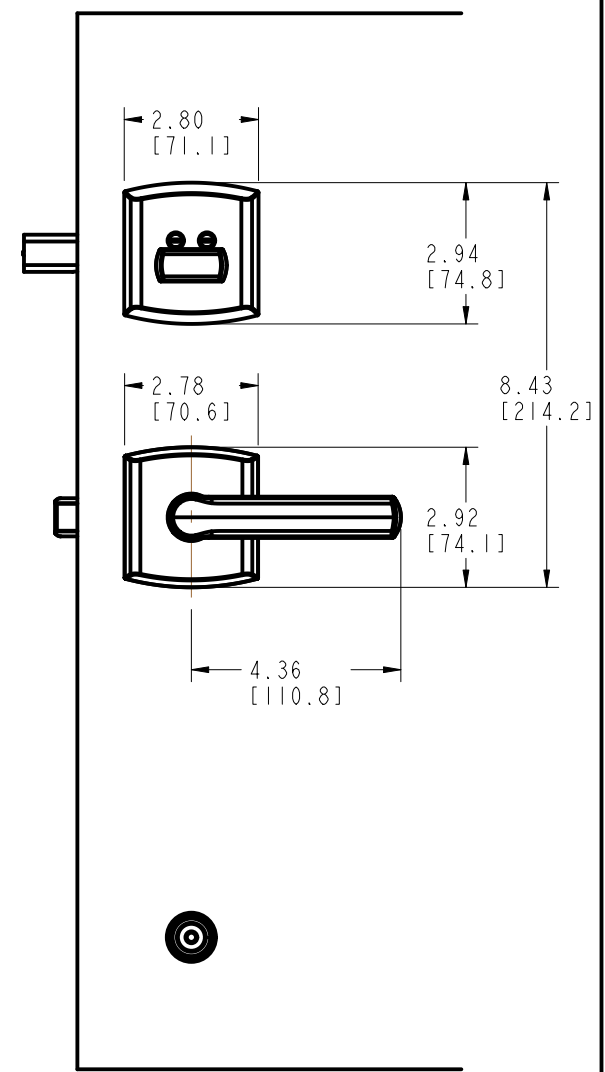

OUTSIDE

INSIDE

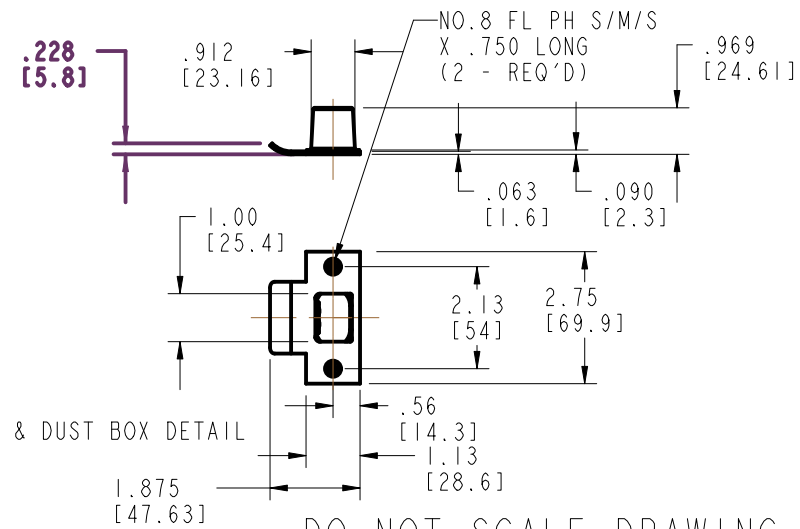
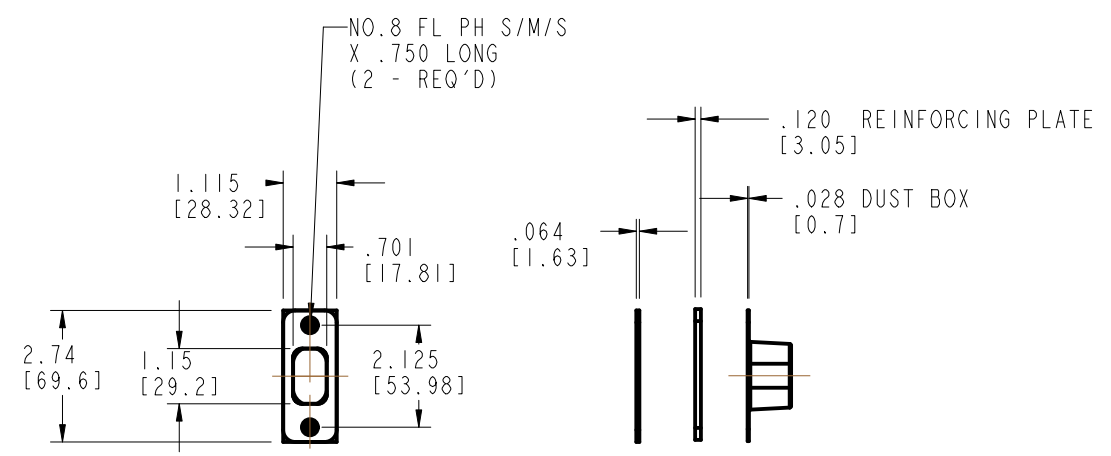

LATCH STRIKE & DUST BOX DETAIL

DO NOT SCALE DRAWING

EFFECTIVE: 05/12/2008

DEADBOLT STRIKE, REINFORCEMENT PLATE & DUST BOX DETAIL

**BALDWIN** A BLACK & DECKER COMPANY  
HARDWARE CORPORATION  
READING, PENNSYLVANIA

85386 SOHO TRIM

TEMPLATE: NO VARIATIONS

TEMPLATE NO.

© 2006 BY BALDWIN HARDWARE CORPORATION

IM386