

DOOR DETAIL

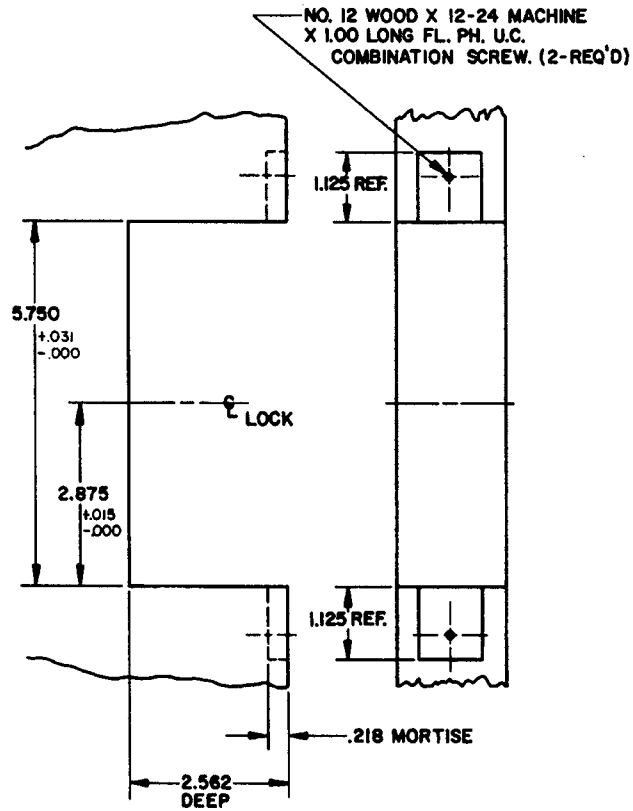

LOCK DETAIL

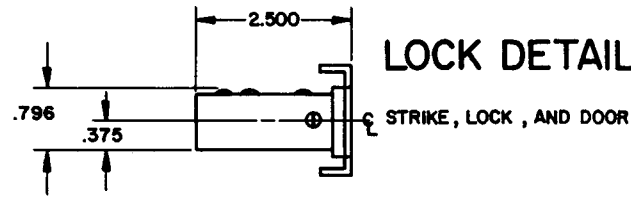

STRIKE DETAIL

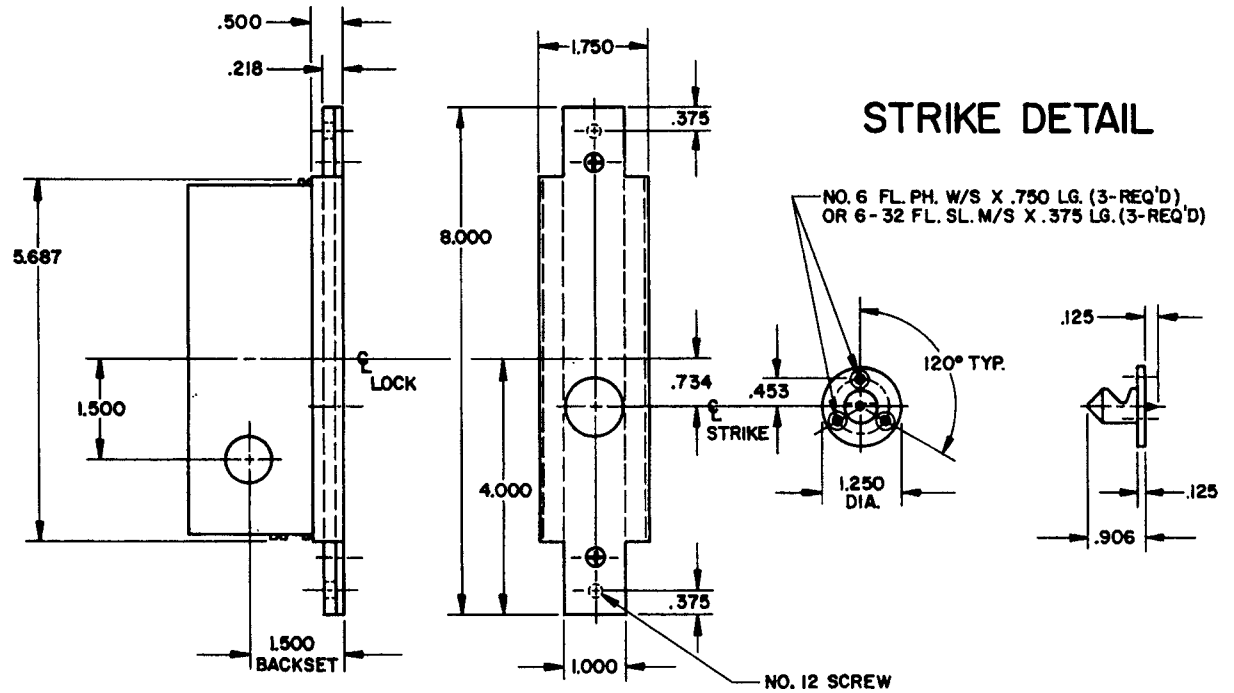

NOTE:

- 1.) SEE SPECIFIC TRIM TEMPLATE FOR ADDITIONAL DOOR CUTOUT DETAILS.
- 2.) THIS LOCK IS TO BE USED ON 1.750 THICK DOORS ONLY.

BALDWIN	
8575 LOCK (PASS)	
TEMPLATE NO. VARIATIONS	TEMPLATE NO
	J047

EFFECTIVE: 5-1-88

DO NOT SCALE DRAWING

© 1988 by Baldwin Hardware Corporation