

DOOR DETAIL

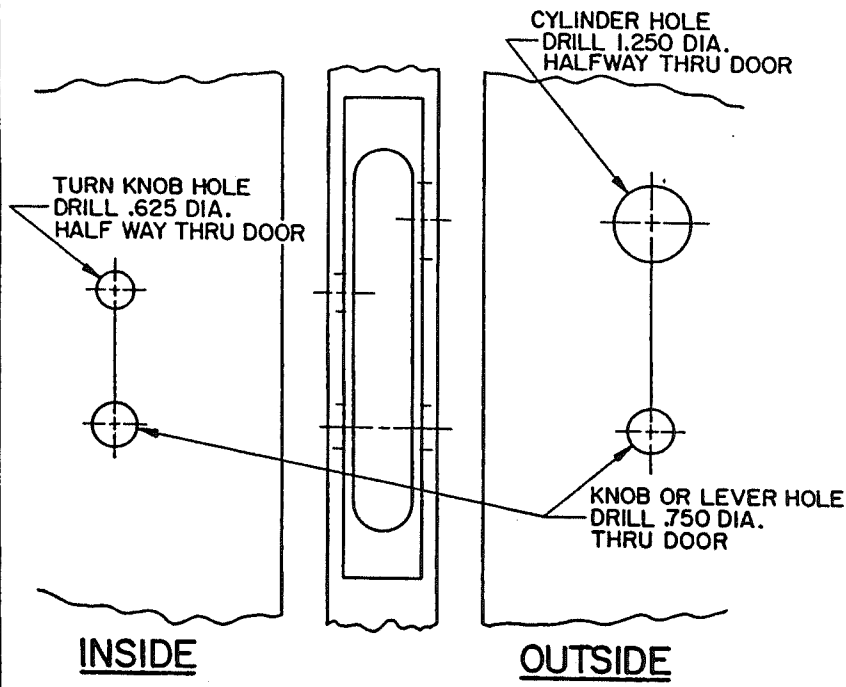

TYPICAL TRIM DETAIL

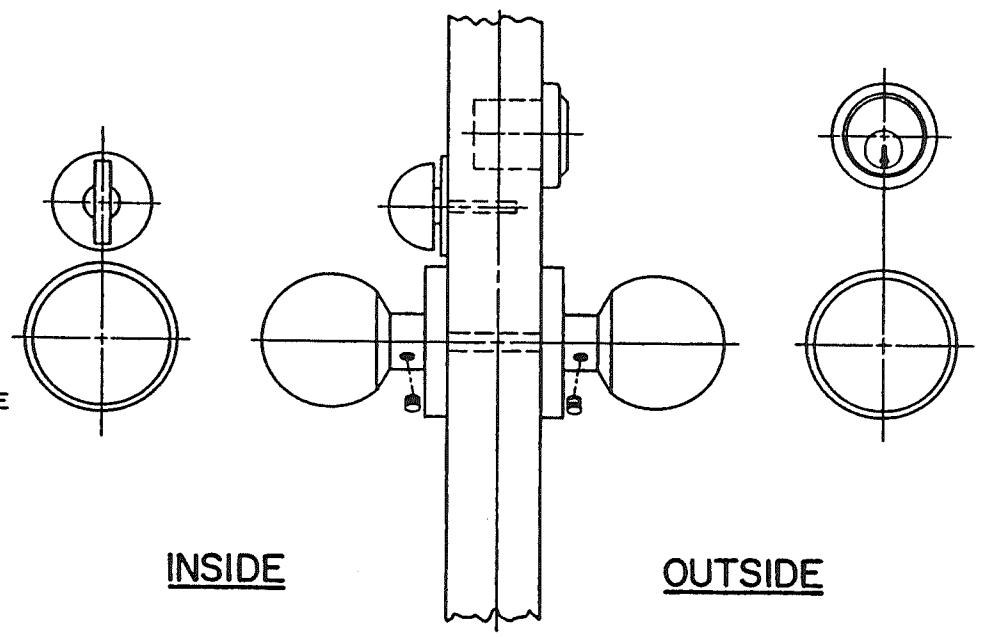

NOTE:

- 1.) FOR ADDITIONAL LOCK AND DOOR CUTOUT DIMENSIONS, SEE APPROPRIATE LOCK AND TRIM TEMPLATES.
- 2.) THIS TEMPLATE IS TEMPORARY ISSUE. TRIM PICTURED IS FOR ILLUSTRATION PURPOSES.

DO NOT SCALE DRAWING

B. BALDWIN	
ENTR FUNCTION	
TEMPLATE NO. VARIATIONS	TEMPLATE NO.
	F-ENT A