

### 30 Days Limited Warranty

The Coleman Company, Inc. warrants that for a period of 30 days from the date of original retail purchase, this product will be free from defects in material and workmanship. Coleman, at its option, will repair or replace this product or any component of the product found to be defective during the warranty period. Replacement will be made with a new or remanufactured product or component. If the product is no longer available, replacement may be made with a similar product of equal or greater value. This is your exclusive warranty.

This warranty is valid for the original retail purchaser from the date of initial retail purchase and is not transferable. Keep the original sales receipt. Proof of purchase is required to obtain warranty performance. Coleman dealers, service centers, or retail stores selling Sevylor® products do not have the right to alter, modify or in any way change the terms and conditions of this warranty.

#### What This Warranty Does Not Cover

This warranty does not cover normal wear of parts, parts that are not genuine manufacturer's parts, or damage resulting from any of the following: negligent use or misuse of the product; commercial use of the product; use contrary to the operating instructions; disassembly, repair or alteration by anyone other than Coleman or authorized service centers. Further, the warranty does not cover Acts of God, such as fire, flood, hurricanes and tornadoes. Warranty void if damage to product results from the use of a part other than a genuine Sevylor® part.

COLEMAN SHALL NOT BE LIABLE FOR DEFECTS THAT ARE CAUSED BY THE USE OF UNAUTHORIZED PARTS OR SERVICE. COLEMAN SHALL NOT BE LIABLE FOR ANY INCIDENTAL OR CONSEQUENTIAL DAMAGES CAUSED BY THE BREACH OF ANY EXPRESS OR IMPLIED WARRANTY OR CONDITIONS. EXCEPT TO THE EXTENT PROHIBITED BY APPLICABLE LAW, ANY IMPLIED WARRANTY OF MERCHANTABILITY OR FITNESS FOR A PARTICULAR PURPOSE IS LIMITED IN DURATION TO THE DURATION OF THE ABOVE WARRANTY OR CONDITIONS. SOME STATES, PROVINCES, OR JURISDICTIONS DO NOT ALLOW THE EXCLUSION OR LIMITATION OF INCIDENTAL OR CONSEQUENTIAL DAMAGES OR LIMITATIONS ON HOW LONG AN IMPLIED WARRANTY LASTS, SO THE ABOVE LIMITATIONS OR EXCLUSION MAY NOT APPLY TO YOU. THIS WARRANTY GIVES YOU SPECIFIC LEGAL RIGHTS, AND YOU MAY ALSO HAVE OTHER RIGHTS THAT VARY FROM STATE TO STATE OR PROVINCE TO PROVINCE.

#### How to Obtain Warranty Service

Take the product to an authorized Coleman service center. You can find the nearest authorized Coleman service center by visiting [www.coleman.com](http://www.coleman.com) or calling 1-800-835-3278 or TDD 1-316-832-8707 in the United States or 1-800-387-6161 in Canada. If a service center is not conveniently located, attach to the product a tag that includes your name, address, daytime telephone number and description of the problem. **Include a copy of the original sales receipt. Carefully package the product and send either by courier or insured mail with shipping and insurance prepaid to:**

#### For products purchased in the United States:

The Coleman Company, Inc.  
3600 North Hydraulic  
Wichita, KS 67219

#### For products purchased in Canada:

Sunbeam Corporation (Canada) Limited  
DBA Jarden Consumer Solutions  
20B Hereford Street  
Brampton (ON) L6Y 0M1

The costs of transporting the product to Coleman or an authorized service center for warranty service is the responsibility of the purchaser.

**DO NOT RETURN THIS PRODUCT TO THE PLACE OF PURCHASE.**

If you have any questions regarding this warranty please call 1-800-835-3278 or TDD 1-316-832-8707 in the United States or 1-800-387-6161 in Canada..

© 2009 The Coleman Company, Inc. All rights reserved.

QuickPump™, Park 'N' Play™, Clutch™, and Double Lock™ are trademarks of The Coleman Company, Inc.

Sevylor® is a registered trademark and  is a trademark of Sevca, LLC.



3600 North Hydraulic • Wichita, KS 67219 U.S.A.

1-800-835-3278 • [www.Sevylor.com](http://www.Sevylor.com)

4010005535 (20090914)



## INFLATABLE WATER RECREATION PRODUCTS

### IMPORTANT INFORMATION

- Open all valves before beginning inflation.
- Fill with cold air only.
- Adults should inflate the chambers.
- Do not let inflatable product come in contact with sharp, pointed objects.
- Never use compressors, CO<sub>2</sub>, or compressed air to inflate.
- **DO NOT OVER-INFLATE** – Inflate your product until most of the wrinkles in the material are gone & it feels firm to the touch.
- Be sure your product is completely dry before storing.

## ▲ WARNING

### READ THE FOLLOWING INSTRUCTIONS AND WARNINGS TO AVOID DROWNING OR SERIOUS INJURY

- NOT A LIFE SAVING DEVICE OR PERSONAL FLOTATION DEVICE.
- ALWAYS WEAR A U.S. COAST GUARD APPROVED TYPE III (PFD) VEST.
- NOT FOR USE BY CHILDREN WITHOUT ADULT SUPERVISION.
- PRODUCT IS DESIGNED FOR USE ON WATER ONLY.
- NEVER TOW FROM A BOAT OR ANY VEHICLE.
- NEVER ATTEMPT TO ATTACH A MOTOR.
- NEVER LEAVE IN OR NEAR WATER WHEN NOT IN USE.
- KNOW AND FOLLOW LOCAL WATER SAFETY RULES AND REGULATIONS.
- DO NOT OVERLOAD.
- NEVER PUT ARMS OR LEGS THROUGH THE GAPS OF INFLATED CHAMBERS, OR WEDGE HANDS OR FEET BETWEEN THE INFLATED CHAMBERS. SERIOUS INJURY MAY OCCUR.
- NEVER ALLOW DIVING INTO OR FROM THESE PRODUCTS.
- USE ONLY IN WATER AWAY FROM DEBRIS AND OBSTRUCTIONS. DO NOT USE IN HIGH WIND, RAPID CURRENTS OR DANGEROUS TIDES. BE FAMILIAR WITH THE AREA YOU INTEND TO USE THE PRODUCT.
- NEVER USE THESE PRODUCTS UNDER THE INFLUENCE OF DRUGS OR ALCOHOL.
- FILL WITH COLD AIR ONLY. DO NOT OVER INFLATE OR USE HIGH PRESSURE AIR COMPRESSOR TO INFLATE. FOLLOW THE INFLATION SEQUENCE ON THE PRODUCT IF APPLICABLE).

**CAUTION:** Water temperature & weather do affect the air pressure in inflatable products. In cold weather your product will lose some pressure due to the fact that the air will contract. If this occurs, you may want to add a little air to improve your product's performance. However, in hot weather, the air will expand. You must let some air out to prevent your product from failing due to overpressure. You should avoid exposing your product to extreme temperatures (hot or cold).

### How to Use the Park 'N' Play™ Connector:

The Park 'N' Play™ connector allows you to connect Sevylor® Water Recreation products together. All Sevylor® Water Recreation products can be connected together using this feature.

Replacement Part #5995-015

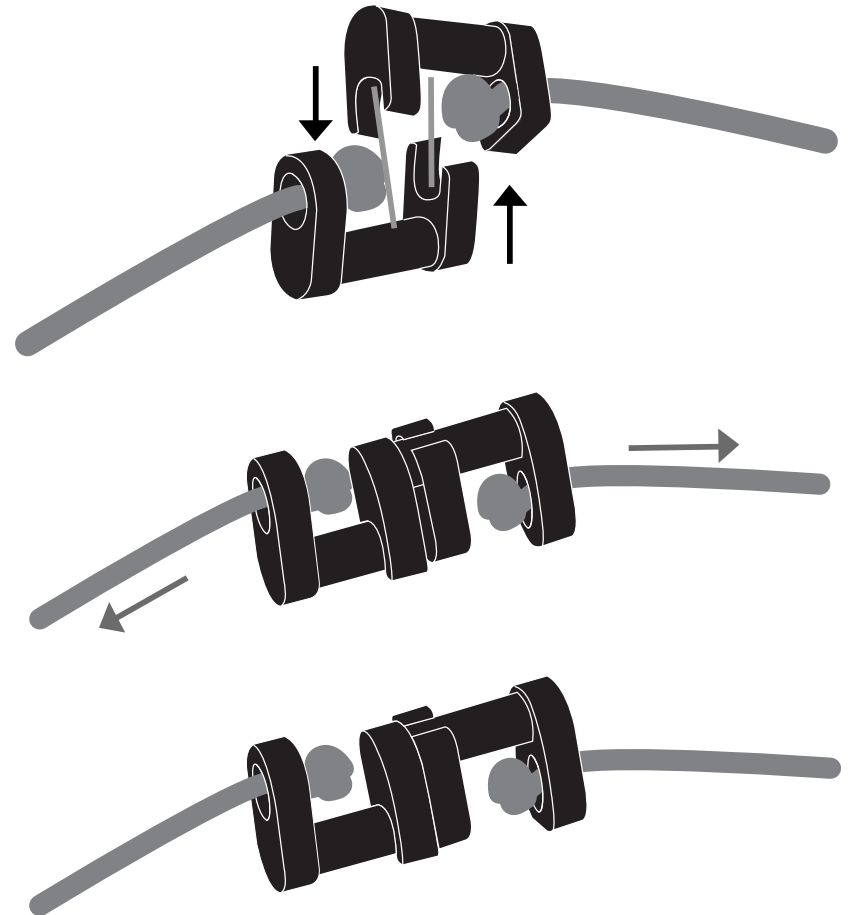

## Mothership with Clutch™ CONFIGURATION

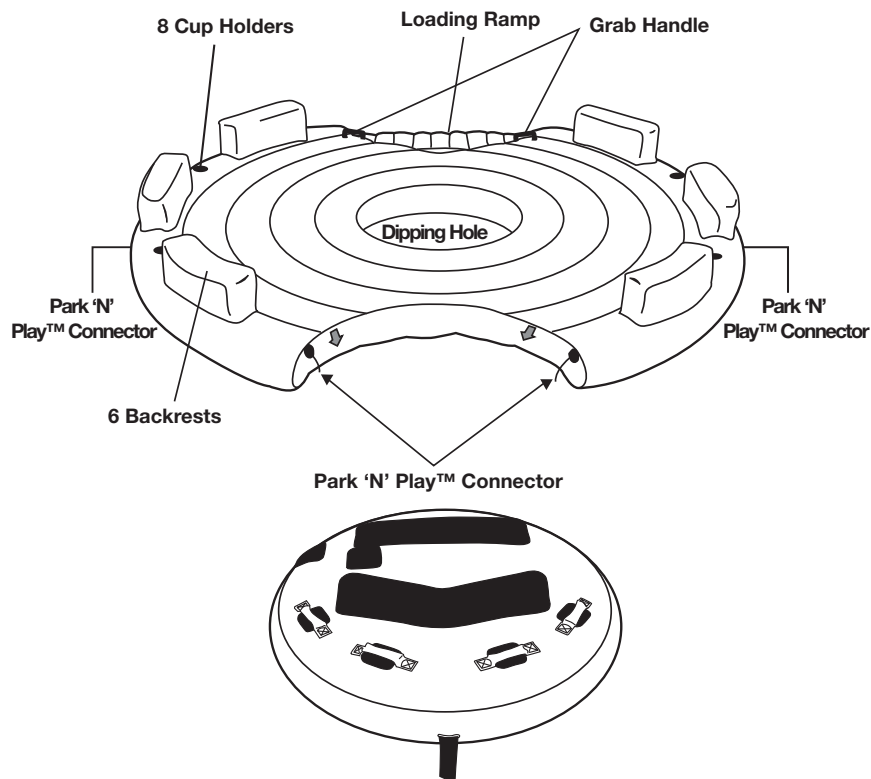

Clutch™ towable docks with Mothership Island

## CARE & STORAGE:

- Your product is made of the highest quality materials.
- Altering the construction of your product will void the limited warranty & could jeopardize the safety of the occupant.
- If the product has been used in salt water, rinse it off with fresh water as soon as possible.
- Remove tar spots or other soiled areas by using a mild soap & rinsing with fresh water.
- The product may be stored inflated, but do not place any heavy or sharp objects on or near it.
- Storage is best in a dry room.

## OPERATING INSTRUCTIONS:

- Familiarize yourself with current conditions where you plan to use your product. Use common sense and caution when operating in unfamiliar places.
- If your product has a specified weight limit, which will be located next to the inflation valve, do not overload past this limit. The safety of the occupant is jeopardized by over-loading.
- Be sure all accessories and/or equipment (for example, paddle, life jackets) are in proper working condition before using your product.
- Sharp objects are not to be carried in the product without adequate protection or storage.
- Watch for submerged or sharp objects that may damage or pierce the product.
- Never tow occupants in your product.

## INFLATION INSTRUCTIONS

To inflate using any Sevylor® QuickPump™ unit:

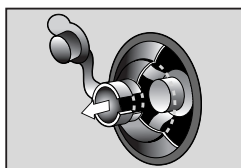

To begin inflation, open external stopper and pull to extend out.

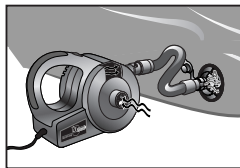

Attach adapter hose to inflation end of QuickPump™ unit. Insert hose and turn on.

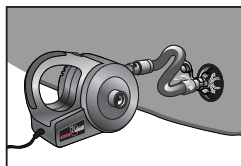

When fully inflated, seal valve by pushing in with hose nozzle to maintain seal. Gently twist adapter sleeve to right while backing adapter out of valve.



Fully remove adapter and close external stopper. Valve should appear depressed into itself.

To inflate using the Sevylor® Dual Action Hand Pump or other inflation device:

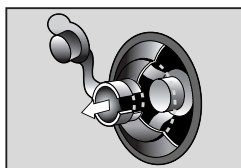

To begin inflation, open external stopper and pull to extend out.

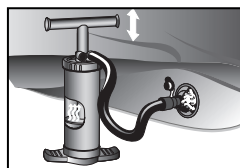

Insert nozzle of inflation device into the extended valve and turn on or begin pumping.

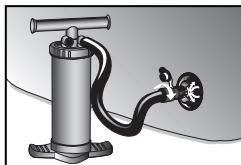

To close valve: Push in with inflation device until stopper has been depressed, sealing internal stopper.



Fully remove adapter and close external stopper. Valve should appear depressed into itself.

## DEFLATION INSTRUCTIONS

Deflation instructions using any Sevylor® QuickPump™ unit:

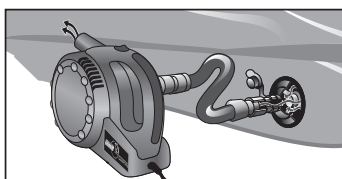

Remove adapter hose from inflation end and attach to opposite deflation end of pump. Repeat same steps as inflation. This will draw the air out quickly.

Deflation instructions using the Sevylor® Dual Action Hand Pump:

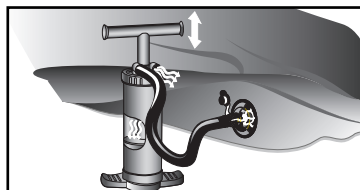

Remove adapter hose from inflation port and attach to deflation port on the base of the pump. Repeat same steps as inflation. This will draw the air out quickly.

## REPAIRING SMALL PUNCTURES

For inadvertent punctures, you can repair them with the included Sevylor® repair patch.

### INSTRUCTIONS:

1. Thoroughly clean and dry the damaged area. Completely deflate if an inflatable article.
2. Cut a portion of the patch to cover the puncture, and allow an additional ¼" on all sides. Always cut a round or oval patch. Never leave corners.
3. Be sure the spot is completely dry.
4. Peel the backing from the patch.
5. Adhere the patch to the puncture.
6. Using your thumb or finger apply even pressure across the entire surface of the patch.

The Sevylor® AirSeal repair kit is also another repair option available (Model # 2000003730 - not included). Sevylor® AirSeal is a fast, reliable repair for vinyl inflatables: air mattresses, toys, pools, boats as well as rainwear, groundsheets, golf bags, etc.

### INSTRUCTIONS:

1. Thoroughly clean and dry the damaged area. Completely deflate if an inflatable article.
2. When the damage is small (a pin hole or tear under 2 inches) apply a light coat of AirSeal two or three times. Allow five minutes to dry between each application.
3. For heavier material, e.g. fabric backed vinyl or a vinyl boat, apply up to five coats allowing a five-minute drying period between coats.
4. Ensure the AirSeal is completely dry before resuming use of the article.
5. When the damage is more extensive, cut a patch (with rounded corners) using any vinyl material. Generously coat the damaged area spreading the AirSeal at least 3/8" from the torn edges. Apply the patch and apply AirSeal to all edges of the patch making a seal between patch and the item being repaired. Allow the article to dry at least 10 hours before using.

Contains sufficient material for several small repairs. AirSeal is intended for use with 100% PVC (poly vinyl chloride) only.

**Do not use with any other material.**

You may purchase the Sevylor® repair patch (Model # 2000003731) and Sevylor® AirSeal (Model # 2000003730) by calling Coleman Customer Service at 1-800-835-3278 or going to [www.sevylor.com](http://www.sevylor.com).