

Assembly Instructions for SL35ST

IMPORTANT INFORMATION!

1. Remove collar, tags & leads from pet before placing it in the home to prevent possible entanglement.
2. Please save sales receipt as proof of purchase for warranty purposes.

Parts Identification

If you discover any parts are missing, immediately call our toll-free service helpline at 1-800-428-8560.

- (A) 1 - SL35ST Pet Home (B) 1 - Plastic Pan

Assembly Instructions

Drawings may vary from actual product

- 1** Remove the contents of the carton and place the Plastic Pan aside. Twist off the thin packing wires used to keep home together.
- 2** Expand the Pet Home into a rectangular form by gripping the top edges of the Side Panels and pulling the sides open. Make sure the four U-shaped legs are on the ground to insure the Pet Home is right side up.
- 3** Drop the Bottom Panel on the inside of the Pet Home and carefully connect the hooks to the bottom rung of the opposite Side Panel. The hooks are purposely made to fit snug so the bottom will be secure. It is important that the hooks be aligned with the hooks on the opposite side.
- 4** Flip the Top Panel over and carefully connect the hooks to the top rung of the opposite Side Panel. The hooks are purposely made to fit snug so the bottom will be secure. It is important that the hooks be aligned with the hooks on the opposite side.
- 5** Slightly lift up the front end of the top panel while pushing in on the top of the door panel so the wire catches in the hooks of the top panel. Repeat this step on the other end of the Pet Home.
- 6** Insert the plastic Bottom Pan by sliding the pan onto the floor of the Pet Home. Secure the Pan inside the Pet Home with the Pan Stop attached to the front of the bottom panel.

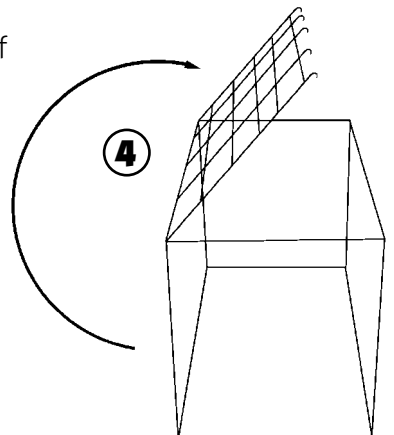
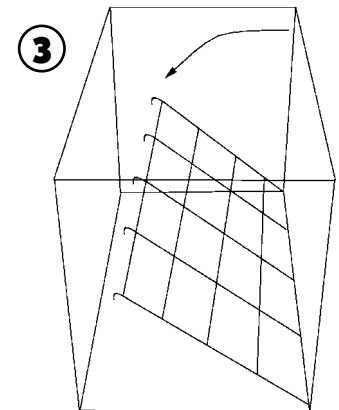
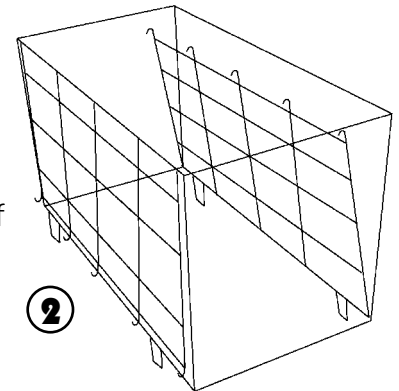

TOLL-FREE SERVICE HELPLINE:

If you have any problems or questions with the assembly, call our Service HELPLINE at **1-800-428-8560** between 9:00 am and 4:00 pm (EST) Monday - Friday.

NOTE: To protect the finish of your Pet Home and the bottom pan, use only mild, non-abrasive cleaners and water. Any coarse scrubbing or abrasive materials could damage the finish.

LIMITED MANUFACTURERS WARRANTY

1. For one (1) year from the date of original purchase, MIDWEST Homes For Pets ("MIDWEST") warrants to the purchaser of this pet home that, should it prove defective by reason of improper workmanship and/or material, MIDWEST will repair or replace, at its option, any defective part of the pet home, without charge for the part or for shipping. Replacement parts are warranted for the remainder of the original period.

2. **THIS WARRANTY DOES NOT COVER** defects in the wire enclosure caused by any animal, any physical abuse to or misuse of the pet home, any damage caused by the original purchaser or any third party, or any defects arising or discovered more than one (1) year from the original retail purchase date.

3. STEPS TO OBTAIN WARRANTY SERVICE:

A. The purchaser must call MIDWEST's HELPLINE, 800-428-8560, to report the alleged defect to a customer service representative or obtain missing parts.

B. The customer service representative will determine if the defect is covered by this warranty, and if it is, will authorize and instruct the purchaser in how to obtain corrective action.

C. MIDWEST may require the purchaser to present the sales receipt or other proof of purchase prior to authorizing any return or replacement. No returns or replacements will be permitted without proper authorization. If a return or replacement is authorized, you may be requested to return the item to MIDWEST or to make the item available for pick-up by MIDWEST.

4. **ANY EXPRESS WARRANTY NOT PROVIDED IN THIS WARRANTY DOCUMENT, AND ANY REMEDY FOR BREACH OF CONTRACT THAT, BUT FOR THIS PROVISION, MIGHT ARISE BY IMPLICATION OR OPERATION OF LAW, IS HEREBY EXCLUDED AND DISCLAIMED. THE IMPLIED WARRANTIES OF MERCHANTABILITY AND OF FITNESS FOR ANY PARTICULAR PURPOSE ARE EXPRESSLY LIMITED TO A TERM OF ONE (1) YEAR. SOME STATES DO NOT ALLOW LIMITATIONS ON HOW LONG AN IMPLIED WARRANTY LASTS, SO THE ABOVE LIMITATIONS MAY NOT APPLY TO YOU.**

5. **UNDER NO CIRCUMSTANCES SHALL MIDWEST BE LIABLE TO PURCHASER OR ANY OTHER PERSON OR ANY SPECIAL, INCIDENTAL OR CONSEQUENTIAL DAMAGES, WHETHER ARISING OUT OF BREACH OF WARRANTY, BREACH OF CONTRACT OR OTHERWISE, SOME STATES DO NOT ALLOW THE EXCLUSION OR LIMITATIONS OF INCIDENTAL OR CONSEQUENTIAL DAMAGES, SO THE ABOVE LIMITATIONS OR EXCLUSION MAY NOT APPLY TO YOU.**

6. This warranty gives you specific legal rights, and you may also have other rights which vary from state to state.



MidWest[®]
Homes For Pets
*America's Largest Home
Builder For Pets*