

Installation Support • Soporte de instalación • Support d'installation

**Personal Assistance, Product Specs, & "How-to" Questions:**

Asistencia personal, especificaciones del producto y preguntas sobre "cómo hacerlo":

Aide personnelle, spécifications du produit et questions « pratico-pratiques » :

**1-800-PFAUCET (732-8238)**  
**pfisterfaucets.com/support**

Installation Videos Available  
Videos de instalación a disposición  
Vidéos d'installation disponibles



[pfisterfaucets.com/videos](http://pfisterfaucets.com/videos)

**▲ WARNING / AVERTENCIA / AVERTISSEMENT**

To reduce the risk of injury or property damage, read all instructions before installing product. Wear safety goggles. Product must be installed in accordance with all state & local plumbing & building codes. Call a professional if you are uncertain about installing this product.

Para disminuir el riesgo de lesiones o daños a la propiedad, lea todas las instrucciones antes de instalar el producto. Utilice gafas de seguridad. El producto deberá instalarse de acuerdo con la normativa de plomería y construcción estatal y local. Llame a un profesional si no está seguro sobre cómo instalar este producto.

Pour réduire le risque de blessures ou de dommages, lire toutes les instructions avant d'installer l'appareil. Porter des lunettes de sécurité. Il faut installer l'appareil en respectant tous les codes de construction et de plomberie locaux et d'État. Appelez un professionnel si vous n'êtes pas certain de la façon d'installer cet appareil.

**Required Tools**  
Herramientas necesarias  
Outils nécessaires

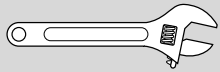

Adjustable Wrench  
Llave ajustable  
Clé réglable



Hex Wrench  
Llave hexagonal  
Clé hexagonale



Safety Goggles  
Anteojos de seguridad  
Lunettes de sûreté

**Additional Helpful Tools**  
Otras herramientas útiles  
Outils supplémentaires utiles

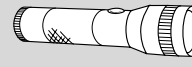

Flashlight  
Linterna  
Lampe-torche



Cloth  
Paño de limpieza  
Chiffon

**Parts in the Box**  
Piezas en la caja  
Pièces dans la boîte

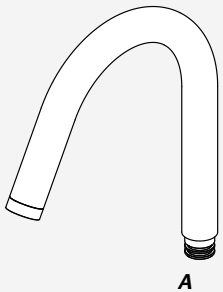

A

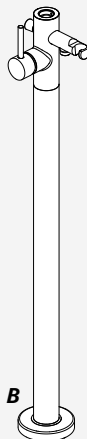

B



C

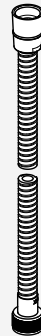

D

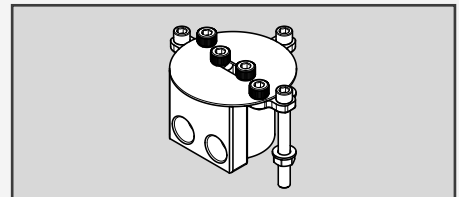

OX6-250 Valve sold separately  
OX6-250 Válvula se vende por separado  
OX6-250 Valve vendu séparément

**1 Turn Off Water Supply • Cierre el suministro de agua • Couper l'alimentation en eau**

Locate the water supply inlets & shut off the water supply valves. These are usually found near the water meter.

If you are replacing an existing unit, remove the old unit & clean mounting surface thoroughly.

Ubique las entradas del suministro de agua y cierre las válvulas de suministro. Estas se encuentran generalmente cerca del medidor de agua. Si reemplaza una unidad existente, retírela y limpie completamente la superficie de montaje.

Repérez les entrées d'alimentation d'eau et fermez les robinets d'arrêt. Ils sont normalement trouvés près du compteur d'eau. Si vous remplacez un appareil existant, enlevez le vieil appareil et nettoyez soigneusement la surface de montage.

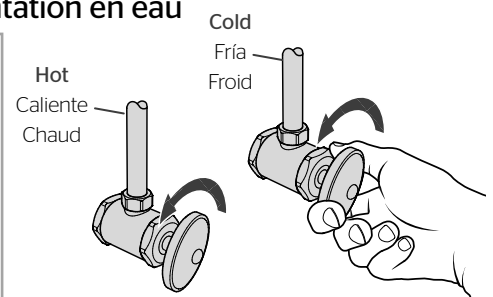

## 2 Spout Orientation

Prepare la tubería empotrada y configure la rotación del vástago

Préparez la plomberie brute et réglez la rotation

### Pick where Faucet will be installed

Recogida en donde se instalará el grifo

Choisissez où le robinet sera installé

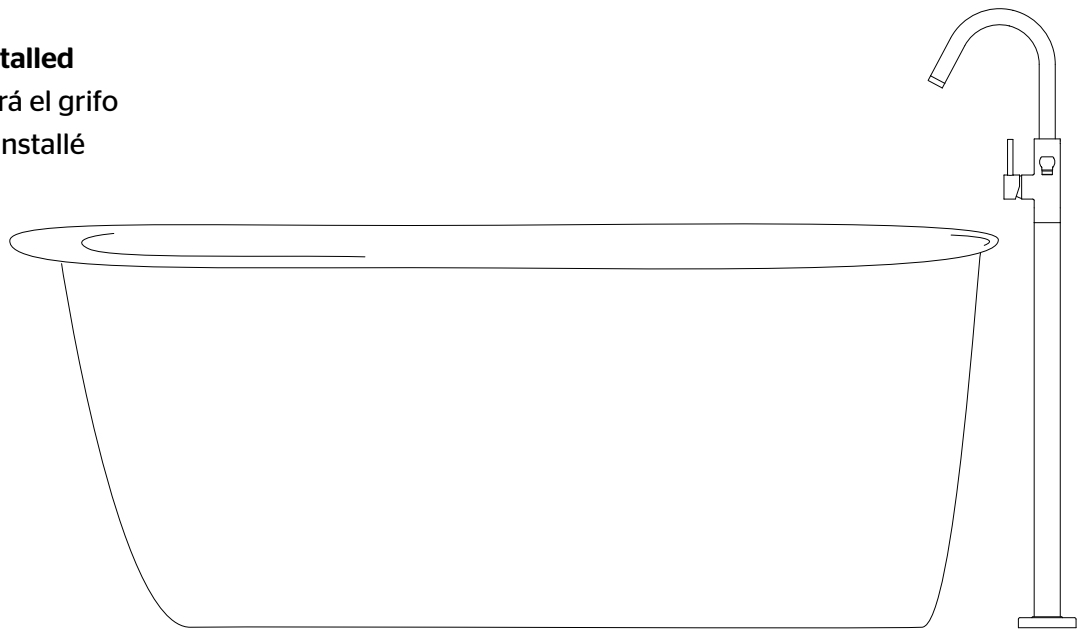

## 3 Prepare the Valve

Instale la Válvula

Installez la Soupape



Adjustable Wrench  
Llave ajustable  
Clé réglable

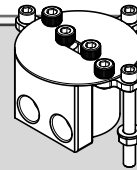

OX6-250 Valve sold separately  
OX6-250 Válvula se vende por separado  
OX6-250 Valve vendu séparément

3A

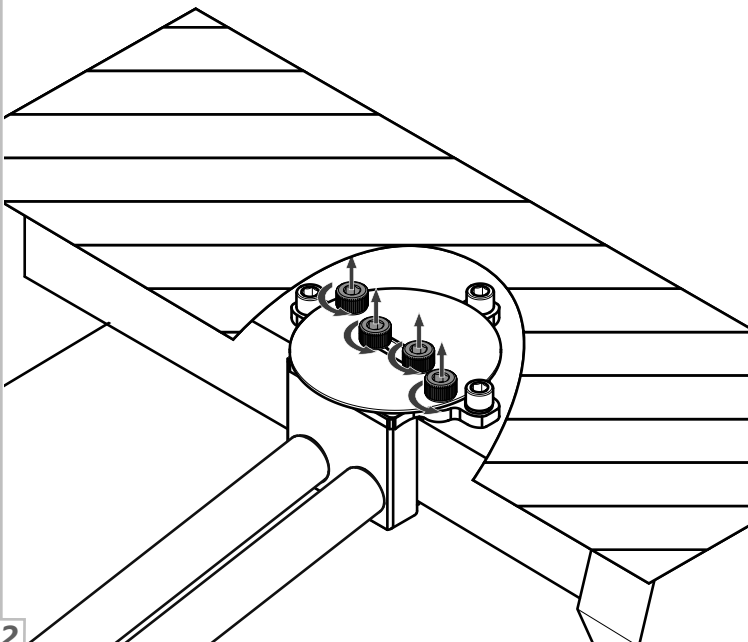

3B

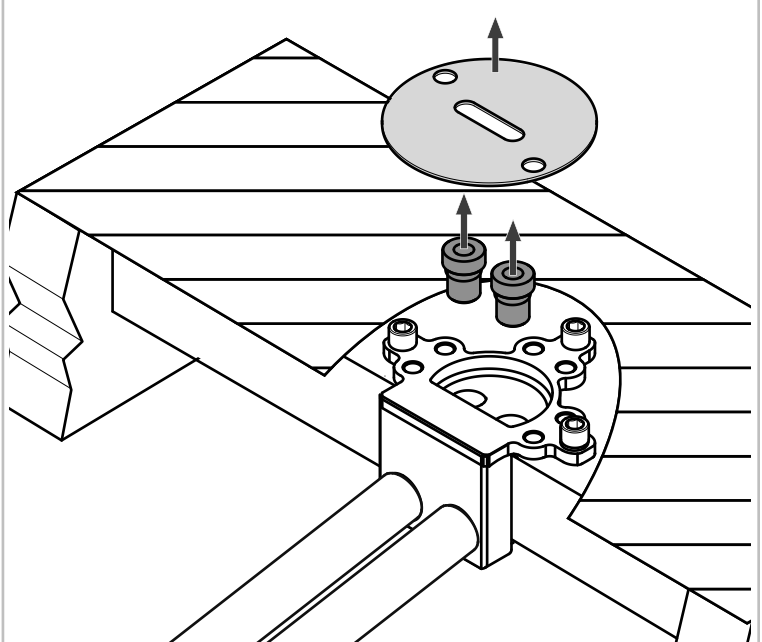

# 4

## Install Body

Instale el Cuerpo

Installez le corps

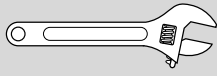

Adjustable Wrench  
Llave ajustable  
Clé réglable

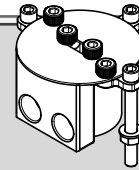
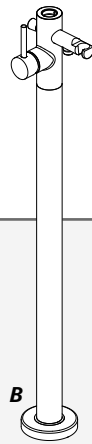

OX6-250 Valve sold separately  
OX6-250 Válvula se vende por separado  
OX6-250 Valve vendu séparément

### 4A

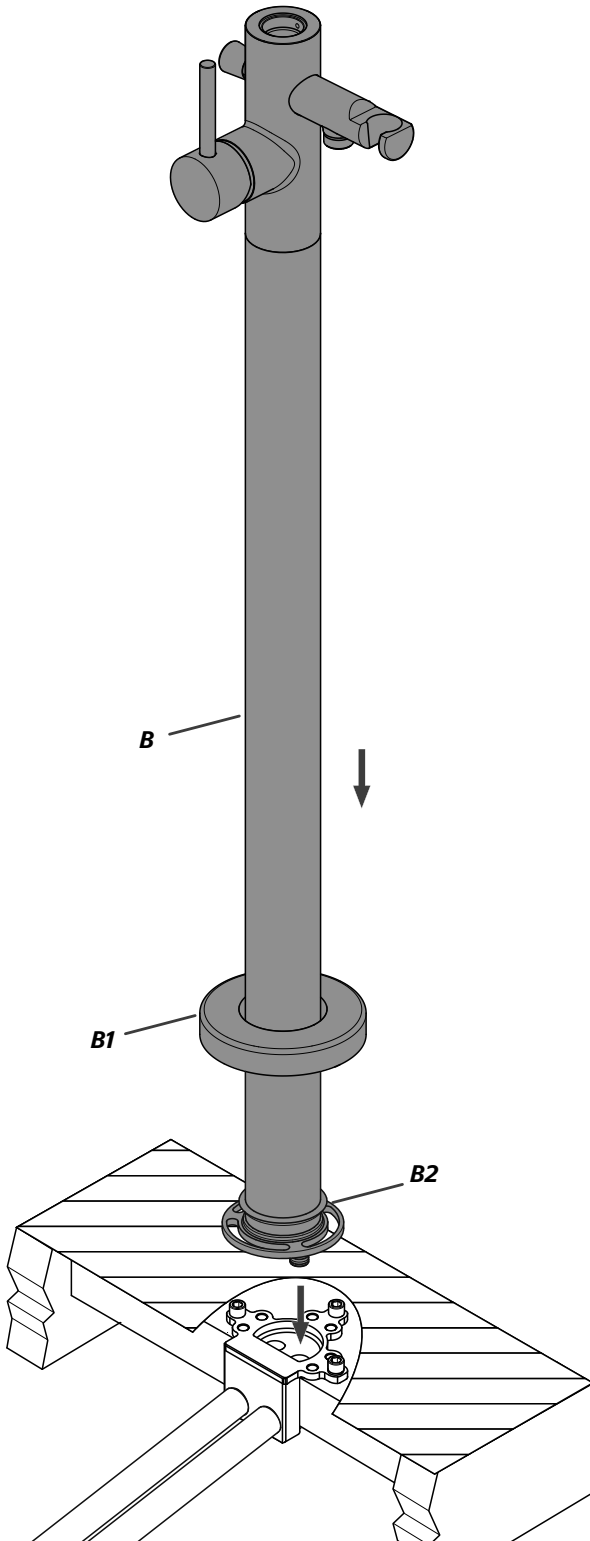

### 4B

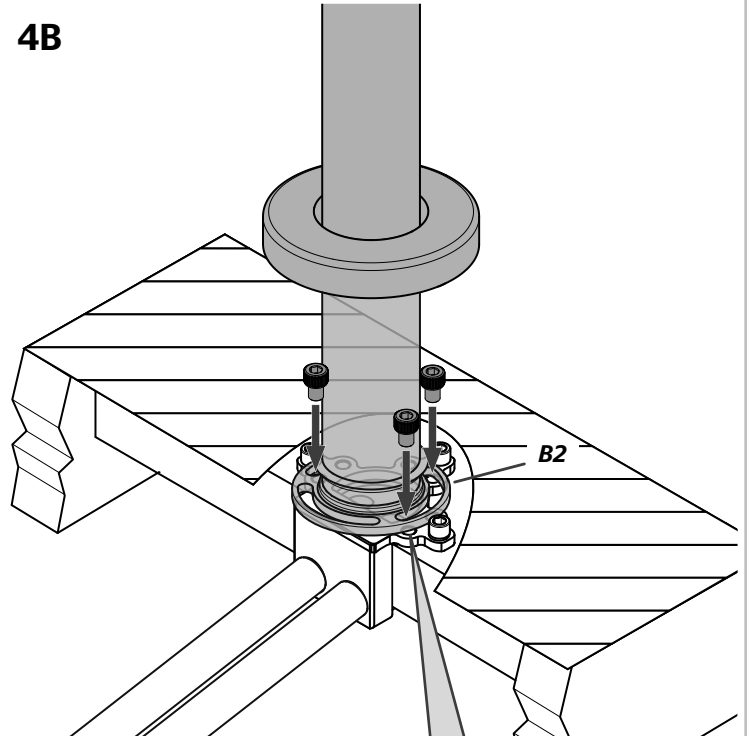

Insert Screws to 1 of 2 spots on the 3 prongs depending how flange (B2) aligned.  
Inserte los tornillos a 1 de 2 puntos en las 3 puntas dependiendo de cómo brida (B2) alinee.  
Insérer les vis 1 février points 3 points en fonction de la bride (B2) alignés.

### 4C

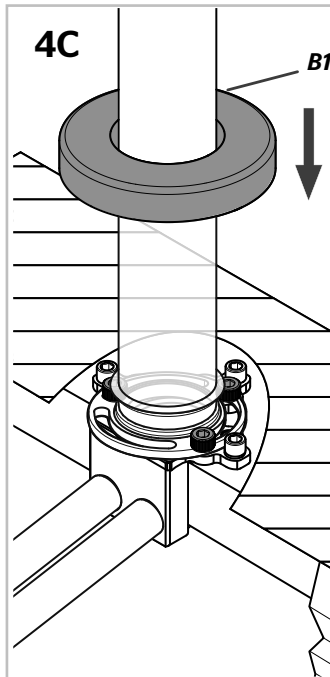

### 4D

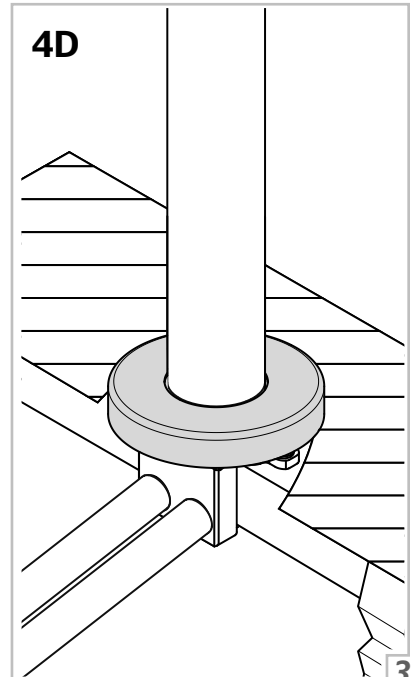

# 5

## Install Spout Instale el surtidor Installer le bec

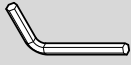

Hex Wrench  
Llave hexagonal  
Clé hexagonale

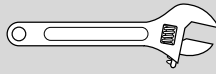

Adjustable Wrench  
Llave ajustable  
Clé réglable

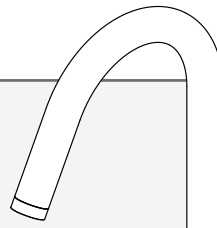

A

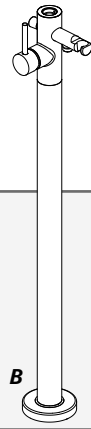

B

### 5A

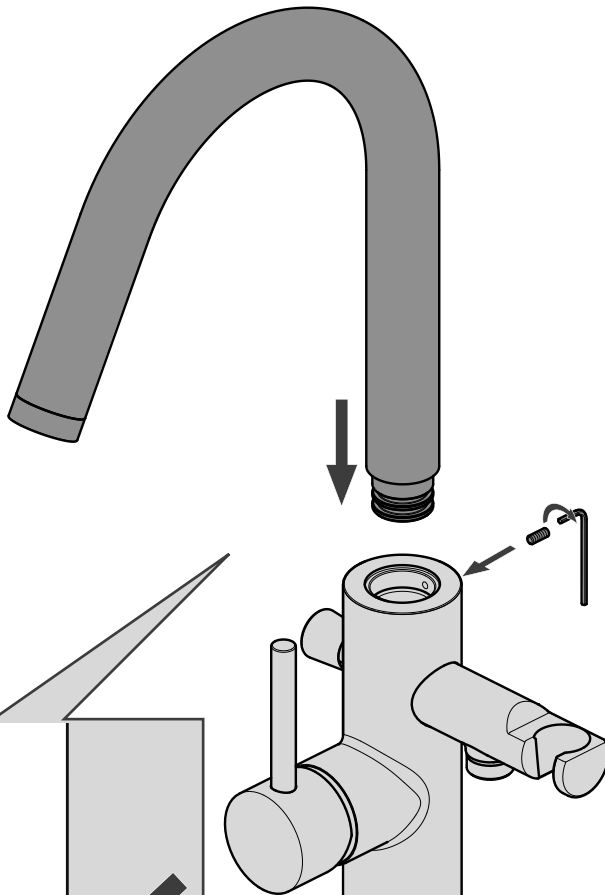

Align back  
Alinear detrás  
Aligner derrière

### 5B

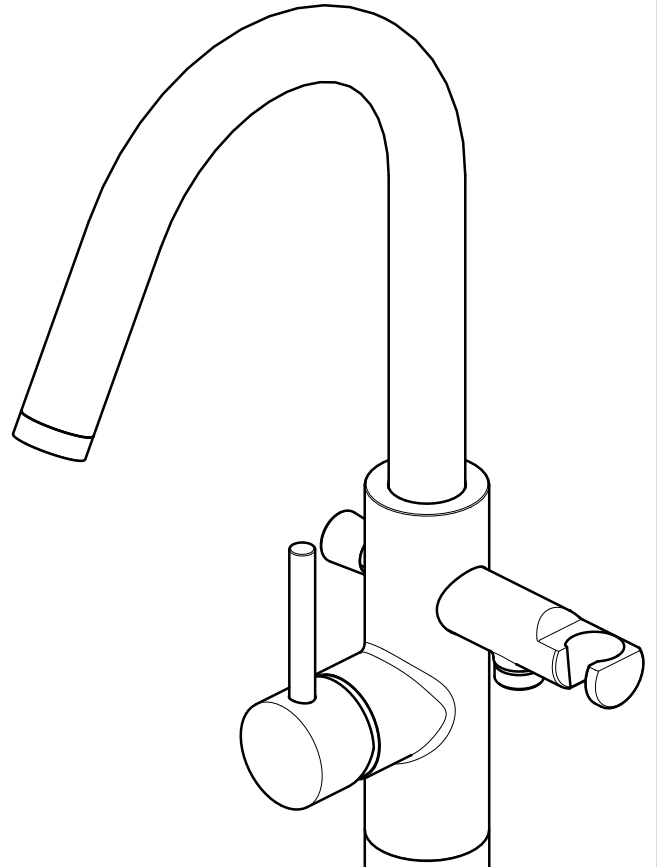

# 6

## Install Hand shower

Instale la ducha de mano

Installez la douchette

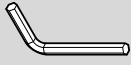

Hex Wrench  
Llave hexagonal  
Clé hexagonale

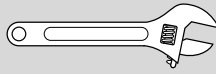

Adjustable Wrench  
Llave ajustable  
Clé réglable



C



D

6A

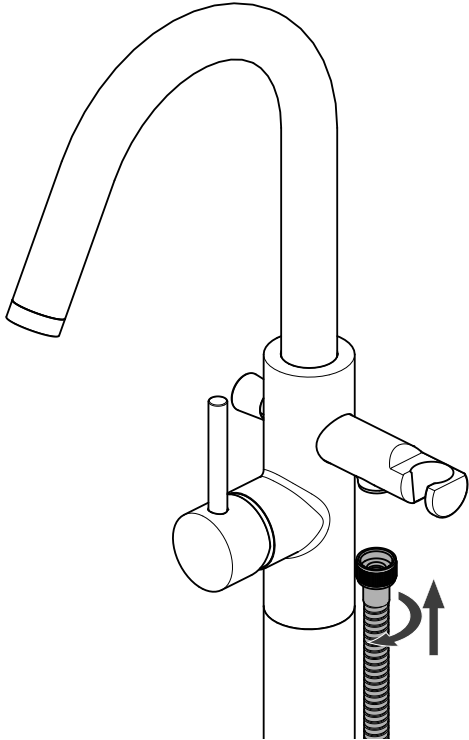

6C

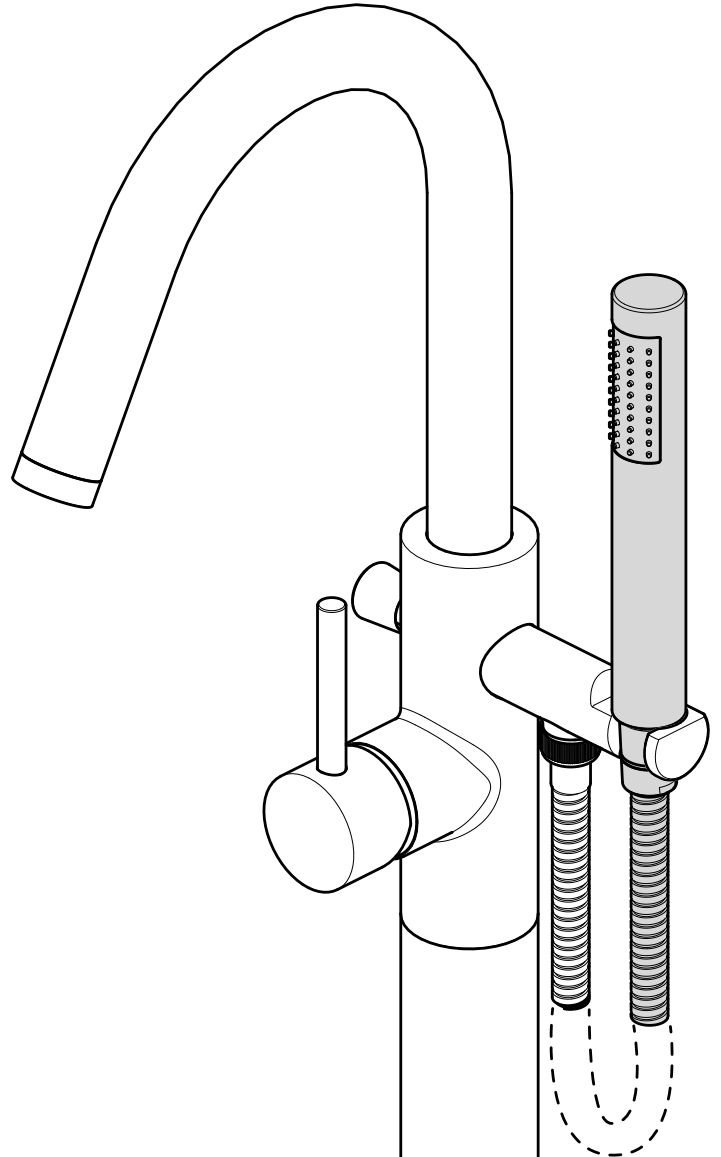

6B

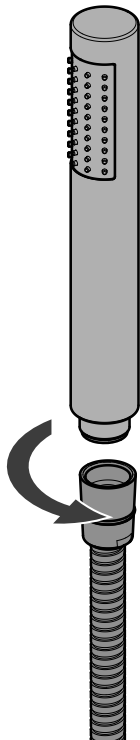

## 7 Turn On Water & Confirm Proper Installation

Active el suministro de agua y confirme que la instalación está adecuadamente efectuada  
Ouvrez l'eau et confirmez que l'installation est adéquate

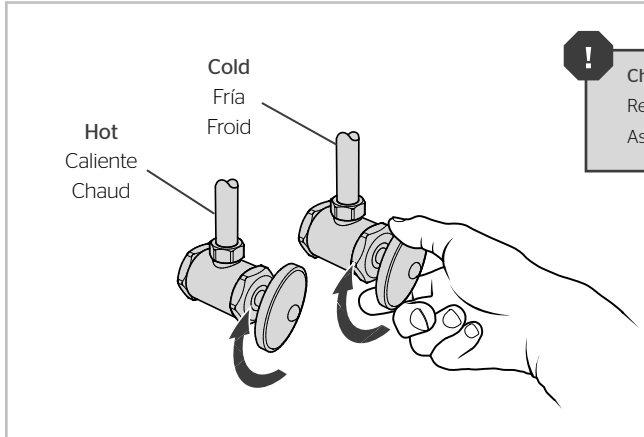

**!** Check for leaks above and below the sink.  
Revise si hay fugas encima y debajo del fregadero  
Assurez-vous qu'il n'y a pas de fuite au dessus ou au dessous du lavabo

## 8 Flush the Faucet

Enjuague el grifo  
Vidanger l'robinet

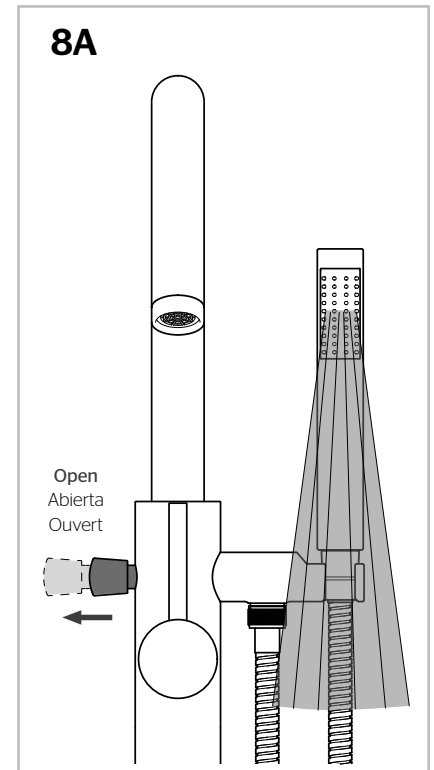
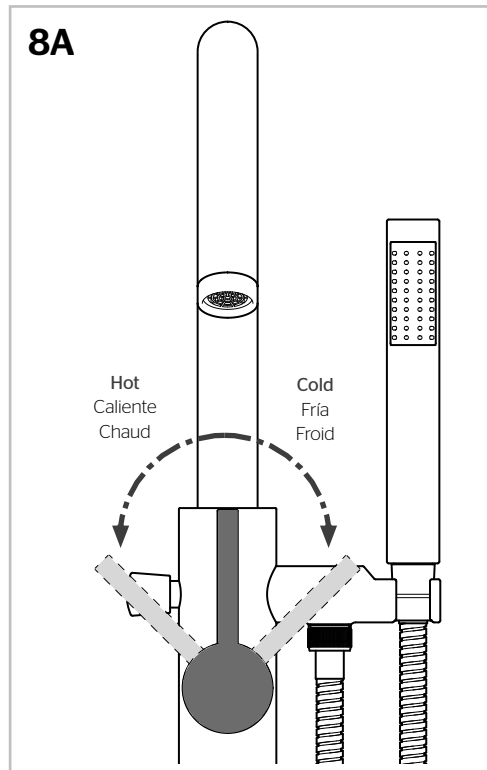
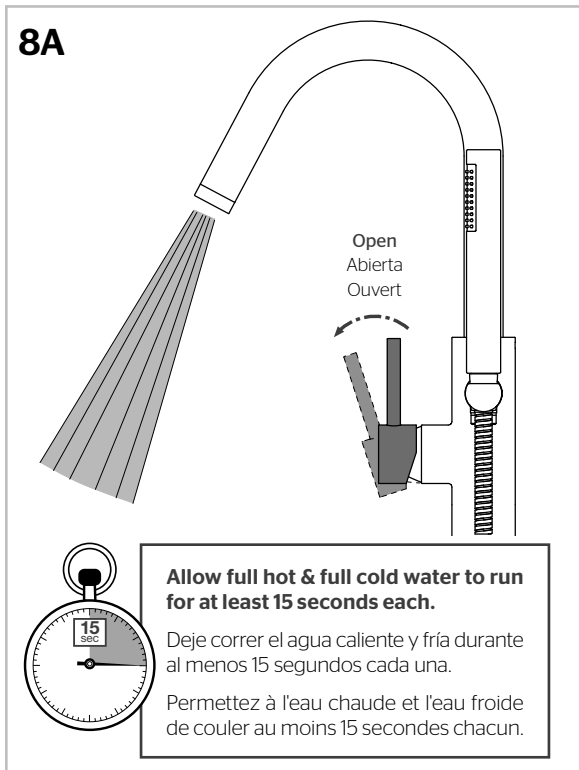

For Additional Installation Help:  
Para la instalación adicionales de ayuda:  
Pour aider à l'installation supplémentaires:

**Pfister**

1-800-PFAUCET (732-8238)  
pfisterfaucets.com