



# FARM & COMMERCIAL SLIDING DOOR SYSTEMS



2016 PRODUCT CATALOG



**3** TESTED TO BE  
**3X**  
CORROSION RESISTANT  
over standard ZINC

WeatherGuard™ protection greatly enhances the performance of standard zinc products, formulated to withstand the harshest weather conditions and stand up to the corrosive effects of pressure treated lumber. Extensive testing and field use have proven WeatherGuard is far superior in corrosion resistance over competitive standard zinc-plated products.

When subjected to 312 hours of salt fog spray testing (BHMA A156.18), standard zinc hardware showed severe corrosion while hardware protected by WeatherGuard withstood these harsh conditions with very little deterioration.

**Benefits of WeatherGuard™:**

- Superior corrosion protection for indoor & outdoor use
- Extends the life and aesthetics of steel hardware products
- Safe for use with pressure treated/ACQ lumber

For more information about WeatherGuard™ visit:  
[www.nationalweatherguard.com](http://www.nationalweatherguard.com)

# TABLE OF CONTENTS

## SLIDING DOOR APPLICATIONS

Typical Installations	5
Single	7
By-Passing	7
Accordion Fold	7
Planning Checklist	8

## SLIDING DOOR FRAMES

Tab-Loc™	9-11
Easy-Frame®	12,13
Sliding Door Frame Accessories	14-16
Max Easy-Frame	17-19
Sliding Door Frame Accessories	20
Aluminum	21-24

## BOX RAILS

Box Rail & Accessories	25-28
Box Hangers	29
Flexible Box Hangers	30
Rigid Box Hangers	31
Installations/Rails-Hanger Chart	32

## TRACKMASTER® ROUND RAIL & HANGERS

Benefits	34
Checklist	35
Round Rail & Brackets	36
Flashing	37
Round Hangers	38,39



# SLIDING DOOR APPLICATIONS



Aircraft Hanger



Horse Facility



Lumberyard



Livestock Facility

# TYPICAL INSTALLATIONS

## Tab-Loc™ / Max Easy-Frame®

### Steel Sliding Door Frame

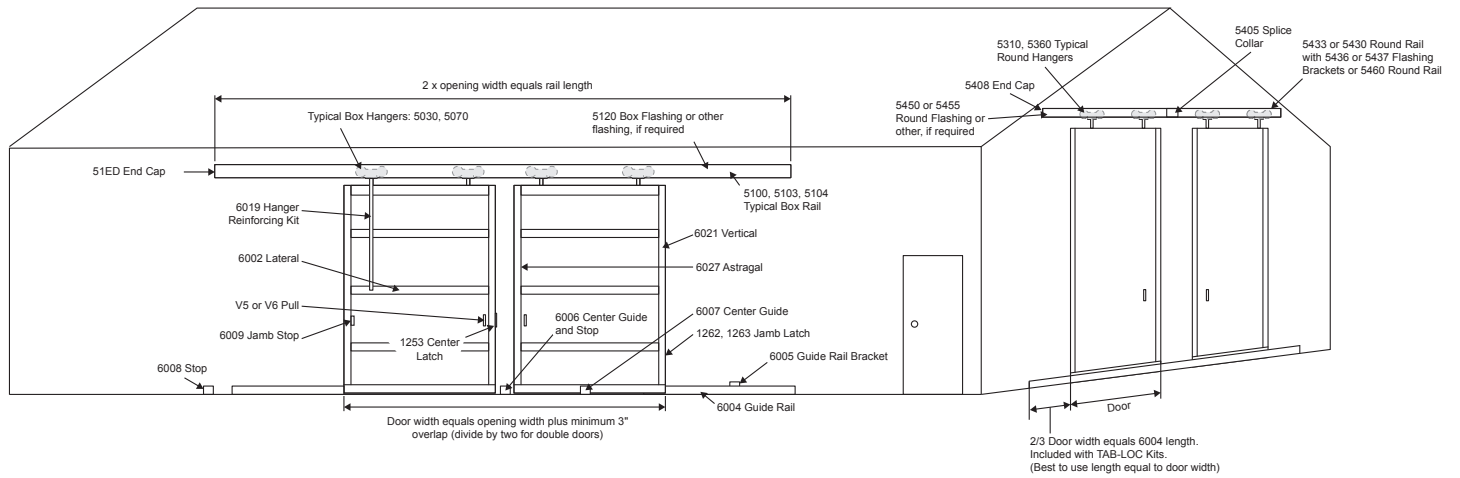

## Easy-Frame®

### Steel Verticals for 1-1/2" and 3-1/2" Wood Laterals

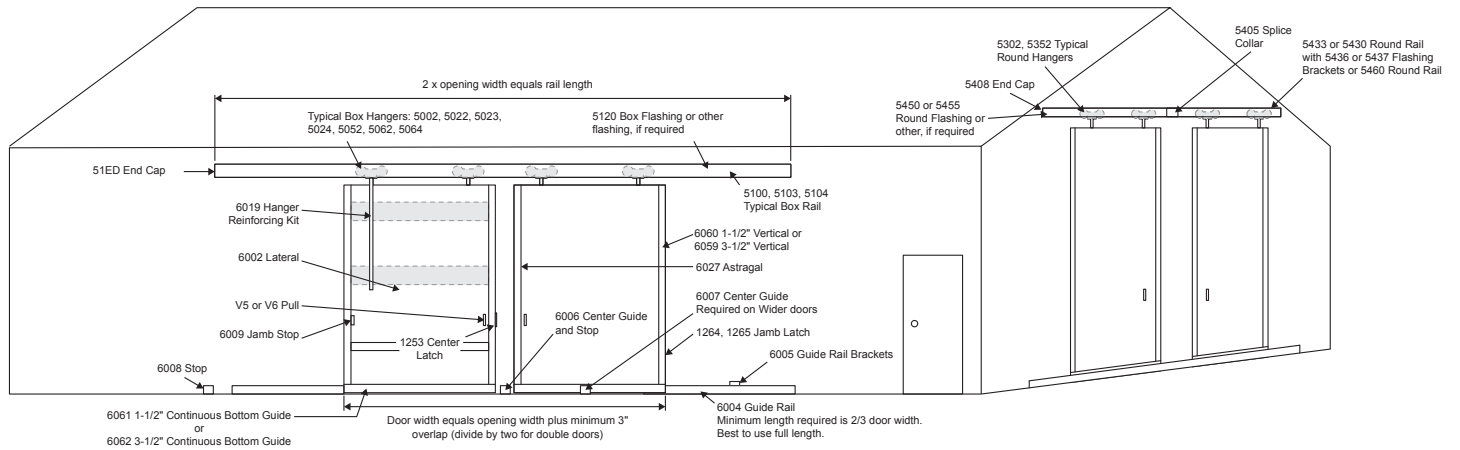

## Aluminum Door Frame

### 1-1/2" Wood Laterals

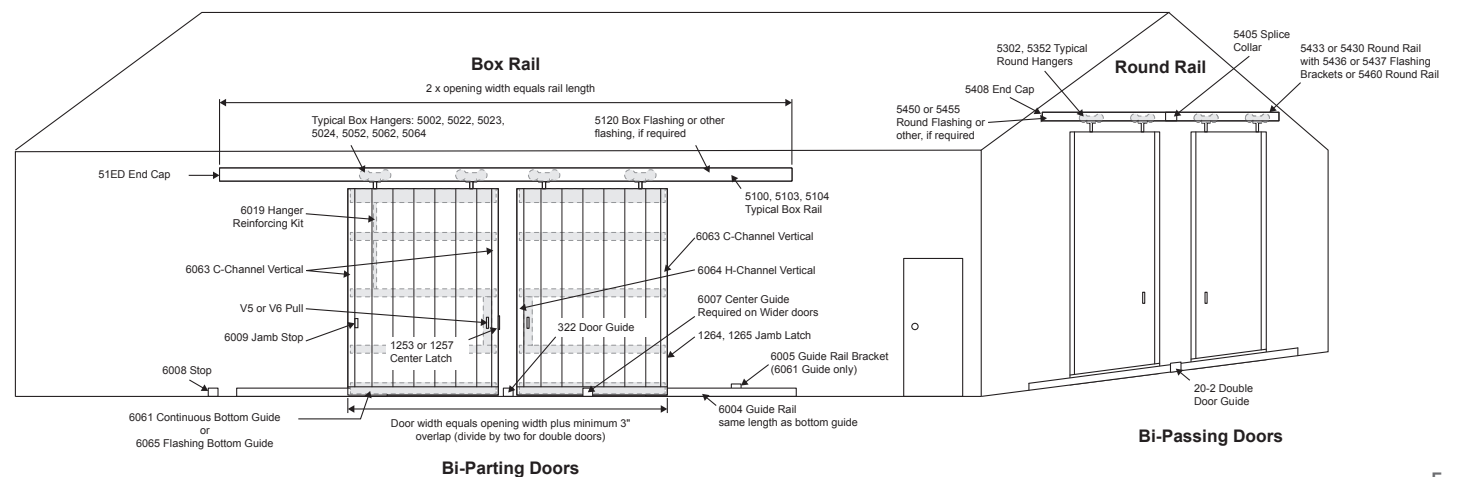

# TYPICAL INSTALLATIONS

## All Wood Frame Sliding Door

1-1/2" or 3-1/2" Thick With Metal Siding on Metal Sided Building

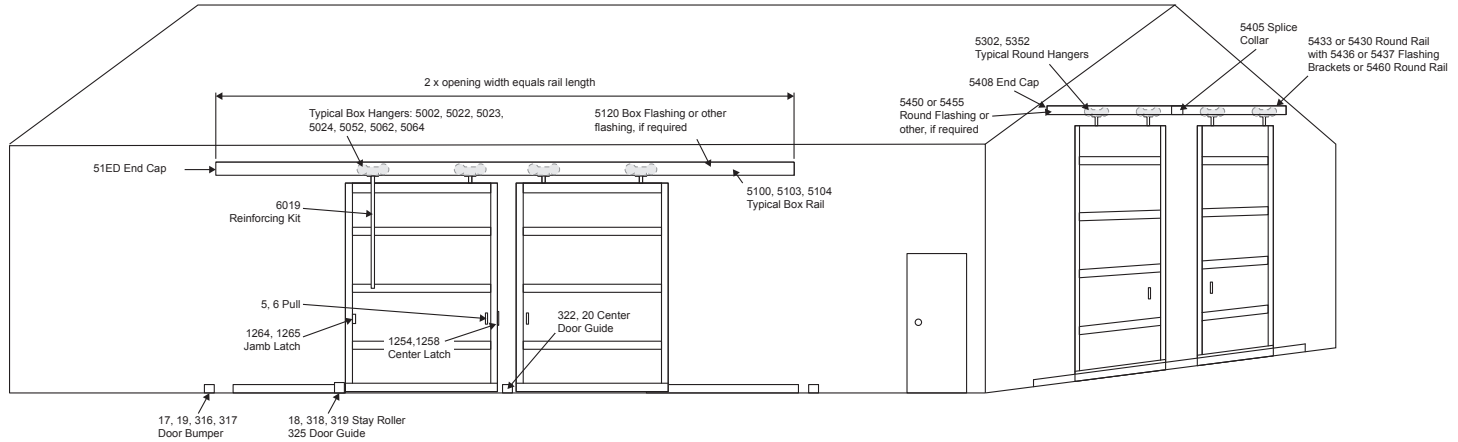

## All Wood Frame Sliding Doors (Less Than 1-1/2" Thick Frame)

Less Than 1-1/2" Thick Frame With Wood Siding on Wood Sided Building

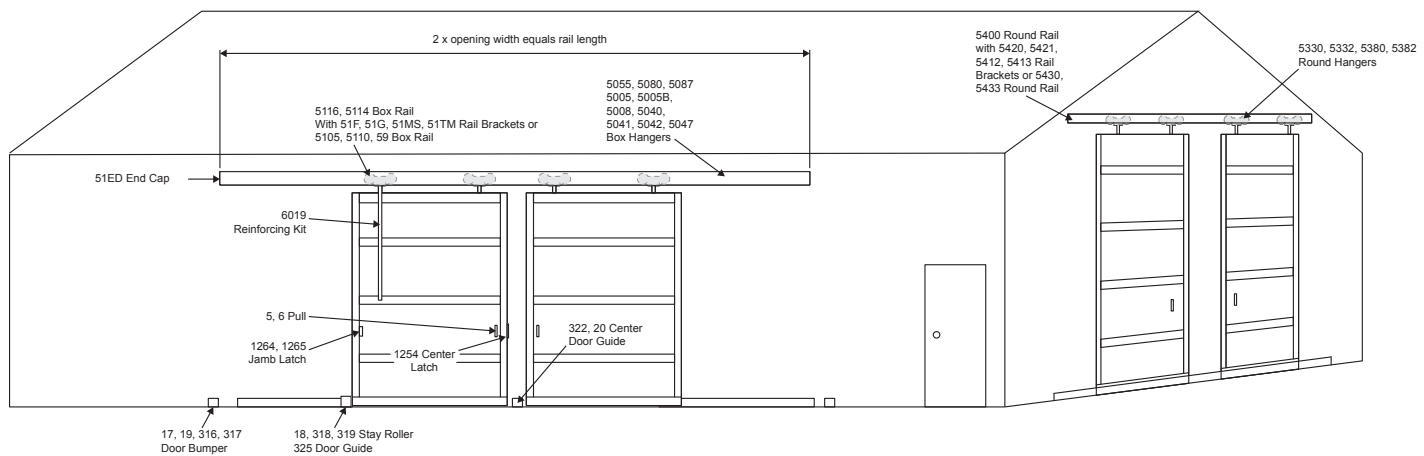

# TYPICAL INSTALLATIONS

## Single & Bi-Parting for Box & Round Rail

**Operation:** A single sliding door, or two sliding doors meeting at the center of the opening (bi-parting) allowing maximum doorway access to the building. This system requires a single run of rail approximately twice the width of the door opening running along the door side of the building to carry the door(s).

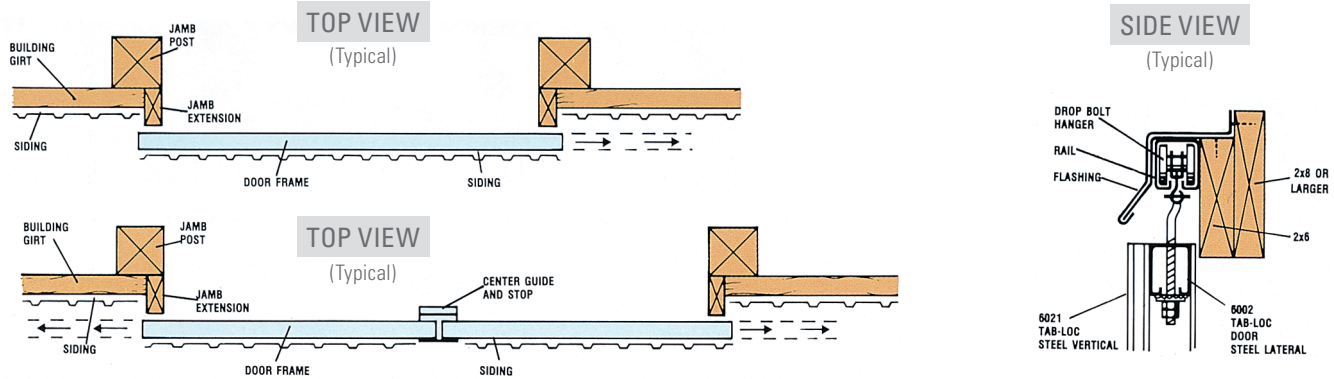

## By-Passing for Box & Round Rail

**Operation:** Two runs of rail carry two or more door panels. When open, the inner panel(s) store behind the outer panel(s). Triple brackets are also available for triple runs of rail.

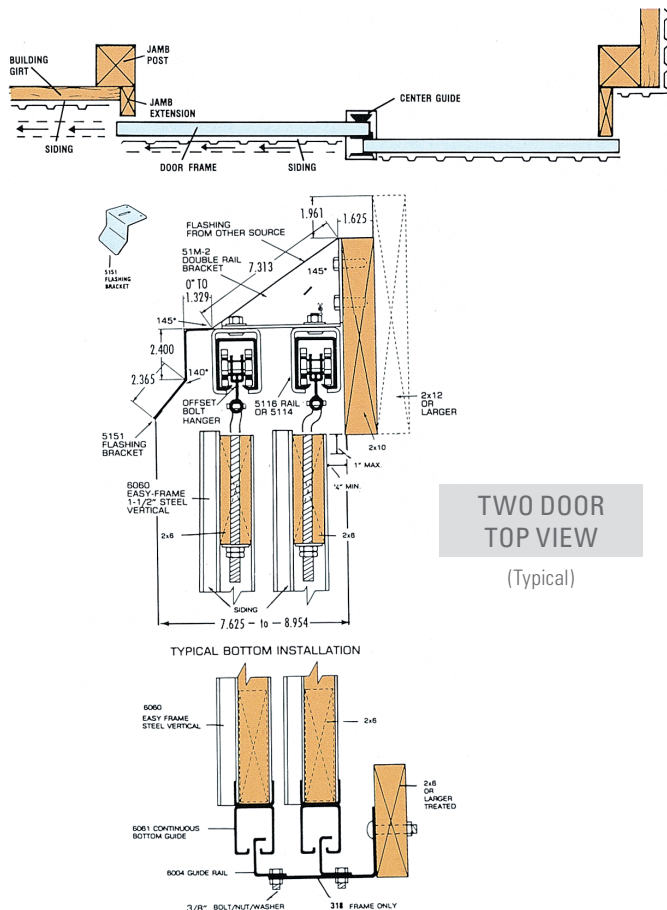

## Accordion

The Accordion system is used in churches, schools and auditoriums or wherever a number of doors are hung together in series in an opening. No. 47 hangers and 5116 or 5114 rail are used. The system can be suspended from the header with ceiling brackets, or the rail may be secured with tech screws drilled directly to the header.

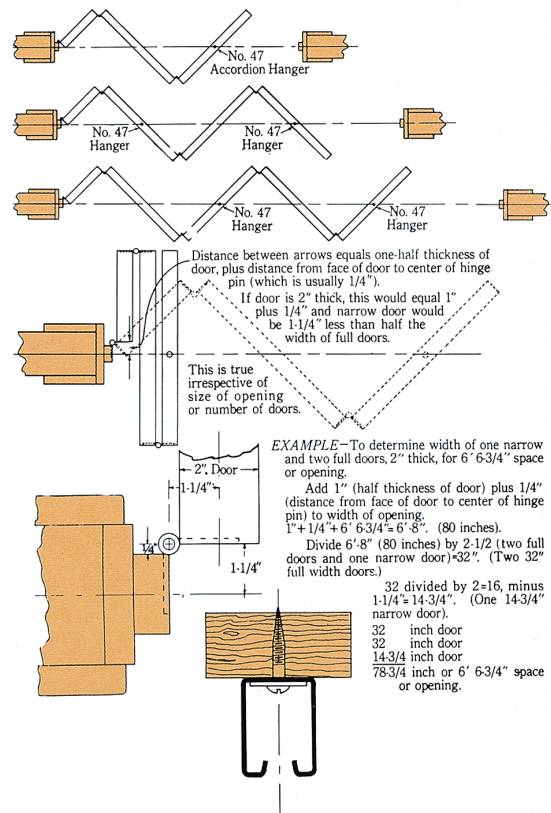

# SLIDING DOOR SYSTEMS PLANNER

## Single & Bi-Parting

- Box or Round Rail
- Rail Brackets (if needed)
- Rail Flashing (if needed)
- Hangers
- Door Bumpers/Stops
- Door Guides
  - Floor Mounted
  - Side Mounted
- Stay Rollers
- Jamb Latches
- Center Latch
- Door Pulls
- Door Frame Systems
  - Tab-Loc™
  - Easy-Frame®
  - Max Easy-Frame®
  - Aluminum

## By-Passing

- Box or Round Rail
- Double or Triple Rail Brackets
- 5151 Flashing Brackets
- Hangers
- Door Bumpers
- Door Guides
  - Floor Mounted
  - Side Mounted
- Stay Rollers
- Jamb Latches
- Center Latch
- Door Pulls
- Door Frame Systems
  - Tab-Loc™
  - Easy-Frame®
  - Max Easy-Frame®
  - Aluminum

## Accordion/Fold

- 5116 Box Rail
- Box Rail Brackets
- 47 Accordion Hangers
- Door Guides
- 835-24" Cane Bolt
- 512 or 129 Hinges
- Door Pulls
- Center Latch
- Door Frame Systems
  - Tab-Loc™
  - Easy-Frame®
  - Aluminum



# SLIDING DOOR FRAMES - TAB-LOC™



## Tab-Loc™ Steel Sliding Door Frame

The All Steel Sliding Door Frame available with 1-7/8" thick laterals. The 1-7/8" door is fabricated entirely from 16 gauge galvanized steel with self-flashing verticals having a durable, powder coated white finish. It has pre-finished, self-flashing verticals. It's lighter than wood, yet is much stronger to last a lifetime. It won't crack, warp, rot, swell or stick.

Steel Verticals available for 1-1/2" and 3-1/2" wood laterals. The 16 gauge galvanized steel verticals are pre-punched for nails and are self-flashing with a durable, powder coated white finish. Wood laterals simply slide into the Easy-Frame® steel verticals, and door siding slides into the flashing channel eliminating separate flashing.

# SLIDING DOOR FRAMES - TAB-LOC™

## Materials Checklist

1. Rail cover
2. Rail
3. Rail bracket
4. Hanger
5. Steel lateral
6. Pre-finished steel vertical
7. Door covering/siding
8. Guide rail bracket
9. Guide rail
10. Center guide & stop  
(for bi-parting doors)\*
  - 10a. Center guide  
(for larger, single doors)\*
11. Door stop (bottom mount)\*
  - 11a. Door stop  
(jamb mount)\*
12. Jamb latch\*
  - 12a. Center door latch  
(for bi-parting doors)\*
13. Door pull\*
14. Door astragal\*

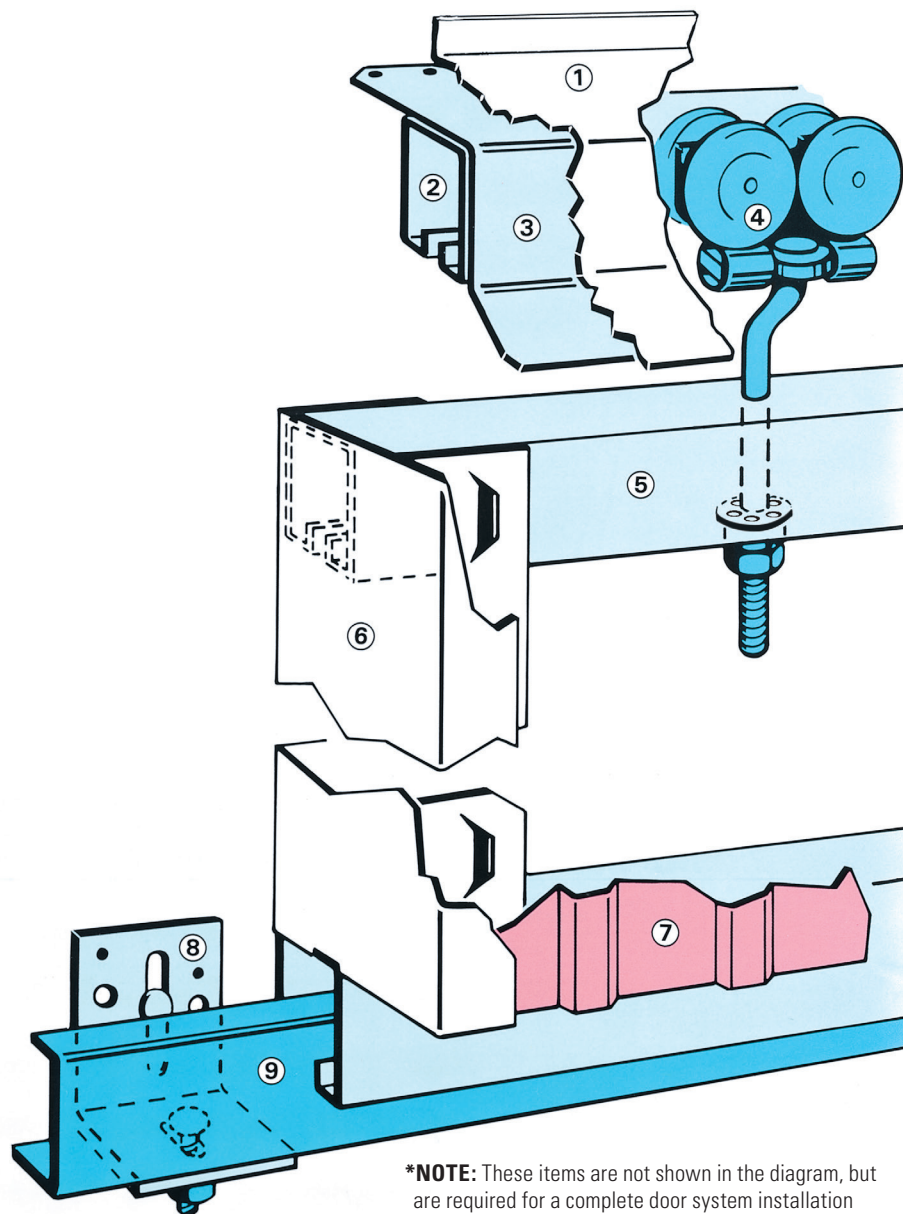

**\*NOTE:** These items are not shown in the diagram, but are required for a complete door system installation

## How to Figure Out a TAB-LOC All Steel Sliding Door

- What size opening to be covered? It's best to utilize standard sizes.
- Will door be double or single panel?
- Allow for panel to overlap jamb 1.5" at each end or add 3" to total width.
- Height should be the same as opening, which assumes door will lap trackboard 1/2"-1", leaving 1/2"-1" gap for clearance under door.
- Determine rail to be used (i.e. box, round) and determine style (ie. face mount, top mount). Include flashing if required and other accessories such as end caps, splice collars, flashing brackets, etc.
- Choose hanger to be used. Always use one designed for TAB-LOC. If door panel is 16c or wider, a third hanger should be used, or two tandem brackets.
- Figure two #6021 verticals for each door panel, remember, if opening is using a double door, you'll need four verticals.
- In National price book next to size of #6021, check asterisk number (i.e. \*6). This tells you how many laterals are needed.
- Order #6002 laterals to make width needed. If door panel is over 12' wide, add one extra to stiffen bottom of panel or you must order #6007's.
- Check next to #6002 size for another asterisk number (i.e. \*6) which tells you the minimum length of #6004 guide rail. Full length is best.
- Order #6004 guide rail. The heading will show number of #6005 guide rail brackets needed.
- Order #6005 brackets
- For a double door, order two #6006 center guide/stops and if door panel is over 12' wide and you did not add an extra #6002, order 2 #6007 center guides.
- Order the stops. Either #6008 base mounted or #6009 jamb mounted. If door is a single slide, one must be a #6008.
- Order jamb latches #1262 or #1263 and center latch #1253.
- If needed order #6019 Reinforcing Kit.
- Order #6 pulls if desired, preferably white.
- If desired, order a #6000T assembly tool.
- If door is bi-parting, order #6027 Astragal.
- If needed, order #6003 Stiffener Strip.

# SLIDING DOOR FRAMES - TAB-LOC™

## TAB-LOC lets one man assemble a steel door frame in 10 minutes.

The secret is our exclusive, patented locking tabs. These built-in fasteners are pre-punched into the frame members. Just bend the tabs down into matching slots for a square, tight, permanent steel door frame. Unlike any other door frame, you don't even need a level area for assembly. Once you're familiar with TAB-LOC, 10 minutes is all it takes to get a frame ready to attach the siding. In fact, the door can be completed and hung in under an hour to previously installed rail.

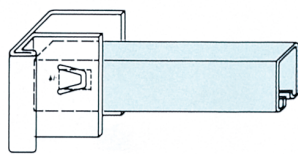

1. Align tabs over slots in cross members.

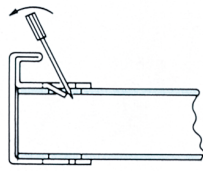

2. Insert screwdriver blade to start tab.

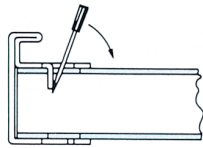

3. For best results assembling TAB-LOC frames, lay the components face down and set the tabs on the back side fully. Turn the frame over and set the front side tabs fully. Larger doors may be assembled on saw horses with the front side up and by setting the tabs on the back side of the door by reaching up from the underneath side eliminates turning of the door. Install the hangers in the frame.

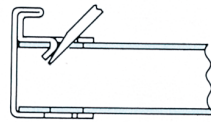

4. Lock tabs permanently with our special tapered tool #6000T.

Measure diagonally to square the frame, attach the steel siding. Do not hang the frame before the siding is applied.

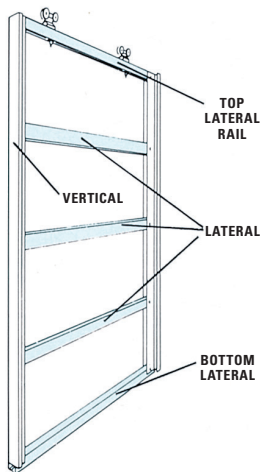

**To Shorten Door Lateral**  
Cut off desired amount and replace the square hole lost in the cut-off with 7/8" diameter round hole.

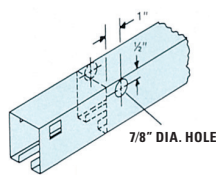

**To Shorten Door Vertical**

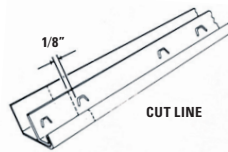

## Applications for installing sliding door on building.

The secret is our exclusive, patented locking tabs. These built-in fasteners are pre-punched into the frame members. Just bend the tabs down into matching slots for a square, tight, permanent steel door frame. Unlike any other door frame, you don't even need a level area for assembly. Once you're familiar with TAB-LOC, 10 minutes is all it takes to get a frame ready to attach the siding. In fact, the door can be completed and hung in under an hour to previously installed rail. The secret is our patented TAB-LOC system.

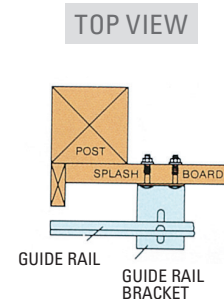
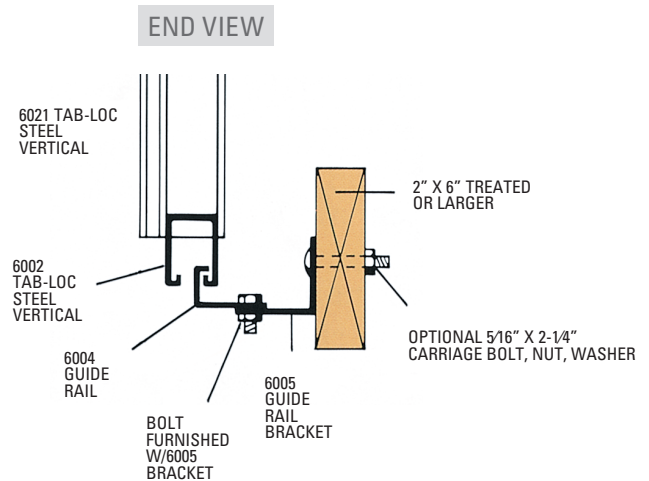
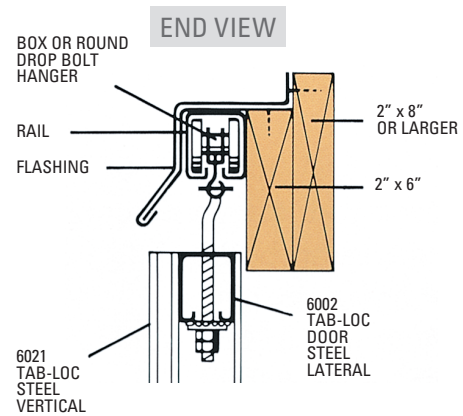

# SLIDING DOOR FRAMES - EASY FRAME<sup>®</sup>

## Easy Frame<sup>®</sup> Steel & Wood Frame

for 1 1/2" and 3 1/2" wood laterals for Box and Round Rail Systems

### Materials Checklist

1. Rail cover
2. Rail
3. Hanger
4. Wood lateral (top) (2" x 6")
5. Pre-finished steel vertical
6. Wood lateral (bottom) (2" x 6")
7. Door covering/siding
8. Continuous bottom guide rail
9. Guide rail bracket
10. Guide rail
11. Center guide & stop (for bi-parting doors)\*
  - 11a. Center guide (for larger, single doors)\*
12. Door stop (bottom mount)\*
  - 12a. Door stop (jamb mount)\*
13. Jamb latch\*
  - 13a. Center door latch (for bi-parting doors)\*
14. Door pull\*
15. Door astragal\*

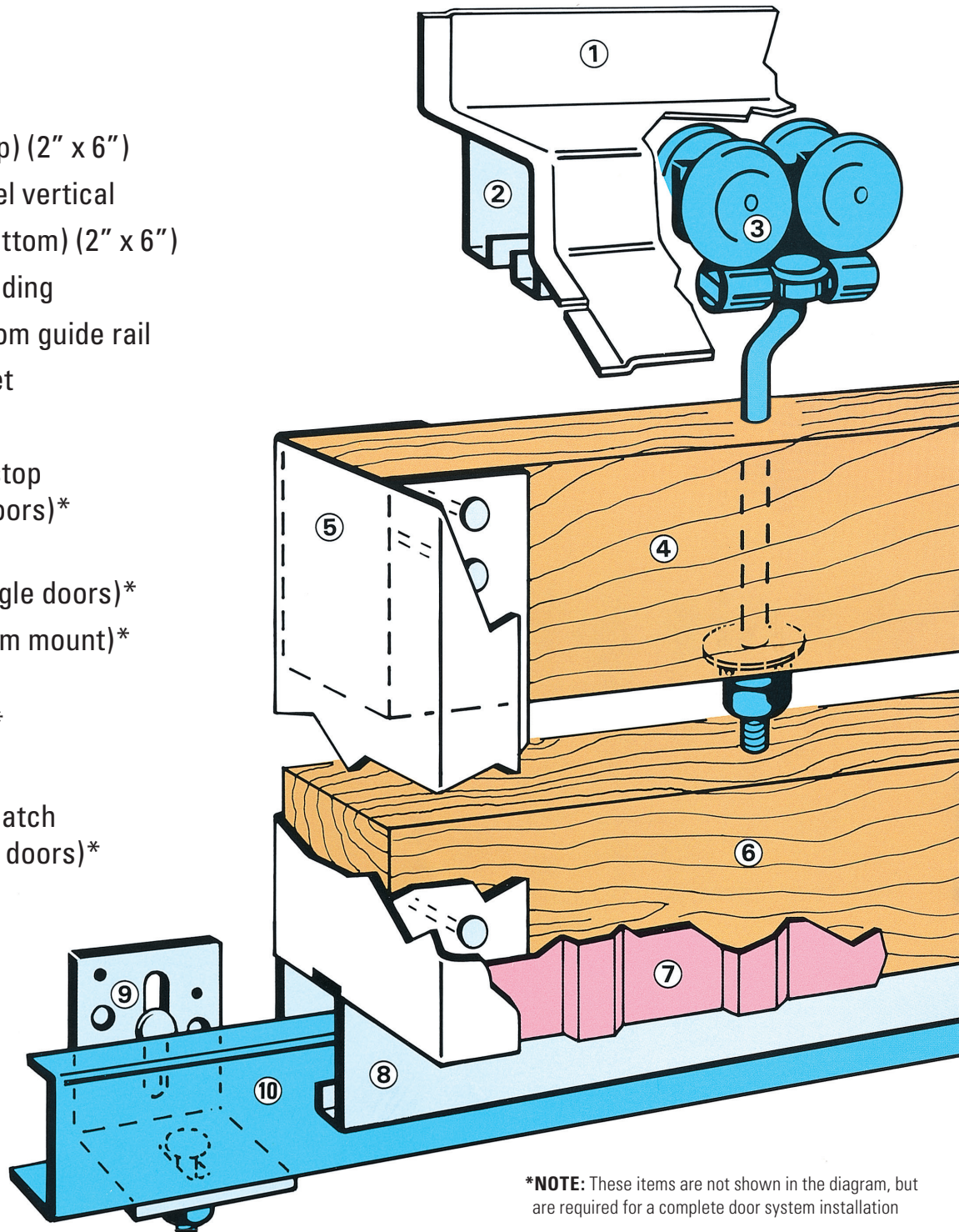

**\*NOTE:** These items are not shown in the diagram, but are required for a complete door system installation

# SLIDING DOOR FRAMES - EASY FRAME®

## 1-1/2" Thick Door

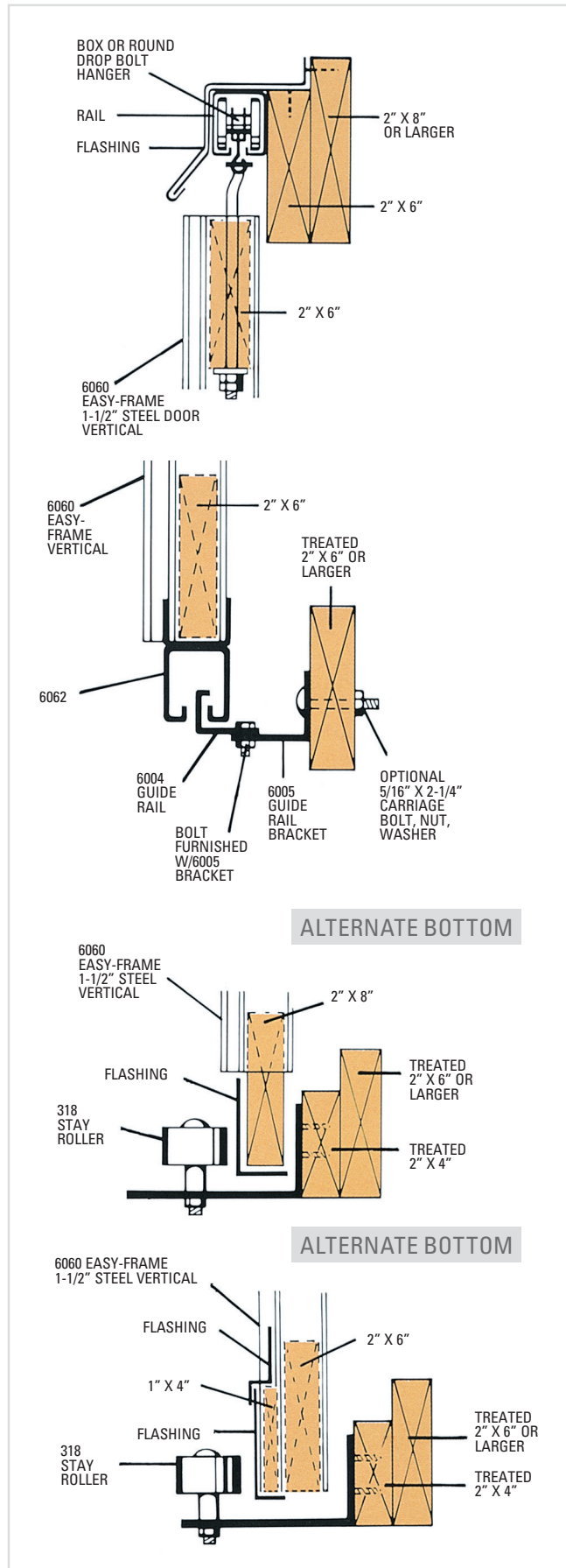

## 3-1/2" Thick Door

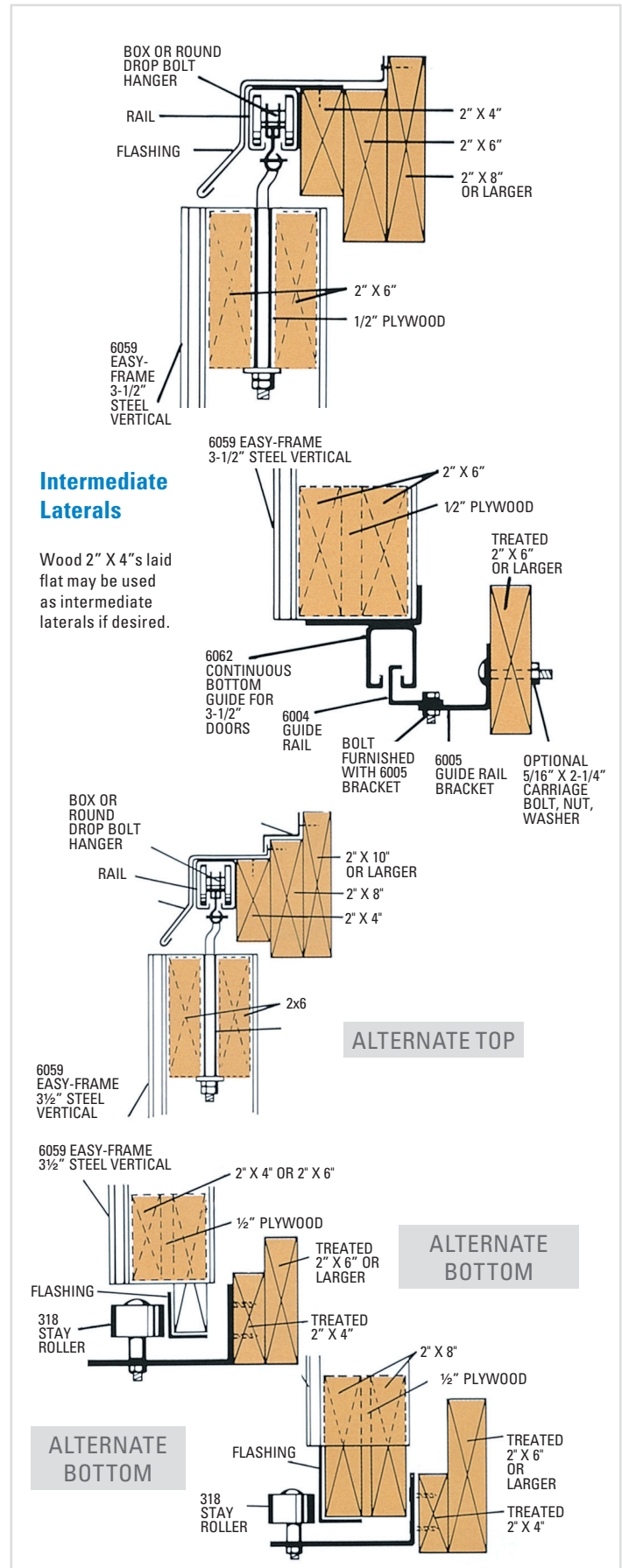

# SLIDING DOOR FRAME ACCESSORIES

## TAB-LOC™



**6021 Door Verticals**—Pre-finished, self-flashing, 16 gauge galvanized steel verticals. Door covering slides into channel of vertical for a clean, smooth fit. No flashing needed—vertical provides a clean, finished edge. Available in 7–17 ft. in one-foot increments.

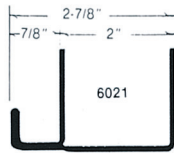

**6002 Door Laterals**—The galvanized 16 gauge laterals are pre-punched at each end for easy attaching to vertical members. All laterals have hanger holes pre-punched and can be used as either top, bottom or intermediate door members. Available in 4–20 ft. sections.



**1253 Center Door Latch**—Cam action, adjustable hook holds bi-parting doors tight. For TAB-LOC™ or EASY-FRAME® doors 1 1/2" or thicker.



**6000T TAB-LOC™ Assembly Tool**—This tool is helpful in bending the special locking tabs into slots on frame.

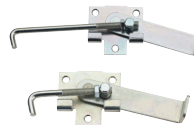

**1262/1263 Jamb Latches**—Cam action and adjustable hook holds door firmly against the jamb. 1262 has 7 in. hook; 1263 has 4 in. hook.



**6003 TAB-LOC™ Stiffener Strip**—12¢ length used to strengthen 14¢ and above #6021 TAB-LOC™ verticals when used in high wind areas. Flat strip slides into vertical before laterals are installed.

## Easy Frame®



**6060 1/2" Door Verticals**—Self-flashing verticals with powder coated white finish over galvanized 16-gauge steel. Pre-punched on 24" centers for attaching 1/2" lateral members.

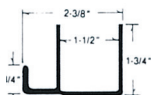

**6059 3/2" Door Verticals**—Self-flashing verticals with powder coated white finish over galvanized 16-gauge steel. Pre-punched for attaching 3/2" lateral members. Also available in non-punched 16-gauge galvanized finish.

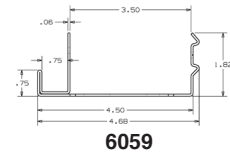

**6061 1/2" Continuous Bottom Guide**—For use on wood frame doors. When nailed to the bottom of a 1 1/2" wood framed door, the continuous bottom guide engages with the No. 6004 Guide Rail to prevent damage to door or building.

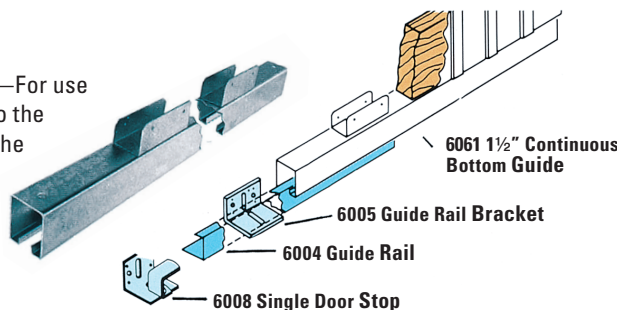

**6062 3/2" Continuous Bottom Guide**—Same as 6061 Bottom Guide for attaching to 3/2" wood framed doors.

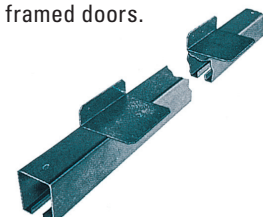

# SLIDING DOOR FRAME ACCESSORIES

## TAB-LOC™ & Easy Frame® Accessories



**6004 Guide Rail**—Engages the bottom lateral of TAB-LOC™ doors to hold the door in place and prevent wind damage. Fastens to building with No. 6005 Guide Rail Bracket. Guide rail also used with 6061/6062 Continuous Bottom Guides.



**6007W Center Guide**—For use in pairs. The 6007W is a heavy-duty center guide for single or bi-parting MAX EASY-FRAME® doors and is recommended for single doors 16 foot and wider, plus all bi-parting MAX EASY-FRAME® door systems. Should be installed in the center of the opening and works with the 6053 bottom lateral.



**6006 Center Guide and Stop for Bi-Parting Doors**—For use in pairs. The 6006 is a heavy-duty center guide and stop that engages bottom lateral of TAB-LOC™ doors in closed position. Also used with 6061/6062 Continuous Bottom Guide.



**6005 Guide Rail Bracket**—For use with No. 6004 Guide Rail. Slotted hole in each leg allows both lateral and vertical adjustments. Bolts, nuts and washers included.

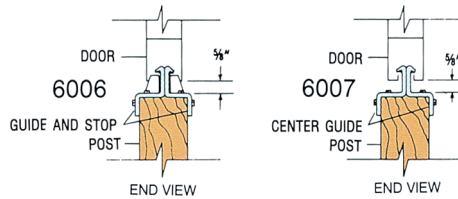

**6008 Single Door Stop**—Engages bottom of single TAB-LOC™ door in the open and closed position and bi-parting doors in the open position holding them firmly against the building. This can also be used on wood framed doors using the No. 6061 or 6062 Continuous Bottom Guide.



**6007 Center Guide for Single Doors**—For use in pairs. The 6007 is a center guide for single TAB-LOC™ door and is recommended for doors 12 foot and wider. This should be installed in center of opening. Also used with 6061/6062 Continuous Bottom Guide.



**1254 Center Door Latch**—Cam-action, adjustable hook holds bi-parting doors tight. For wood doors 1 1/2" or thicker.

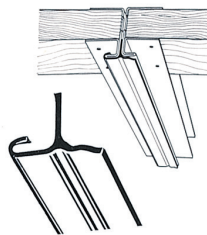

**6027 Door Astragal**—A pre-finished, white, extruded aluminum used to cover the gap between bi-parting doors. The unique design allows it to wrap around the flashing channel of the vertical. Astragal fits both TAB-LOC™ and EASY-FRAME® doors and attaches with pop rivets. Available in 10, 12, 14, and 16 foot lengths.



**1264/1265 Jamb Latches**—A cam-action latch designed to hold wood or metal sliding doors firmly in place against the door jamb. Also used on end gates, stake panels on trucks and other closures on farm buildings. Adjustable 4 inch hook. For right or left-hand installation. Handle of No. 1265 Latch can be used as a stop when door is in fully open position—simply flip handle approximately 180 degrees. No. 1264 Latch with 7 inch hook suitable for use where a long reach is necessary because of jamb construction.



**6009 Jamb Mount Door Stop**—Stops and holds door in both open and closed positions. The end with right angle projects slightly beyond the jamb and engages the vertical member of TAB-LOC™ or EASY-FRAME® door frame. Available in 3 sizes.

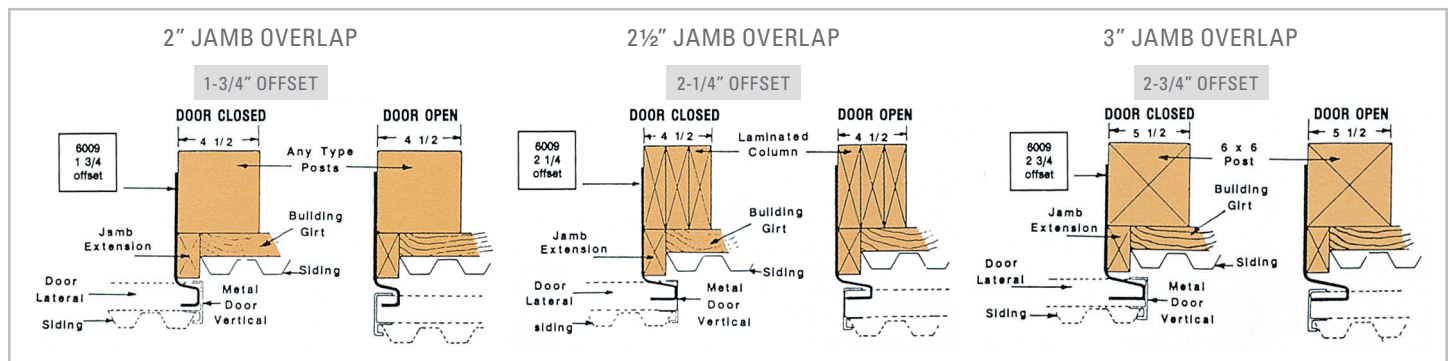

# SLIDING DOOR FRAME ACCESSORIES

## Additional Accessories

For a complete listing of all available hardware, see your retailer



**17 Door Bumper**—Strong, sturdy, steel barn door bumper. Has extra heavy ribs for strength. Easy to attach. For 2" thick doors.



**316 Adjustable Door Bumper**—Heavy-duty adjustable for single sliding or bi-parting door from 2½" to 3-1/8" thick.



**20 Single Door Guide**—Adjustable to maximum 3" door.



**322 Door Guide**—Heavy-duty center floor guide for bi-parting and single sliding metal or wood doors. Smooth ramp on each side prevents tire cutting. Mounts on concrete floors with lag screws and shields or on a 6" x 6" post. A ½" rod or bolt inserted through hole in each side serves as a center stop for bi-parting doors.



**318 Stay Roller**—For heavy-duty use. Slots in frame provide adjustment for holding sliding doors against wood walls or posts. Sturdy steel frame. Reversible. For doors up to 3-3/4" thick.



**319—Heavy-Duty Stay Roller** with Derlin® wheel and 3/8" x 4-1/2" lag screw with expansion shield. For doors of any thickness.



**6 Door Pull**—Extra heavy for variety of applications. White vinyl coated, zinc, galvanized or black. Length 6-3/4", width 1-3/8".



**1134 Slide Bolt Latch**—For doors and gates swinging in or out. Handle serves as pull. May be padlocked. Zinc plated, galvanized or satin black finishes.



**1135 Latch**—Sturdy, easy-operating, all purpose latch. Handle serves as a pull; latches right or left. The latch bar securely attached with two sets of guides and back plates, which provide a bearing surface for the bar and eliminate "grooving" of the wood as bar is moved back and forth. Extra strong bar strike has rounded edges. Ideal for horse barns and livestock enclosures.



**1136 Stall and Gate Latch**—Ideal for horse and other livestock stalls, residential or rural gates, doors, etc. Automatic retractable bolt clears entry. Rounded edges protects livestock. Right or left hand application. Zinc plated with weather proof finish.



**25 Swinging Door Latch**—Heavy-duty self-latching. Designed for installation on 3/4" to 2-1/4" thick doors. Bolt has rounded face to insure easy latching. Handle designed to prevent flattening when door swings back against building. Available for 3" door thickness. Available in zinc, black and stainless steel finish. Packed with hold-open catch.



**835 24" Cane Bolt**—Adjustable throw. Self-locking when mounted vertically.



**19 Door Bumper**—For 2-3/4" thick doors. A rugged, heavy-duty doorstop.



**317 Adjustable Door Bumper**—For by-passing or single sliding doors of greater thickness than No. 316 will accommodate. For 4-1/2" to 6" thick doors.



**20-2 By-passing Door Guide**—Adjustable to maximum 3" door.



**325 Door Guide**—Extra wide guides ideal for corrugated metal-clad doors. Easy to install. Fasteners not furnished, but guides have holes for spikes as well as larger holes for 3/8" lag-screw mounting. Guide is adjustable for doors 5" x 5-1/2" thick. Curved section of guide may be turned sideways allowing straight access when installing screws.



**18 Stay Roller**—Embossed frame with two wings provide greater bracing and holding strength than conventional single-support, corner-iron frame. Derlin® wheel assures rust-free operation. Adjustable. For doors up to 2-1/4" thick.



**13B Latch**—Similar to No. 13 but furnished with extra strong bar strike with rounded edges. Sturdy one-half inch thick bar strike eliminates breakage. Can be padlocked. Cam action between handle and bar strike holds door tightly closed preventing door rattle.



**6017 Adjustable Reinforcing Strap**—Distributes the weight of door equally between the top and 2nd lateral by securely fastening them together. Adjustable from 30.50 inches to 19.38 inches. Used on doors with 3-1/2" laterals at hanger locations.



**6018 Rigid Reinforcing Strap**—Distributes the weight of door equally between the top and 2nd lateral by securely fastening them together Fixed size of 30.50 inches. Used on doors with 3-1/2" laterals at hanger locations.



**6019 Hanger Reinforcing Kit**—Boxed extension kit attaches to drop bolt hangers (box or round styles) to allow weight of door to be carried by both top and 2nd lateral in door. Kit includes: 2 - 1/2" x 36" threaded rod, 2 - 1/2" couplers, 2 - 1/2" flat washers, 2 - 1/2" flange nuts, 4 - 1/2" jamb nuts, and directions.



**2180 Turnbuckle Gate Hook and Eye**—Designed to draw large doors tight by twisting turnbuckle after door is hooked. Ideal for heavy warehouse, grain bin, or machine shed doors.

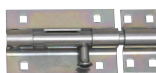

**832 Barrel Bolt**—Extra heavy for use on doors, stock rooms, farm buildings and situations where additional security is desired. Furnished with surface and universal strikes. Can be padlocked. Steel body with rust resistant, zinc-plated finish.



# SLIDING DOOR FRAMES - MAX EASY FRAME®

## MAX Easy Frame®



Tandem brackets double the capacity of the rail on larger door applications. Heavy doors roll smoother with the tandem bracket without the need for a center-mounted trolley hanger.



Round Rail



Box Rail

Both adjustable and rigid steel reinforcing straps provide added flexibility in the door frame assembly to distribute loads between laterals.

Self-flashing verticals are made of heavy duty, 16 gauge steel and are powder-coated white or galvanized to ensure durability and longevity.

Pull/center latch available as an accessory.

Assembly is simple and fast with Max Easy-Frame®. Our steel laterals easily slide into self-flashing steel verticals and attach with our self-drilling screws.

3-1/2" wide, top and intermediate laterals are available in 16 or 20 gauge steel depending on your door size and wind load requirements. These laterals can also be used in 1-1/2" doors.



Integrated bottom guide system is designed to engage the bottom lateral. This system holds the door firmly against the building to help prevent wind damage.

### A Variety of Accessories will complete your door system:

- Center guides and stops for single and bi-parting doors
- Jamb and center latches
- Pulls
- Astragals for bi-parting doors
- Tandem brackets for heavy doors

To learn how this door frame system can save you both time and money, please contact the National Farm and Commercial Sliding Door Systems Team at 800.346.9445 or visit [www.natman.com](http://www.natman.com)



# SLIDING DOOR FRAMES - MAX EASY FRAME®

## Assembling & Installing

### 3.5" Max Easy-Frame® Steel Doors

#### MAX EASY-FRAME PARTS



#### Recommended Trolley & Tandem Bracket

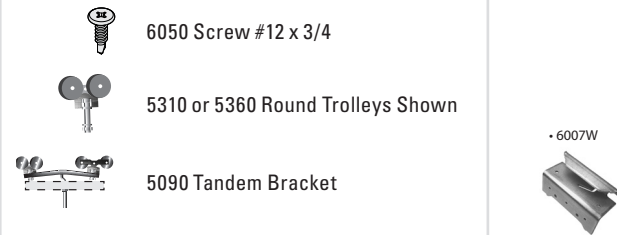

#### STEP 1

### Preliminary layout:

Once it is determined that verticals are the right length for the door height and laterals are the right length for the door width, lay verticals with front side of door up on 4 saw horses set diagonally. Evenly place the laterals into the verticals with the open side toward the ground. The top lateral should be flush with top of the verticals in 90 degrees. The 6052 bottom lateral is placed on top of these tabs and should have the lip that the siding sits on up towards the front side of the door.

#### STEP 2

### Connect the laterals to the front side of the verticals:

Check that frame is square by measuring diagonally in both directions. The top lateral and the second lateral should be spaced to accept the 6017 adjustable reinforcing strap 18" – 30-1/4" or the 6018 rigid reinforcing strap that requires 30-1/2" spacing. Hint, use the 6017 or the 6018 to achieve this proper spacing. The remaining laterals should be evenly spaced. After verifying correct spacing, using a #12 x 3/4" SD3 pancake quadrex self-drilling screw. (Recommended driver fit #2 size) drive 1 screw through the front side of the vertical into each of the laterals, while making sure the lateral is pushed tightly into the vertical. Warning, the screws going into each end of the 6053 bottom lateral must be installed 1/2" from the top of this lateral as to not interfere with the guide rail that will run inside this part after installation.

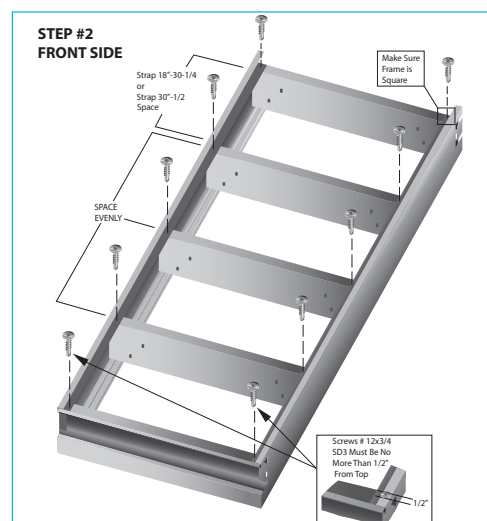
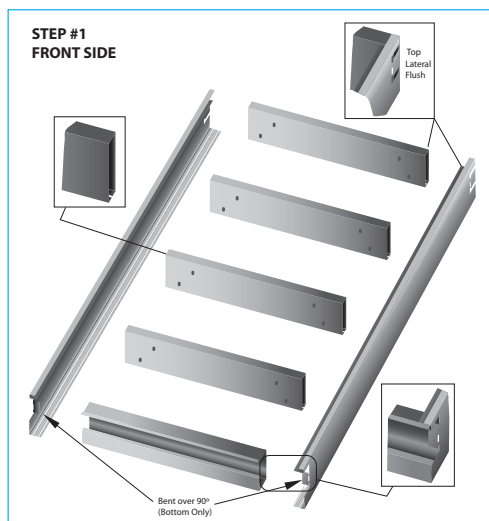

# SLIDING DOOR FRAMES - MAX EASY FRAME®

## STEP 3

### Connect the laterals to the back side of the verticals:

Re-check that frame is square by measuring diagonally in both directions. Frame can easily be moved into square at this time. After locating on the underside of the vertical the scored screw locator line (keeps your screws from walking) use the same #12 x 3/4" self drilling screws and drive screws into each of the legs of the laterals (2 screws per each end of each lateral from the underside), while making sure lateral is pushed tightly into the vertical. Just use 1 screw on the special 6053 bottom lateral, remembering to keep it 1/2" from the top of this lateral.

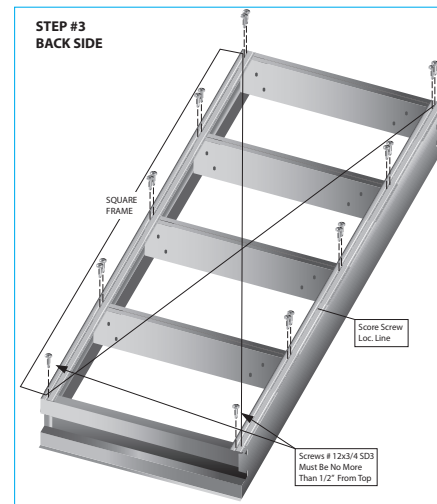

## STEP 4

### Install the 6017 or 6018 reinforcing straps:

Again using the #12 x 3/4" self drilling screws install between the top and the second lateral either your 6017 or 6018 reinforcing straps over each of the 1/2" hanger bolt holes located 1" from the inside edge of the door lateral (used with 1-1/2" track board), or over the 1/2" hole in the center of the lateral (used with 3" track board). **Warning**, the 6017 or 6018 reinforcing straps **must** be installed with the wide 3-1/2" side running parallel to the verticals.

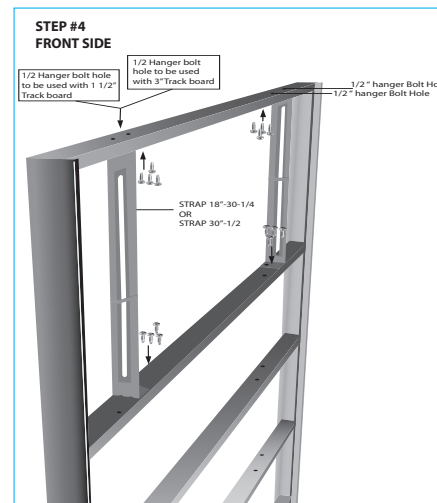

## STEP 5

### Install trolleys:

At this time install your trolley hangers. When using the 5090 tandem bracket install the completed assembly with hangers at this time. Make preliminary adjustment on hanger assembly to throw your door away from the building as far as possible. Final hanger adjustments should be made and secured after door is sided and is hung.

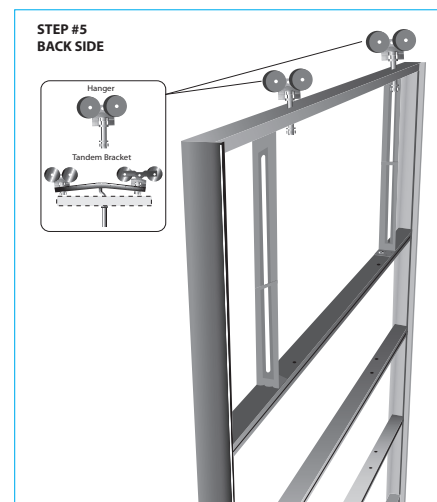

## STEP 6

### Hang the door:

Warning, the frame can not be hung on the track without any of the sliding attached. The best way to prevent damage to the door is to always lift the door by hand, but we realize that many doors will be lifted mechanically. Now is the final time to check that the frame is still square. Once that is done lay out your steel as it will go on the door, and install all the steel if lifting and hanging the door by hand. Install the center 1 or 2 sheets and both edge sheets if lifting mechanically. If lifting mechanically attach 1 chain as near as possible behind the leading hanger and reinforcing strap and attach the second chain as near as possible behind the trailing hanger and reinforcing strap.

# SLIDING DOOR FRAME ACCESSORIES



## 5090 Tandem Bracket

- 1) Insert hex head bolt through hole in trunnion. (see fig. "A")
- 2) **VERY IMPORTANT:** Thread hex nut onto bolt leaving 1/2" to 9/16" of thread exposed. (see fig. "A")
- 3) Inset bolt in hole of tandem bracket with crown of bracket up as shown. (see fig. "A")
- 4) Thread second nut with lock washer onto bolt and tighten securely.
- 5) Repeat for other truck assembly. Final product should look like fig. "B"

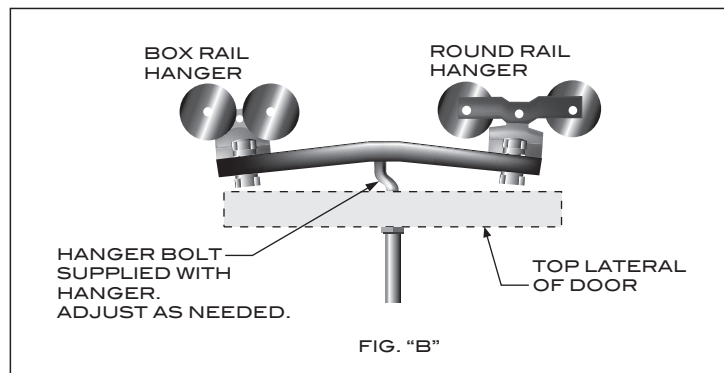
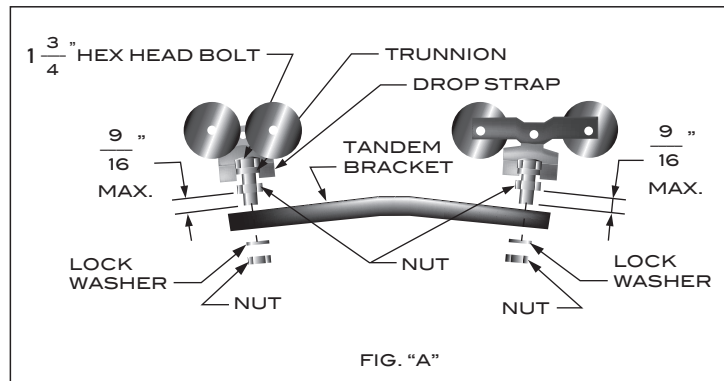
Can be used with either box or round rail to double the weight carrying capacity by adding an extra pair of hangers to a door panel, in lieu of using 3 hangers per door panel.



## 1266 Pull Center Latch

Pull Center Latch Parts®	
• 6050 #12x1 3/4 Self Drilling Screws .....	
• 1266 Center Latch .....	
• 1266 Pulls .....	

1266 Pulls require a minimum lateral width of 2-1/2"

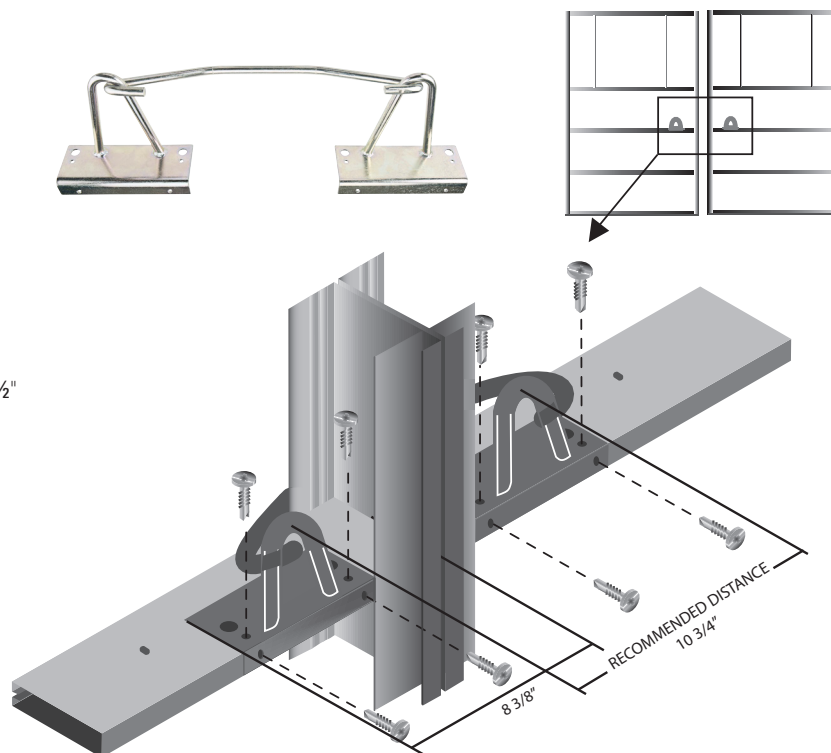

# ALUMINUM SLIDING DOOR FRAME

## Verticals

The type and number of aluminum verticals required for your door(s) depend on your application:

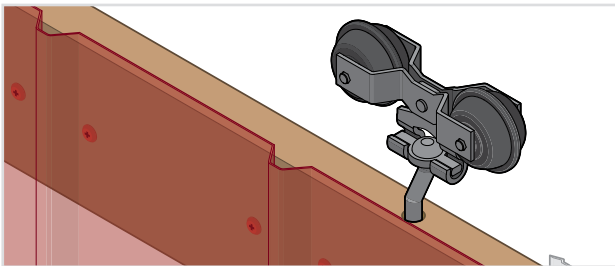

### Single Door

Use two 6063 C-channel verticals.



### Bi-Parting Doors

Use a 6064 kit, which contains three 6063 C-channel verticals and one H-channel vertical.

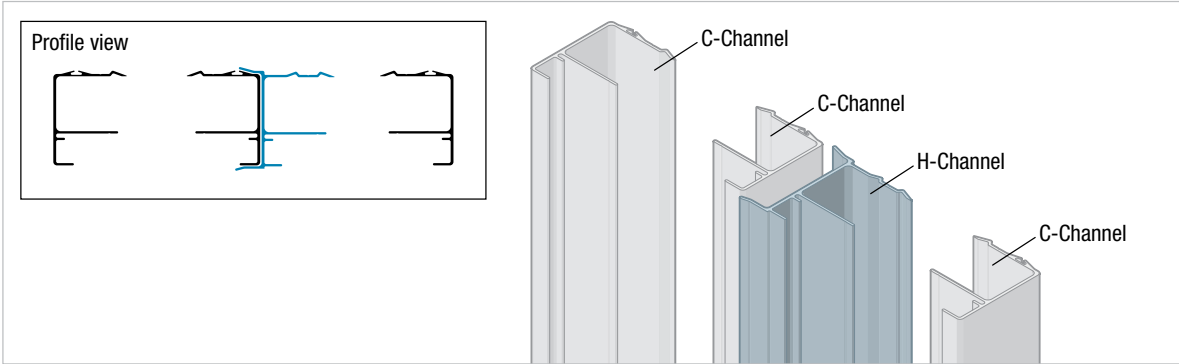

### Bi-Passing Doors

Use four 6063 C-channel verticals.

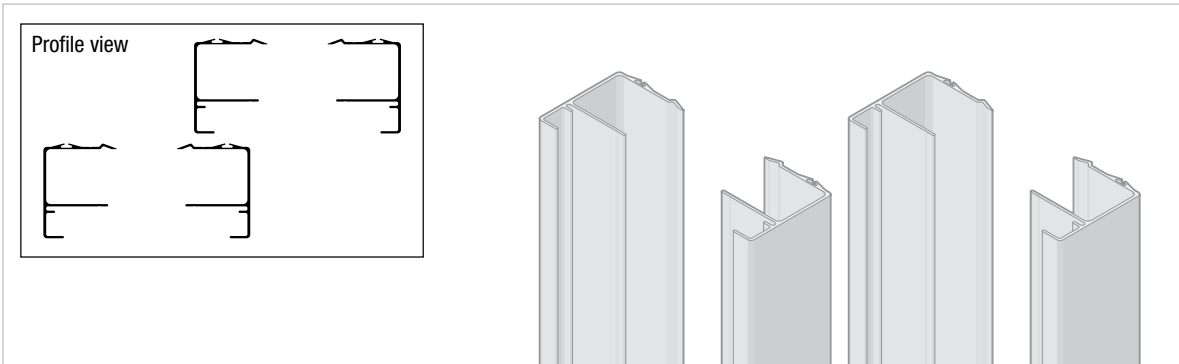

# ALUMINUM SLIDING DOOR FRAME

## Laterals

Wood laterals are recommended for this application.

### Required number of laterals

The number of laterals required for your door(s) is dependent on the desired door height.

Door Height	Number of Laterals
8'	5
10'	6
12'	7
14'	8
16'	9

### Lateral Dimensions

Use the following lumber dimensions for your laterals:

Lateral	Size
Bottom Lateral	2 x 8
Top Lateral	2 x 6
Middle Laterals	2 x 4

To determine the required number of 2x4s, subtract 2 from the total number of laterals required by your application.

### Additional lumber

If you are installing pulls on your door(s), it is recommended that you use an additional 2x6 on each door, adjacent to the aluminum vertical. The 2x6 will fit between two middle laterals on the side where the pull should be installed. The 2x6 will be cut to size after the door is assembled, and it holds the pull in place without the need to drill through the aluminum vertical.

## Bottom Guides

Utilize one of the following bottom guide options for your door(s):

### 6061 Continuous Bottom Guide

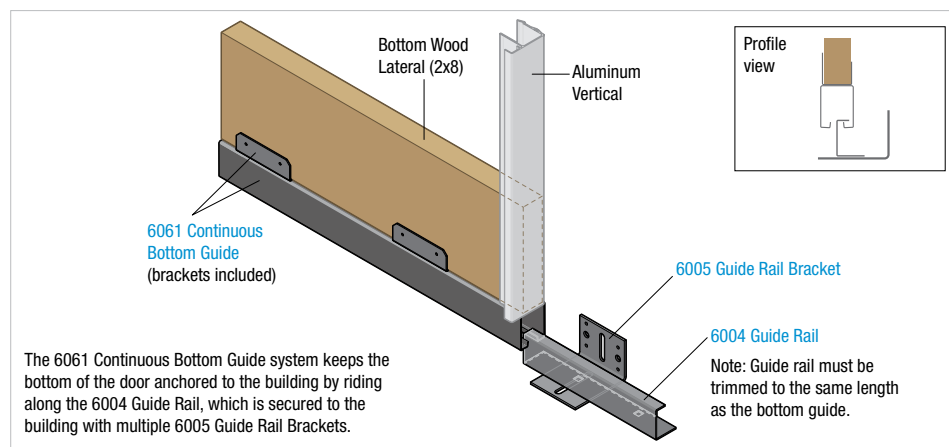

### 6065 Flashing Bottom Guide

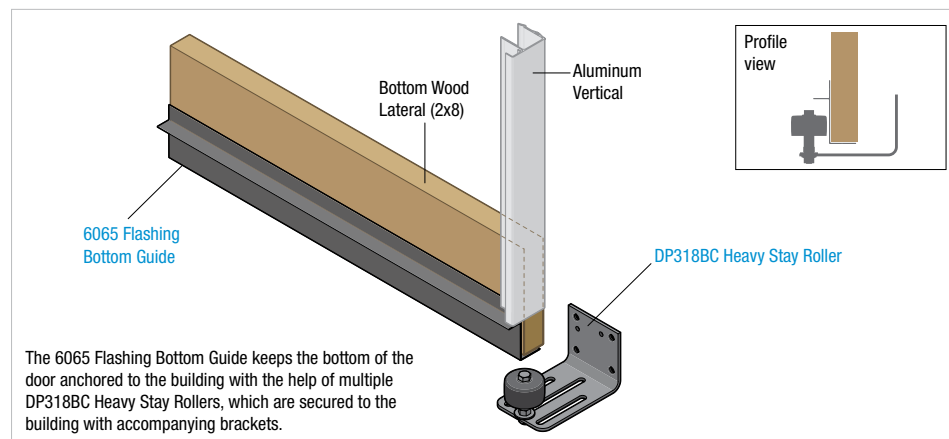

# ALUMINUM SLIDING DOOR FRAME

## Weather Stripping

If needed, weather stripping can be installed in the channels on the backside of the aluminum verticals.

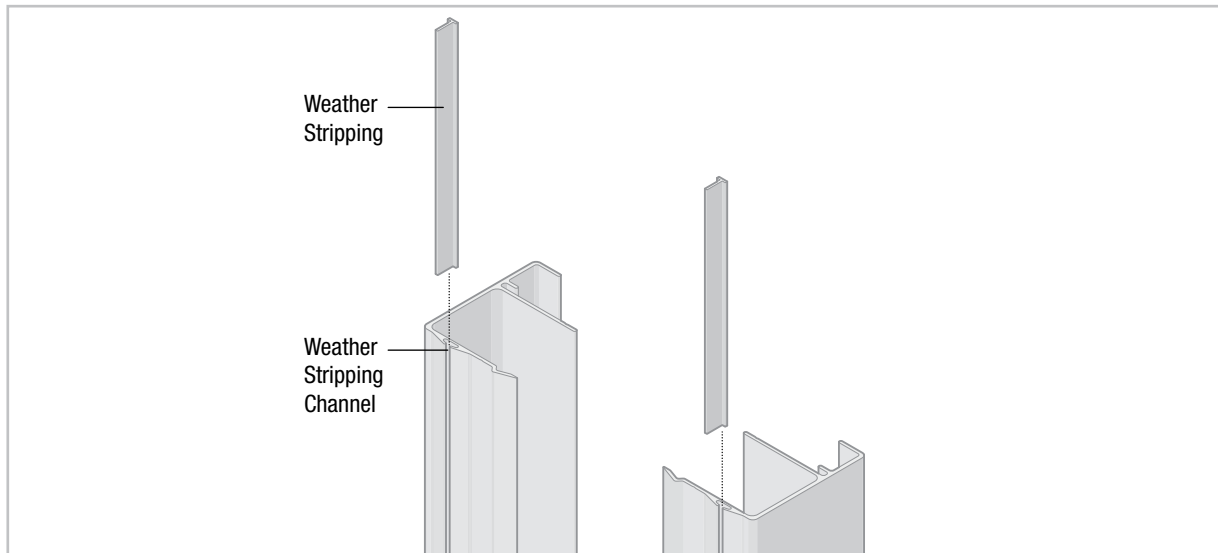

## Hangers

If a single door is 600 pounds or less, use two hangers to hang the door. If the door is more than 600 pounds, use three hangers or 5090 Tandem Hanger Brackets. Hangers with offset bolts are recommended for this application. Make sure to use the appropriate hanger for your track.

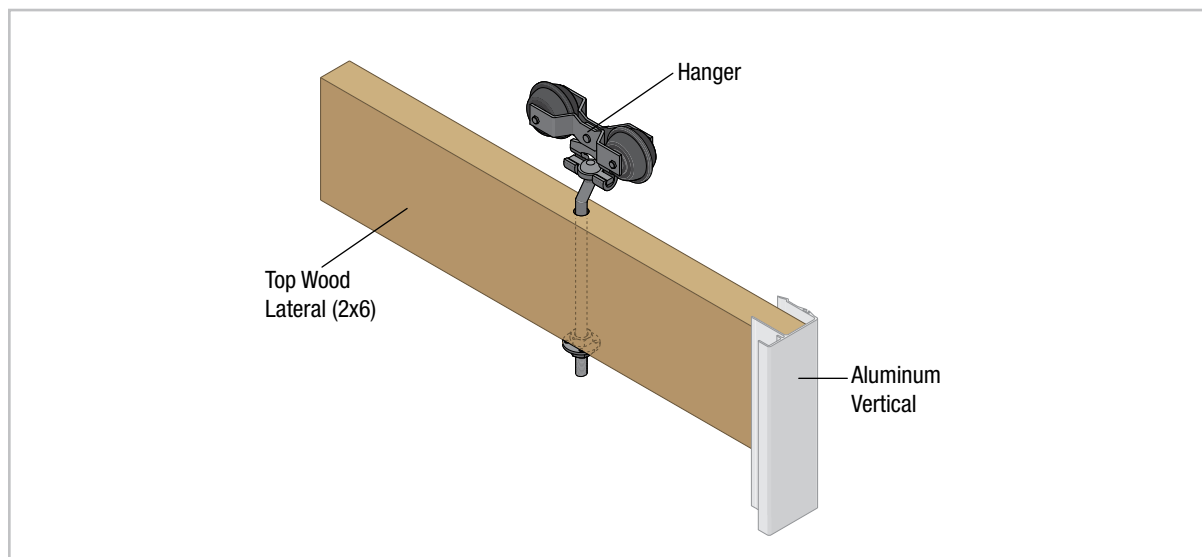

# ALUMINUM SLIDING DOOR FRAME

## Center Guides for Bi-Parting & Bi-Passing Doors

If installing two doors, it is necessary to add a center guide in the center of the door opening to keep the doors from swinging out.

### Bi-Parting Doors

Utilize a set of 322 Door Guides.

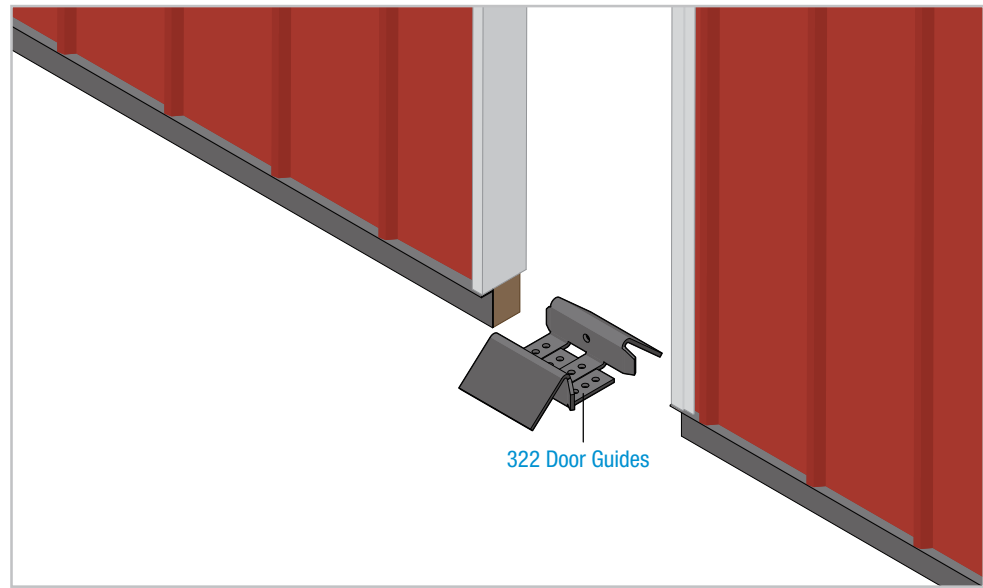

### Bi-Passing Doors

Utilize a set of 20-2 Door Guides.

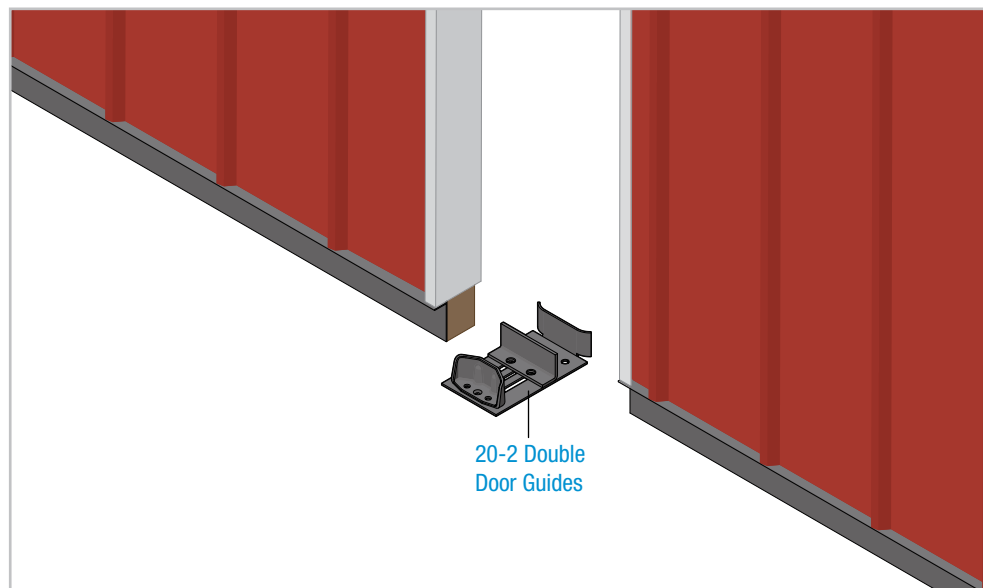



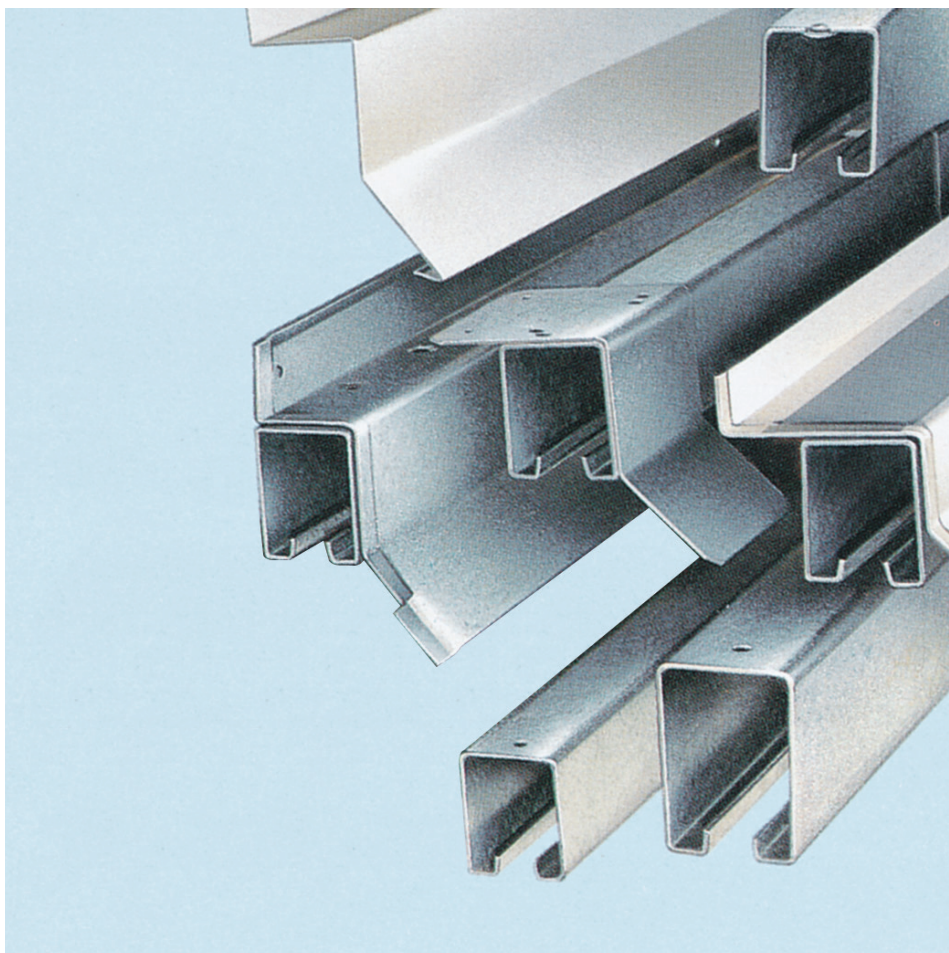

## A Complete Selection of Quality Rail

National Hardware has a complete selection of box rails that are designed for use on doors weighing up to 450 lbs (5116) or 600 lbs (5114). Our 450 lbs rated track meets ANSI/BHMA A156.14, Grade 2 specs. Our box rail is manufactured in the USA from galvanized steel for weather resistance and strength and is carefully formed to give an even tread to hanger wheels. National Hardware's box rail comes with optional pre-mounted brackets for fast, simple installations or can be used with many types of single and multiple brackets for a variety of door openings.



# BOX RAIL & ACCESSORIES

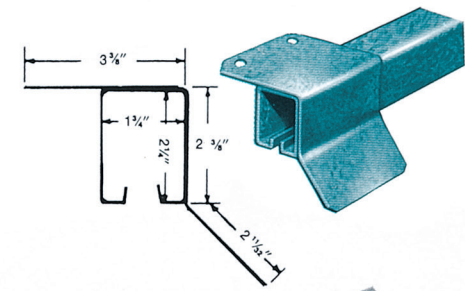

**No. 5100 Rail**—Top mount. 16 gauge galvanized steel. Mounting/flashing brackets welded to the rail on 2 foot centers. No separate brackets or rail couplings needed. For doors weighing up to 450 lbs. per panel.

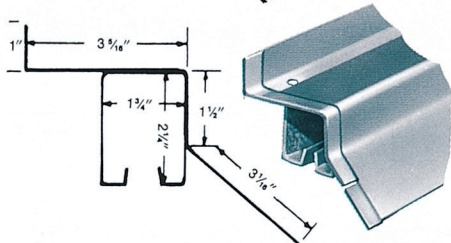

**No. 5103 Hi-Tensile Steel Rail**—Top mount. 16 gauge galvanized steel. For doors weighing up to 600 lbs. per panel when used with steel roller bearing hangers.

**No. 5104 White Covered Rail**—Top mount. 16 gauge galvanized steel. One piece design features a durable, white pre-finished cover, permanently welded to rail—fast, simple installation without mounting brackets. For doors weighing up to 450 lbs. per panel.

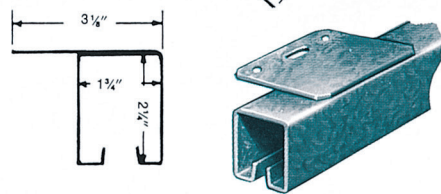

**No. 5105 Rail**—Top mount. 16 gauge galvanized steel. For interior doors, and exterior doors that travel inside the building and for horse stall doors. Mounting bracket welded to the rail on 2 ft. centers. Just nail the rail to the track board with ring-shank, neoprene washer nails. No separate brackets or rail couplings required. For doors weighing up to 450 lbs. per panel. For use where flashing is not required.

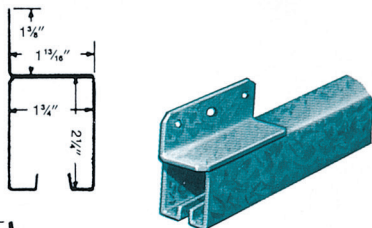

**No. 5110 Rail**—Face mount. 16 gauge galvanized steel. Welded-on mounting brackets on 2 ft. centers make rail installation fast and easy. Rail is simply attached to building with lag screws. No rail splicing brackets required, as end bracket of each piece of rail overlaps next length for perfect alignment and tight joint. For doors weighing up to 450 lbs. per panel.

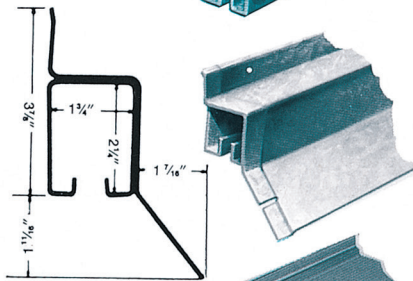

**No. 59 Covered Rail**—Face mount. 16 gauge galvanized steel. A face mounted rail with 18-gauge cover spot-welded on top of rail. No brackets required as cover provides a continuous bracket. For doors weighing up to 450 lbs. per panel.

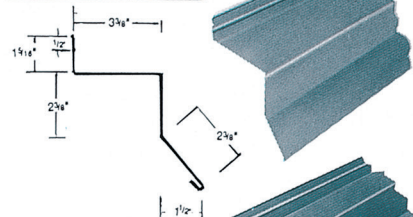

**No. 5120 Flashing**—For Easy-Mount® Rail No. 5100 and 5103. 10' sections, white finish, 28 gauge steel. End cap can be made by modifying flashing.

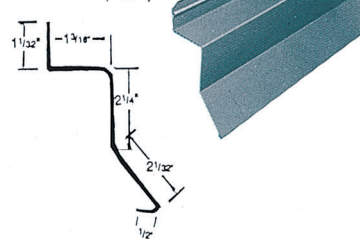

**No. 5122 Flashing**—For No. 59 rail. 10' sections, white finish, 28 gauge steel. End cap can be made.



**No. 5151 Flashing Bracket**—For 5120 flashing. Galvanized steel.

**No. 5102B Flashing Bracket**—For 3" track board.

## Applications & Accessories

**Face Mount**

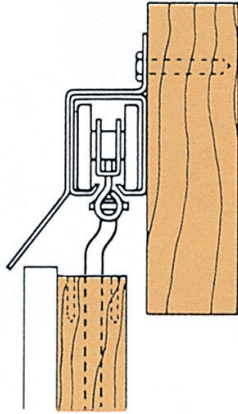

**Top Mount**

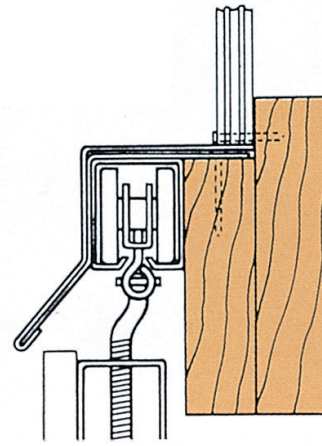

**Bracket Mount**

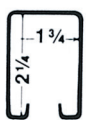
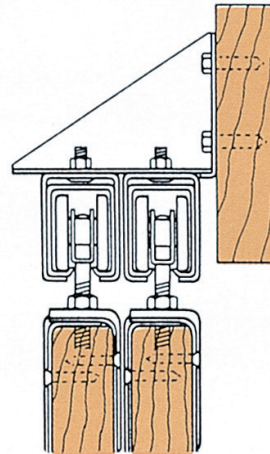

**No. 5116 Rail**—For doors weighing up to 450 lbs. per panel. 16 gauge galvanized steel rail bundled without fasteners or brackets. Can be used with various types of single and multiple brackets.

**No. 5114 Hi-Tensile Steel Rail**—Same as 5116, except for doors weighing up to 600 lbs. per panel when used with steel roller bearing hangers.

**No. 51ED End Caps**—Galvanized steel. For 16 gauge Rail. Used to cap rail end, and also used as center stop using 3/8" x 2" carriage bolt (not incl.).

# BOX RAIL & ACCESSORIES

## Brackets (Lag Bolts Included)

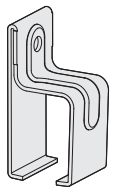

51F Single

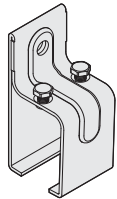

51G Splice

### No. 51F Wall Mount Single Bracket

Used at two foot intervals to hang rail to side of building.

### No. 51G Wall Mount Single Joint Splice Bracket

A splice bracket with set screws to join two lengths of rail.

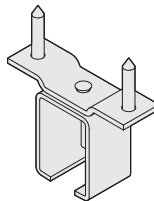

51J

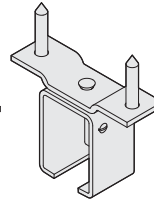

51JS

### No. 51J Ceiling Mount Single Bracket

For hanging rail to overhead mounting. Mounting plate swivels for various installations.

### No. 51JS Ceiling Mount Single Joint Splice Bracket

For joining two lengths of rail in overhead mounting. Mounting plate swivels for various installations.

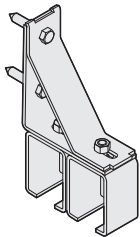

51H

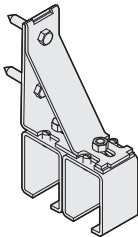

51HS

### No. 51H Wall Mount Double Bracket

Adjustable. For by-passing doors. Used at two foot intervals to hang rail to side of building.

### No. 51HS Wall Mount Double Joint Splice Bracket

Adjustable. For joining rail sections in a parallel run.

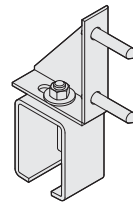

51M

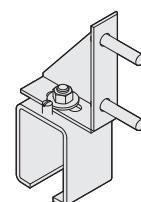

51MS

### No. 51M Single Bracket

Adjustable. Used to hang rail to the side of the building. Ideal for use on corrugated siding.

### No. 51MS Single Joint Splice Bracket

Adjustable. A splice bracket with set screws to join two lengths of rail in a single run. Ideal for use on metal-sided buildings.

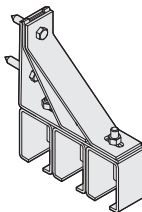

51K

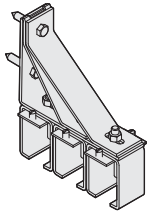

51L2

### No. 51K Wall Mount Triple Bracket

Adjustable. For triple by-passing doors. Used at two foot intervals to hang rail to side of building.

### No. 51L2 Triangle Only

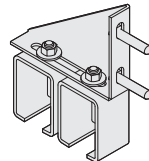

51M-2

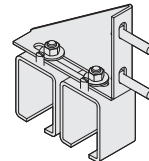

51MS-2

### No. 51M-2 Double Bracket

Adjustable. For by-passing doors. Used at 2 ft. intervals to hang rail to side of buildings. Ideal for metal-sided buildings.

### No. 51MS-2 Double Splice Bracket

Adjustable. For joining rail sections in a parallel run. Ideal for metal-sided buildings.

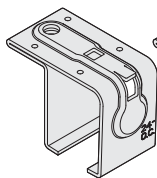

51TM

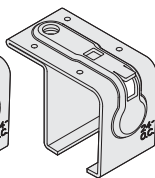

51TMS

### No. 51TM Single Top Mount Bracket

Top mount design so brackets can be installed on a 2 x 6 header board. Used at two foot intervals to hang rail. Compatible with 5438 & 5439 snap on flashing brackets

### No. 51TMS Single Top Mount Splice Bracket

For joining rail selections in a parallel run.

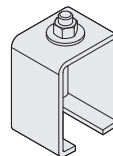

51HB

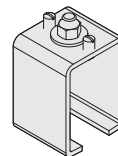

51HBS

### No. 51HB Box Rail Brackets Only

Replacement brackets for 51H, 51K, 51M and 51M-2 brackets.

### No. 51HBS Box Rail Brackets Only

Replacement brackets for 51HS, 51KS, 51MS and 51MS-2 brackets

For detailed technical information, please visit [www.natman.com](http://www.natman.com)



Delrin 500CL Bearings are permanently self-lubricating. Our economical Delrin bearing hangers roll easier and last longer than many competitive steel bearing hangers. Requires only 9 lbs of pressure to start rolling door.

Steel Rollers Each axle has 12 hardened and precision ground, alloy steel bearings. Requires only 4 lbs of pressure to start rolling door.

## Roll Easier • Last Longer

National Hardware offers Box Rail Hangers with Delrin or steel bearings. Our hangers are designed and manufactured using durable one piece, precision formed steel. National Hardware's Box Rail Hangers have a safe working load of 250 lbs or 300 lbs. We offer hangers in flexible or rigid types with a wide variety of functions.

# FLEXIBLE BOX HANGERS

## Delrin® 500CL Bearings | Steel Roller Bearings

### Offset Bolts

The hangers below are for use on wood frame metal-clad doors using 2 x 4 or 2 x 6 frame. Offset 9" bolt adjusts both vertically and laterally from inside the door. Connecting bolts threaded 7", adjusts laterally 1" by turning offset bolt for desired clearance. Packed with four washers, four hex nuts, two end caps per pair.



**No. 5022 Delrin® 500CL Bearings**—For use on wood frame doors up to 450 lbs.

**No. 5023 Delrin® 500CL Bearings**—Same as 5022 except includes 17, 3/8" x 2 1/2" lag bolts for mounting rail.

**No. 5024 Delrin® 500CL Bearings**—Same as 5022 except includes two 5151 flashing brackets for 5100 rail.



**No. 5062 Steel Roller Bearings**—For use on doors up to 600 lbs. when used with Hi-Tensile rails—5103 and 5114.

**No. 5064 Steel Roller Bearings**—Same as 5062 except includes two 5151 flashing brackets for 5103 rail.

The hangers below are for use with **TAB-LOC™ Steel Door Frames** and have vertical and lateral adjustments made from inside. Door bolt threaded 5 1/2". Offset 7 1/2" bolt allows 1" adjustment by turning bolt. Packed with two star washers, two hex nuts, two flange nuts and two end caps per pair.



**No. 5030 Delrin® 500CL Bearings**—For use on TAB-LOC™ steel frame doors up to 450 lbs.



**No. 5070 Steel Roller Bearings**—For use on doors up to 600 lbs. when used with Hi-Tensile rails—5103 and 5114.

### Door Straps



**No. 5040 Delrin® 500CL Bearings**—Flexible hangers for use on wood frame sliding doors, laterally and vertically adjustable. Packed with two end caps and bolts for attaching door straps. For use on doors up to 450 lbs. 5 1/4" Strap length.



**No. 5047 Delrin® 500CL Bearings**—Flexible hangers for use on wood frame sliding doors. Double door strap has opposing holes for bolt mounting. Laterally and vertically adjustable. Hangers are packed with two end caps and bolts for attaching door straps. For use on doors up to 450 lbs. 4 3/4" Strap length.



**No. 5041 Delrin® 500CL Bearings**—Flexible hangers for use on wood frame sliding doors. These hangers have vertical and lateral adjustments that can be made from outside the building. Offset bolt is threaded 4" with a lateral adjustment of 1" by turning bolt. For use on doors up to 450 lbs. 5 1/4" Strap length.

**No. 5042 Delrin® 500CL Bearings**—Same as 5041 except includes 9, 3/4" x 2" lag screws for rail.



**No. 5020 Delrin®**—Flexible with drop strap. For use on doors up to 450 lbs when used in pairs with box rail.



**No. 5080 Steel Roller Bearings**—Flexible hangers for use on wood frame sliding doors, laterally and vertically adjustable. Packed with two end caps and bolts for attaching door straps. For use on doors up to 600 lbs. when used with Hi-Tensile rails—5103 and 5114. 5 1/4" Strap length.



**No. 5087 Steel Roller Bearings**—Flexible hanger for use on wood frame sliding doors. Double door strap has opposing holes for bolt mounting. Laterally and vertically adjustable. Hangers are packed with two end caps and bolts for attaching door straps. For use on doors up to 600 lbs. when used with Hi-Tensile rails—5103 and 5114. 4 3/4" Strap length.

## Delrin® 500CL Bearings | Steel Roller Bearings

### Trucks



**No. 5000 Delrin® 500CL Bearings**—Truck only. Durable one piece, precision formed steel. For use with all rail. For doors up to 450 lbs.



**No. 5050 Steel Roller Bearings**—Truck only. Durable one piece, precision formed steel. For use on doors up to 600 lbs. when used with Hi-Tensile rails—5103 and 5114.

### Straight Bolts



**No. 5001 Delrin® 500CL Bearings**—Includes truck, connecting bolt and nuts. For use on doors up to 450 lbs. Bolt lengths available; 31/8", 4-1/2", 5", 5-1/2" and 6."



**No. 5051 Steel Roller Bearings**—Includes truck, connecting bolt and nuts. For use on doors up to 600 lbs. when used with Hi-Tensile rails—5103 and 5114. Bolt lengths available; 31/8", 41/2", 5", 51/2" and 6".

### Offset Bolts



**No. 5002 Delrin® 500CL Bearings**—For use on wood lateral doors. These rigid hangers have both vertical and lateral adjustments that can be made from inside the building after installation. Bolt threaded 4", adjusts laterally 11/2" by turning offset bolt for desired clearance. Included are two washers and two hex nuts for each bolt. Bolt sizes 81/2" or 101/2". For use on doors up to 450 lbs.



**No. 5052 Steel Roller Bearings**—For use on wood lateral doors. These rigid hangers have both vertical and lateral adjustments that can be made from inside the building after installation. Bolt threaded 4", adjusts laterally 11/2" by turning offset bolt for desired clearance. Included are two washers and two hex nuts for each bolt. Bolt sizes 81/2" or 101/2". For use on doors up to 600 lbs. when used with Hi-Tensile rails—5103 or 5114.



**No. 5005 Delrin® 500CL Bearings**—For use on wood frame sliding doors, laterally and vertically adjustable. Hangers are packed with two end caps and bolts for attaching door strap. Door strap is 51/4" long. For use on doors up to 450 lbs.

**No. 5005B Delrin® 500CL Bearings**—Same as No. 5005 except includes two 51F and one 51G rail brackets.



**No. 5055 Steel Roller Bearings**—For use on wood frame sliding doors, laterally and vertically adjustable. Hangers are packed with two end caps and bolts for attaching door strap. Door strap is 51/4" long. For use on doors up to 600 lbs. when used with Hi-Tensile rails—5103 and 5114.



**No. 5008 Delrin® 500CL Bearings**—Double strap hanger for use on wood framed by-passing sliding doors. Holes are staggered for screw mounting. Packed with screws and two end caps. Door strap is 43/4" long. For use on doors up to 450 lbs.



**No. 5009 Delrin® 500CL Bearings**—For round-the-corner or heavy folding door installations. Adjustable. Ball bearing swivels on hanger to assure smooth, easy operation. Packed with mounting bolts and two end caps. Door strap is 63/4" long. For use on doors up to 450 lbs.

# TYPICAL INSTALLATIONS - BOX RAIL

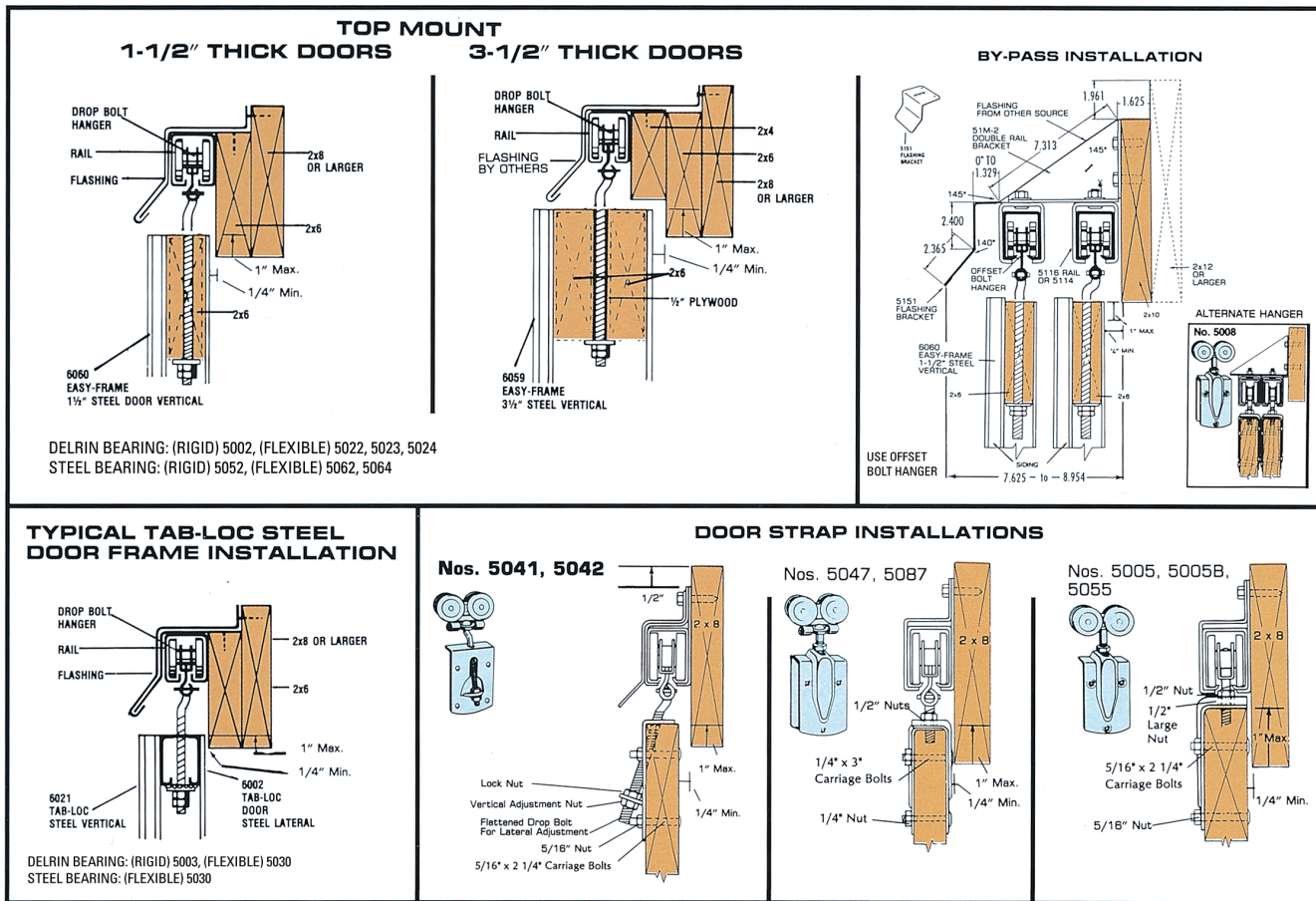

## 16 Gauge Rail & Hangers

Load Carrying Table (in pounds per door panel)

### Delrin 500CL Bearing Hangers

### Steel Roller Bearing Hangers

patent No. 4,642,844

Catalog #	5000	5001	5002	5005	5006	5008	5009	5022	5023	5024	5030	5031	5040	5041	5042	5047	5050	5051	5052	5055	5062	5064	5070	5080	5087
□ 59									450				450		450				450					450	
□ 5100		450						450		450	450	450							450		450	450	450		
□ 5103																	600		600		600	600	600		
□ 5104		450						450			450								450		450		450		
□ 5105			450	450	450			450			450					450			450		450		450		
□ 5110		450		450	450				450				450	450	450	450			450					450	
□ 5114																			600	600				600	600
□ 5116	450	450		450	450	450	450						450	450	450	450			450					450	

Many hangers are specially packaged for a particular rail; however, any hanger in this table can be used with any rail in this table for doors up to 450 lbs.

## Specialty Box Rail Hangers

### Lightweight Hanger



**No. 56 Hanger**—For doors up to 150 lbs. 51 series rail to bypass lightweight thin doors 7/8" max



**No. 47 Steel Roller Bearings**—Accordion door hanger for use in churches, schools, and auditoriums. Vertically adjustable. Mounting plate is NOT included. 150# capacity.

### Conveyor Hangers



**No. 48 Steel Roller Bearings**—Cast body. Single axle hanger is ideal for curtains in welding shops, spray booths, truck docks, and other industrial applications. For use with all rail. Hanger holds up to 150 lbs.



**No. 50C Steel Roller Bearings**—Cast body. Eye bolt hanger, with bumpers to protect wheels when hangers run together. For carrying electric cable on cranes and for use on conveyor systems. For use with all rail. Hanger holds up to 225 lbs.





## Round Rail & Round Hangers

### TRACKMASTER®

National Hardware's Trackmaster round rail and hangers are advanced design with flat top and sides for easier mounting and better stability. Designed for doors weighing up to 600 lbs. Trackmaster allows track to be self cleaning and smoother operation. Manufactured in the USA from galvanized steel for weather resistances and strength.



## TRACKMASTER®

### Benefits

TrackMaster rail and hangers combine the easy mounting features and stability of box-rail with the smooth operation of round. The result is a round-rail system that is easier-to-install, easier-to-operate, self-cleaning, and longer-lasting. Supporting a 600 lb. door, TrackMaster hangers have been torture tested without failure through over 10,000 cycles of opening and closing a door! (That's opening and closing the door once a day for 30 years!)

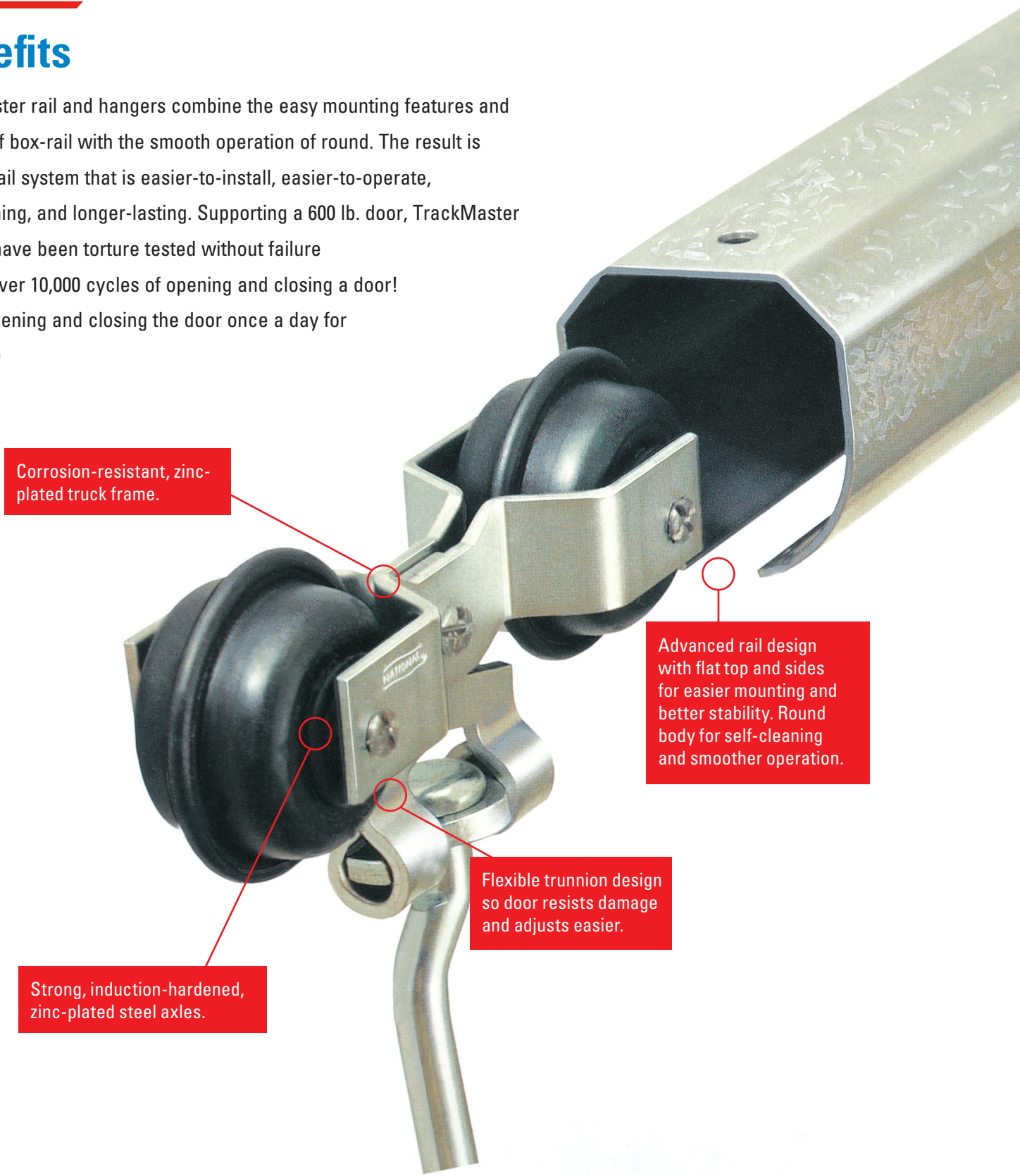

Corrosion-resistant, zinc-plated truck frame.

Advanced rail design with flat top and sides for easier mounting and better stability. Round body for self-cleaning and smoother operation.

Flexible trunnion design so door resists damage and adjusts easier.

Strong, induction-hardened, zinc-plated steel axles.

# TRACKMASTER® ROUND RAIL & ACCESSORIES

## TrackMaster™ is interchangeable with other brands of round rail and hangers.

TrackMaster™ Hangers can be used with Cannonball® and Combo® brand\* rail—and vice versa. So, when you add National Trackmaster Round, you can supply replacement components to current customers.

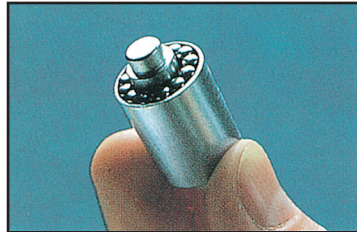

Precision ground and hardened steel roller bearings for longer, smoother operation.

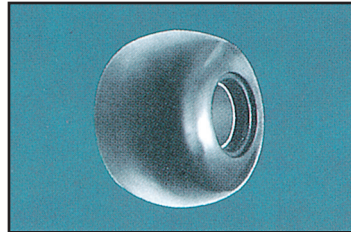

Quiet, smooth rolling Delrin® wheels have steel roller bearings and hold up to a 600 lb. door per pair.

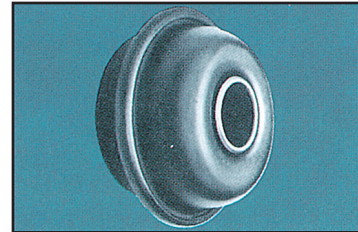

Hardened steel wheels with steel roller bearings hold up to a 600 lb. door.

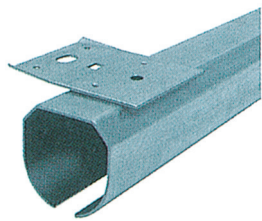

### Galvanized Steel Round Rail

- Easier mounting and alignment with flat top and sides.
- Self-cleaning and self-aligning round body.

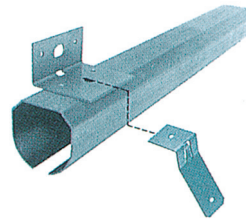

### Unique Snap-On Flashing Bracket for 1 1/2" or 3 1/2" Thick Doors

- Simplifies rail installation. Just attach rail into track board and "snap-on" flashing brackets—then add flashing.

All new brackets can be used with a snap-on flashing bracket



## TrackMaster "Round" Checklist

### Rail

5400	Plain Rail (6' – 24')
5430	Face Mount Rail (8' – 20')
5433	Top Mount Rail (8' – 20')
5460	Top Mount Rail with Flashing Brackets (8' – 20')

### Door Frames

TAB-LOC™ (Steel) 6021, 6002, Easy Frame® Verticals (Steel & Wood) 6060, 6059 Max Easy Frame® (Aluminum)

### Bottom Guide

Continuous Bottom Guide 6061, 6062, 6053

### Accessory Hardware

Pulls, Stops, Latches, etc.

### Hangers

#### Delrin® Wheels, Flexible Trunnion, Steel Roller Bearings

5301	Straight Bolt 3-1/8" or 4 1/2"
5302	Offset Bolt (Wood Door)
5306	Heavy Single Door Strap
5310	Offset Bolt (TAB-LOC™)
5330	Door Strap
5332	Door Strap with Outside Adjustment

#### Hardened Steel Wheels, Flexible Trunnion, Steel Roller Bearings

5351	Straight Bolt 3-1/8" or 4 1/2"
5352	Offset Bolt (Wood Door)
5360	Offset Bolt (TAB-LOC™)
5380	Door Strap
5382	Door Strap with Outside Adjustment

### Flashing & Flashing Brackets

5436	Snap-On Flashing Bracket (1 1/2" Door)
5437	Snap-On Flashing Bracket (3 1/2" Door)
5450	Face Mount Flashing (1 1/2" Door)
5455	Top Mount Flashing (1 1/2" Door)

### Rail/Mounting Brackets

5405	Splice Collar
5408	Rail End Cap
5410	Single Bracket
5411	Single Splice Bracket
5412	Adj. Single Bracket
5413	Adj. Single Splice Bracket
5414	Adj. Double Bracket
5415	Adj. Double Splice Bracket
5418	Rail Bracket Only
5419	Splice Bracket Only

\*Cannonball® and Combo® are registered trademarks of Cannonball Industries, Inc. and Combo Corp.

# TRACKMASTER® ROUND RAIL ACCESSORIES

## TrackMaster® Round Rail

### No. 5400 Plain Rail —

Separate face-mount brackets.  
For doors weighing up to 600 lbs. per panel. Fourteen gauge galvanized steel bundled without fasteners or brackets. For use with various types of single and multiple brackets. In 6' to 24' lengths.

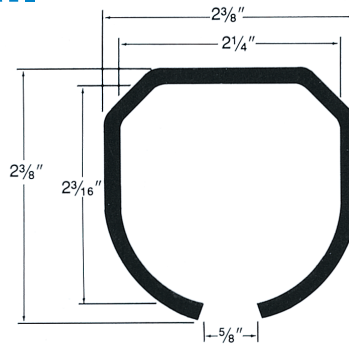

## Rail Brackets (Lag Bolts Included)

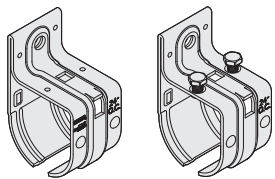

5420

5421

### No. 5420 Single Bracket

Wall mount. Used at two-foot intervals to bring rail to side of building. 10 each (100-006)

### No. 5421 Single Splice Bracket

Wall mount. A splice bracket with set screws to join and hold two lengths of rail together. 5 each (100-007)

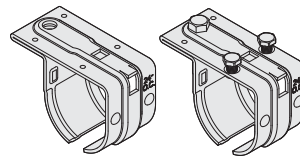

5420

5421

### No. 5420 Single Bracket-Top Mount

Top Mount design so brackets can be installed on a 2 x 6 header board. Used at 2ft intervals. 10 each (N100-008)

### No. 5421 Single Round Splice Bracket-Top Mount

Top mount splice bracket with set screws to join and hold two lengths of rail together. 5 each (N100-009)

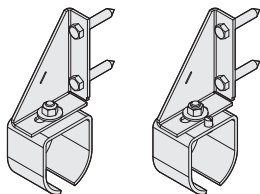

5412

5413

### No. 5412 Adjustable Single Bracket

Wall mount. Used at two-foot intervals to hang rail to side of building. Ideal for use on corrugated siding due to narrow surface. 10 each (193-888)

### No. 5413 Adjustable Single Splice Bracket

Wall mount. A splice bracket with set screws to join and hold two lengths of rail together. 10 each (193-896)

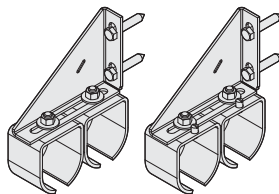

5414

5415

### No. 5414 Adjustable Double Bracket

Wall mount. Used at two-foot intervals to bring double runs of rail to side of building for by-pass installation. Ideal for use on corrugated siding due to narrow surface. 10 each (193-904)

### No. 5415 Adjustable Double Splice Bracket

Wall mount. A splice bracket with set screws to join and hold two double lengths of rail together. 2 each (193-912)

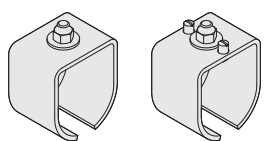

5418

5419

### No. 5418 Rail Bracket Only (No lag bolts)

Packed with bolt, nut and washer. 50 each (193-920)

### No. 5419 Rail Splice Bracket Only (No lag bolts)

Packed with bolt, nut and washer. 10 each (193-938)

## TrackMaster® Rail Applications

### By-Pass Installation

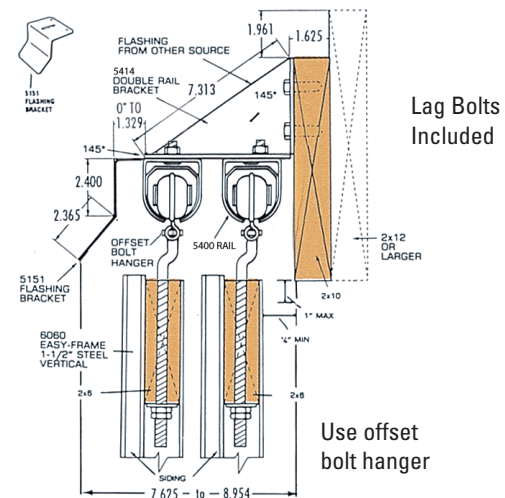

Lag Bolts Included

Use offset bolt hanger

FACE MOUNT

TOP MOUNT

BRACKET MOUNT

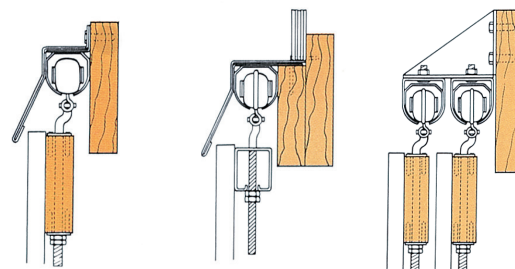

# TRACKMASTER® ROUND RAIL & ACCESSORIES

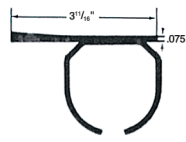

## No. 5433 Top Mount Rail

Welded-on top mount brackets (2 foot O.C.). For doors weighing up to 600 lbs. per panel. Fourteen gauge galvanized steel. Welded on mounting brackets for fast, easy installation. Just nail the rail to track board. If flashing is required, use our #5436, 5437 Snap-On Flashing Brackets. For 1 1/2" doors use our #5455 flashing and 5436 brackets. Rail in 8'-20' lengths.

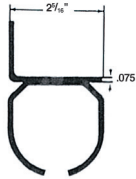

## No. 5430 Face Mount Rail

Welded-on face mount brackets (2 foot O.C.). For doors weighing up to 600 lbs. per panel. Fourteen gauge galvanized steel. Welded on mounting brackets for fast, easy installation. If flashing is required, use our Snap-On Flashing Brackets #5436 or 5437. For 1 1/2" doors use our #5450 flashing and 5436 bracket. Rail in 8'-20' lengths.

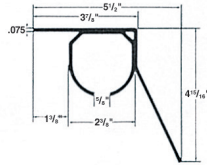

## No. 5460 Top Mount Rail with Attached Flashing Brackets

Welded-on top mounting brackets (2 foot O.C.). For doors weighing up to 600 lbs. per panel. Fourteen gauge galvanized steel. No. 5455 flashing fits easily over rail and bracket. Rail in 8'-20' lengths.

## Unique Snap-On Flashing Bracket For 1 1/2" or 3 1/2" thick doors.

Simplifies rail installation. Just attach rail to track board and "snap-on" flashing brackets—then add flashing.

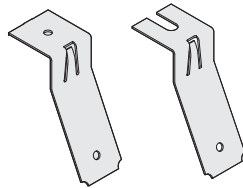

5436  
.075 Material Thickness

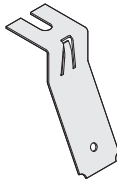

5436  
.075 Material Thickness

## No. 5436 1 1/2" Door Snap-On Flashing Bracket

Snaps-On 5430/5433 rails. For use with Nos. 5450/5455 flashing. Galvanized steel. 50 each (194-001)

## No. 5436 1 1/2" Door Snap-On Flashing Bracket - Custom Slot

Custom slot in the top of the bracket allows for installation with rail brackets bolted to a triangle or strap support. For use with 5450 flashing. 50 each (N340-752)

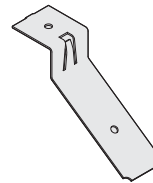

5437  
.075 Material Thickness

## No. 5437 3 1/2" Door Snap-On Flashing Bracket

Snaps-On 5430/5433 rails. Flashing from alternate source. Galvanized steel. 50 each (194-019)

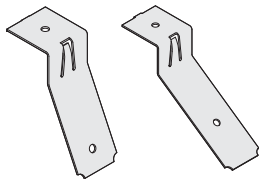

5438  
.075 Material Thickness

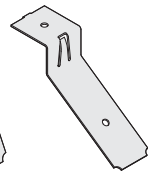

5439  
.075 Material Thickness

## No. 5438 1 1/2" Door Snap-on Flashing Brackets

For use with Nos. 5450/5455 flashing. Galvanized Steel. 25 each (N100-010)

## No. 5439 3 1/2" Snap-on Flashing Brackets

Designed to snap into plain rail brackets that have a square hole in the top. USE FLASHING FROM ANOTHER SOURCE. 25 each (100-011)

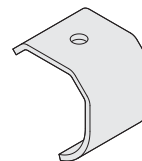

5405

## No. 5405 Splice Collar

Unique design supports the end of two rails while not interfering with flat mounting surface of rail. No fasteners required. Simply slide onto rail while installing. Use with #5430, 5433 and 5460 rails. 10 each (193-847).

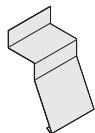

5450

## No. 5450 Face Mount Flashing

For 5430 rail and 5436 Flashing Brackets. Ten-foot sections. White finish. Twenty-eight gauge steel. 10 each (194-027) For 1 1/2" doors.

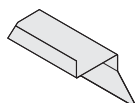

5455

## No. 5455 Top Mount Flashing

For 5433 rail and 5436 Flashing Brackets. Ten-foot sections. White finish. Twenty-eight gauge steel. 10 each (194-035) for 1 1/2" doors.



5408

## No. 5408 Rail End Cap

(No lag bolts.) Packed with bolt, nut and washer.

## Flexible Hangers with Hardened Steel Wheels

Hardened steel wheel hangers for doors weighing up to 600 lbs. All National TrackMaster™ hangers have corrosion-resistant, zinc-plated strong steel trucks and induction-hardened zinc-plated steel axles for longer life. Plus steel roller bearings of precision-ground hardened steel with sealed bearing chamber and advanced-design seal. This results in a longer lasting, easier rolling door system.

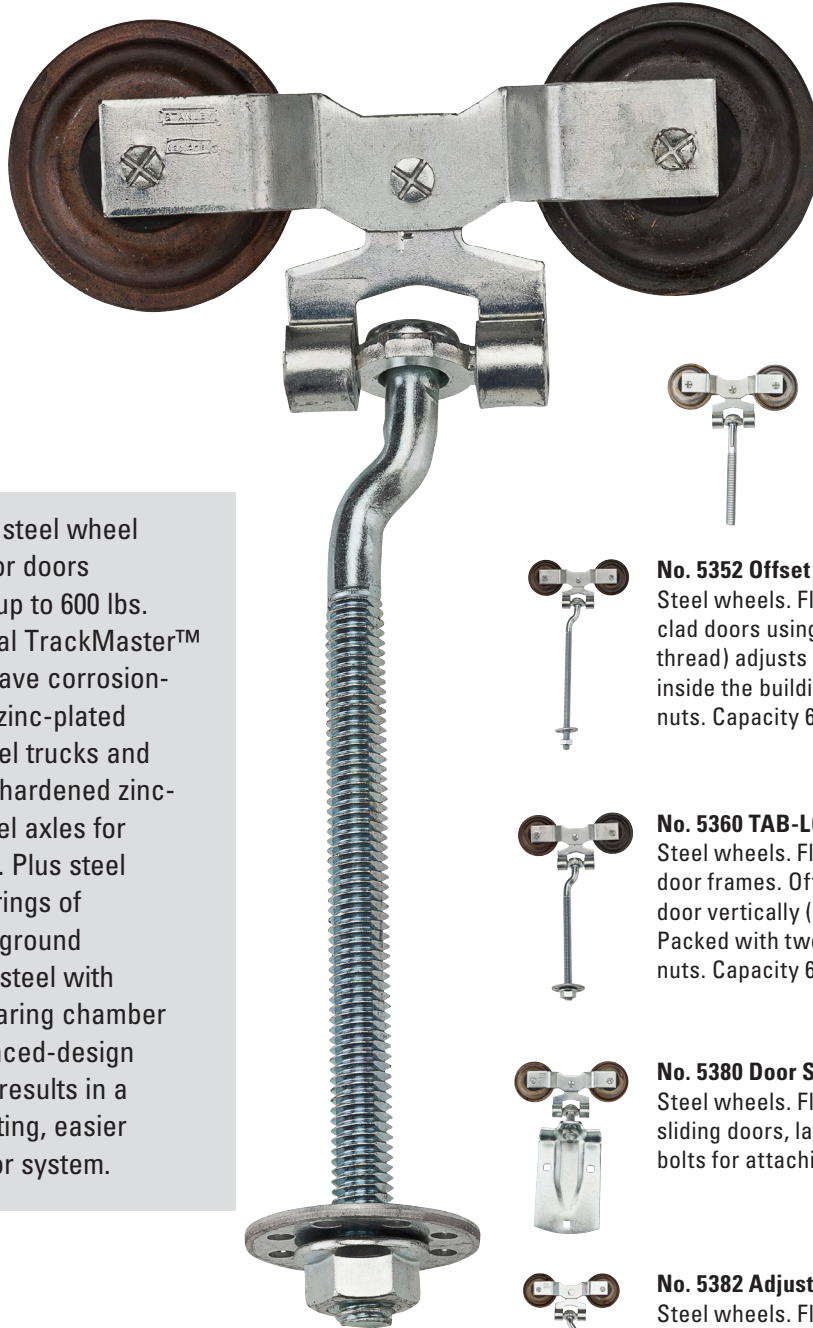

**No. 5350 Round Rail Trucks**  
Steel wheels. Flexible trunnion. Precision-ground and hardened steel roller bearings, axles and sleeves provide longer life and easier operation.



**No. 5351 Straight Bolt Hanger**  
Steel wheels. Flexible trunnion straight bolt with nuts 5" (193-649) bolt lengths. Capacity 600 lbs./pr.



**No. 5352 Offset Bolt Hanger**  
Steel wheels. Flexible trunnion. For wood frame metal-clad doors using a 2 x 6 top lateral. Offset 9" bolt (with 7" thread) adjusts door vertically (7") and laterally (1") from inside the building. Packed with four washers and four hex nuts. Capacity 600 lbs./pr. (193-656)



**No. 5360 TAB-LOC™ Hanger**  
Steel wheels. Flexible trunnion. For use with TAB-LOC steel door frames. Offset 7 1/2" bolt (with 5 1/2" thread) adjusts door vertically (5 1/2") and laterally (1") from inside the door. Packed with two star washers, two hex nuts, two flange nuts. Capacity 600 lbs./pr. (193-664)



**No. 5380 Door Strap Hanger**  
Steel wheels. Flexible trunnion hanger for use on wood frame sliding doors, laterally and vertically adjustable. Packed with bolts for attaching door straps. Capacity 600 lbs./pr. (193-672)



**No. 5382 Adjustable Door Strap Hanger**  
Steel wheels. Flexible trunnion hanger for use on wood frame sliding doors. Hanger has 7 1/2" offset bolt with (2 1/2") vertical and (1") lateral adjustments that can be made from outside the building. Packed with bolts for attaching door straps. Capacity 600 lbs./pr. (193-680)

# TRACKMASTER® ROUND RAIL & ACCESSORIES

## Flexible Hangers with Delrin® Wheels

Durable Delrin® wheel hangers with steel bearings are strong, quiet and easy rolling. All National TrackMaster hangers have corrosion-resistant, zinc-plated strong steel trucks and induction-hardened, zinc-plated steel axles for longer life. Bearings of precision-ground hardened steel with sealed bearing chambers and advanced design seal for easy, quiet rolling. Capacity 600 lbs./pr.

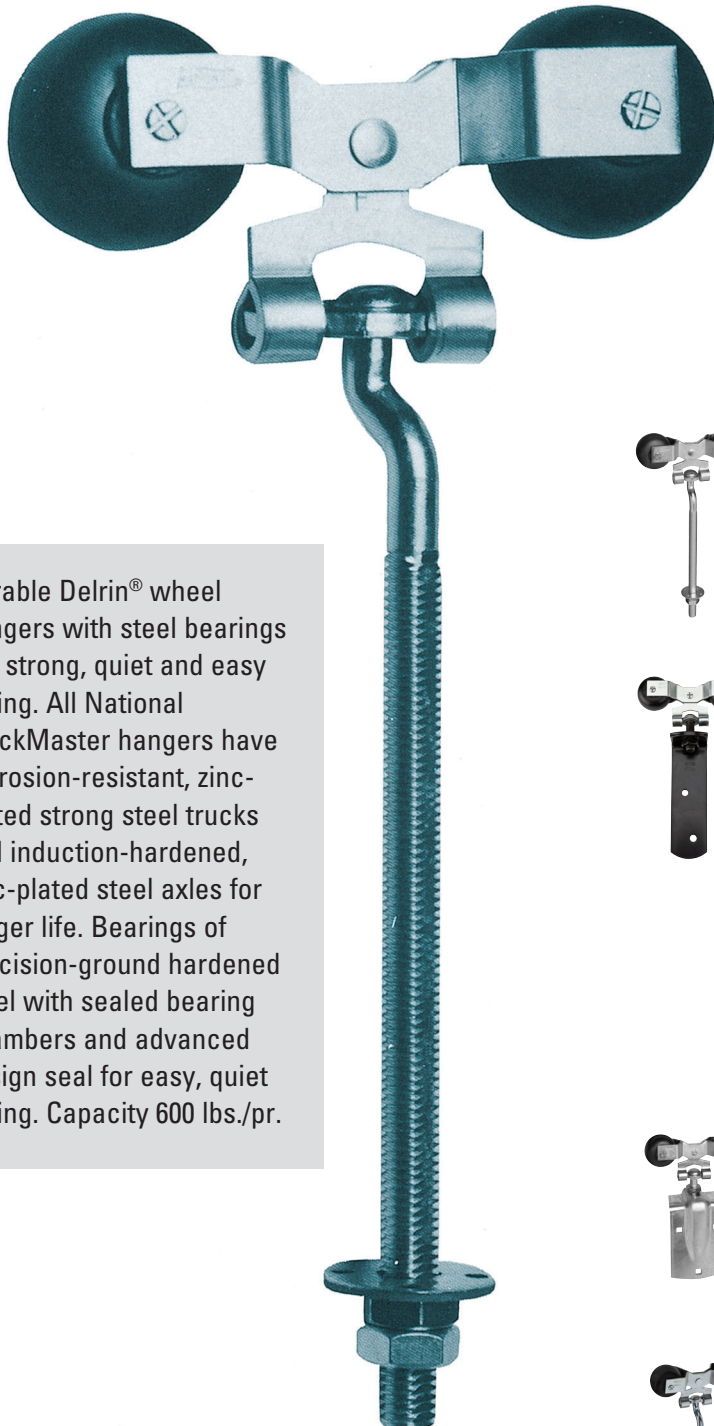

### 5300 Round Rail Trucks

Delrin wheels. Flexible trunnion. Precision-ground and hardened steel roller bearings, axles and sleeves provide longer life and easier operation.



### No. 5301 Straight Bolt Hanger

Delrin® wheels. Flexible trunnion straight bolt with nuts 31/8" (193-698) or 5" (193-706) bolt lengths. Capacity 600 lbs./pr.



### No. 5302 Offset Bolt Hanger

Delrin® wheels. Flexible trunnion. For wood frame metal clad doors using a 2 x 6 top lateral. Offset 9" bolt (with 7" thread) adjusts door vertically (7") and laterally (1") from inside the building. Packed with four washers and four hex nuts. Capacity 600 lbs. (193-714)



### No. 5306 With Heavy Single Door Strap

Delrin® wheels. Flexible trunnion for use on wood frame doors. Satin black finish. (208-504)

### No. 5310 TAB-LOC™ Hanger

Delrin® wheels. Flexible trunnion. For use with TAB-LOC™ steel door frames. Offset 71/2" bolt (with 51/2" thread) adjusts door vertically (51/2") and laterally (1") from inside the building. Packed with two star washers, two hex nuts, two flange nuts. Capacity 600 lbs./pr. (193-722)



### No. 5330 Door Strap Hanger

Delrin® wheels. Flexible trunnion hanger for use on wood frame sliding doors. Laterally and vertically adjustable. Packed with bolts for attaching door straps. Capacity 600 lbs./pr. (193-730)



### No. 5332 Adjustable Door Strap Hanger

Delrin® wheels. Flexible trunnion hanger for use on wood frame sliding doors. Hanger has 71/2" offset bolt with (21/2)" vertical and (1)" lateral adjustments that can be made from outside the building. Packed with bolts for attaching door straps. Capacity 600 lbs./pr. (193-748)

