

DOOR DETAIL

OUTSIDE

INSIDE

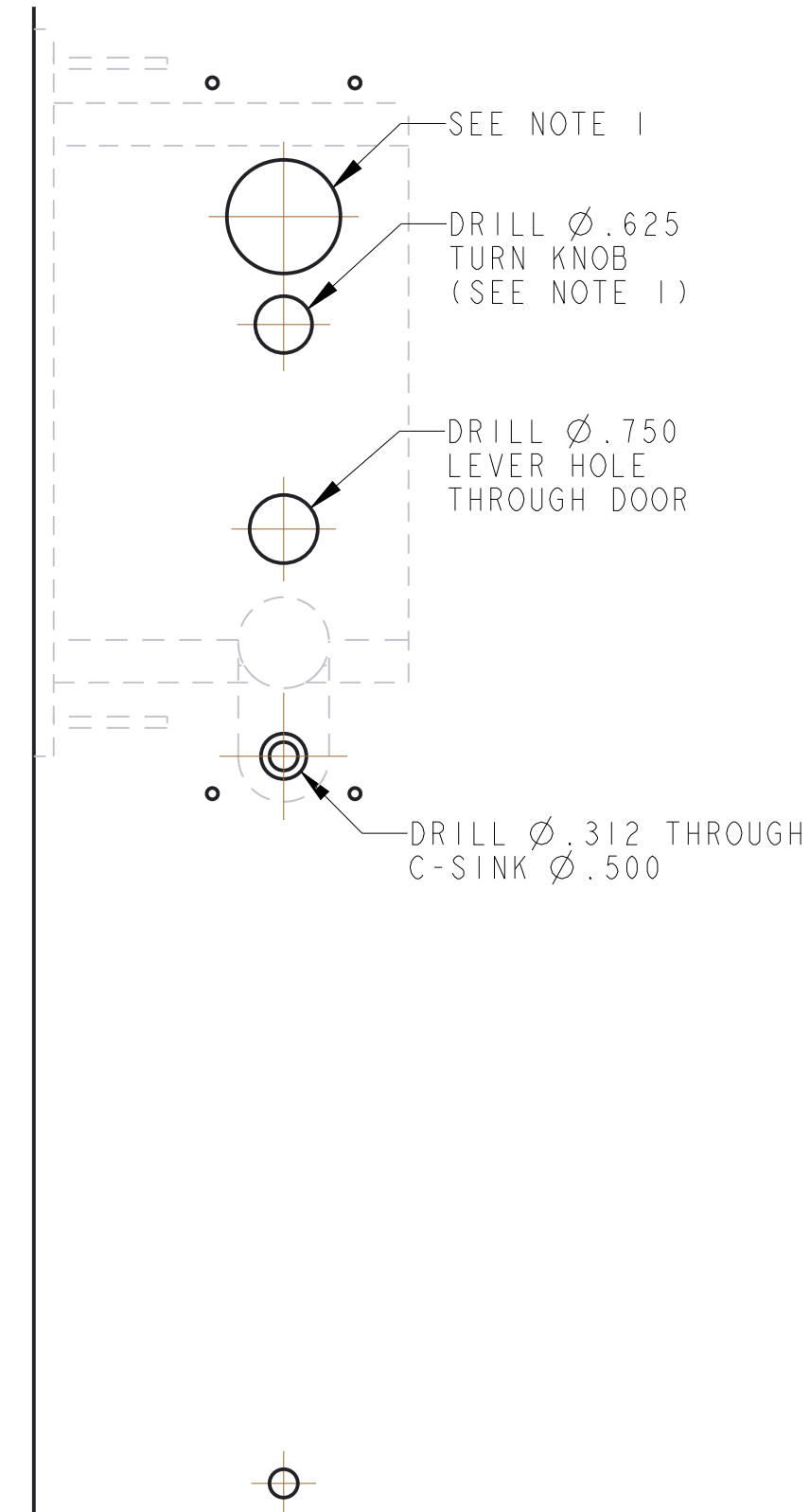
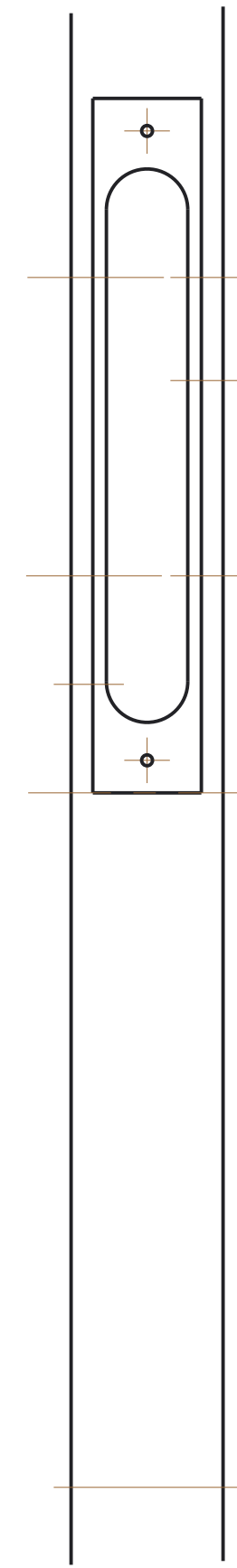
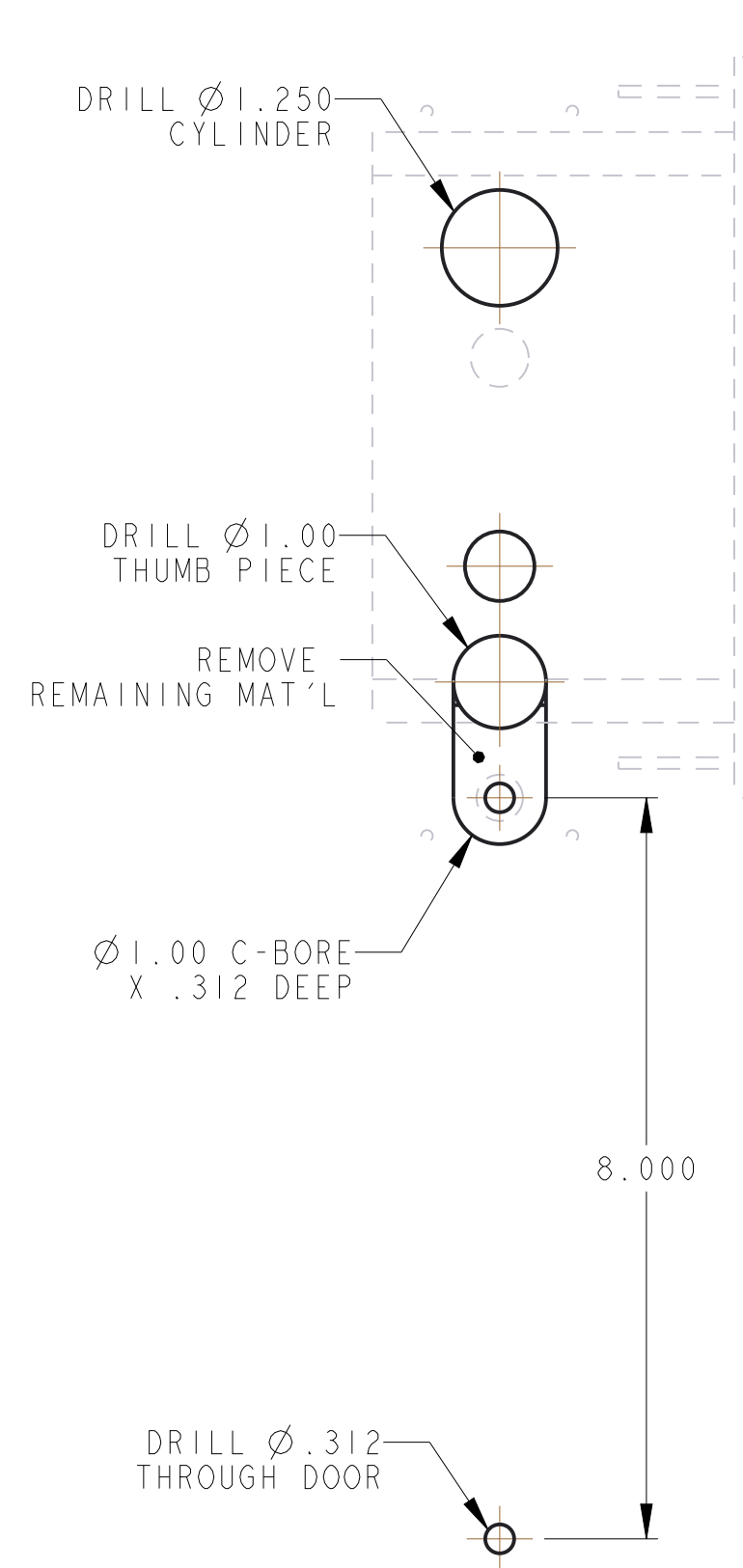

- NOTE:
1. WHEN PREPARING DOOR FOR DOUBLE CYLINDER FUNCTION, OMIT DRILLING OF Ø.625 TURN KNOB HOLE (INSIDE). INSTEAD DRILL Ø1.250 CYLINDER HOLE USING SAME CENTER LINE AS OUTSIDE CYLINDER HOLE.
 2. FOR ADDITIONAL LOCK AND DOOR CUTOUT DIMENSIONS, SEE APPROPRIATE LOCK TEMPLATE.
 3. DRILL ALL HOLES HALF WAY THROUGH DOOR UNLESS OTHERWISE SPECIFIED.
 4. INSTALLATION PLATES ARE NOT REQUIRED FOR THIS TRIM.

TRIM DETAIL

RIGHT HAND ILLUSTRATED

OUTSIDE

INSIDE

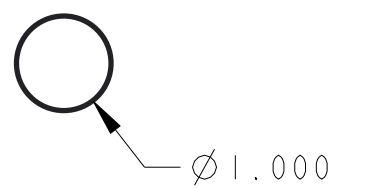
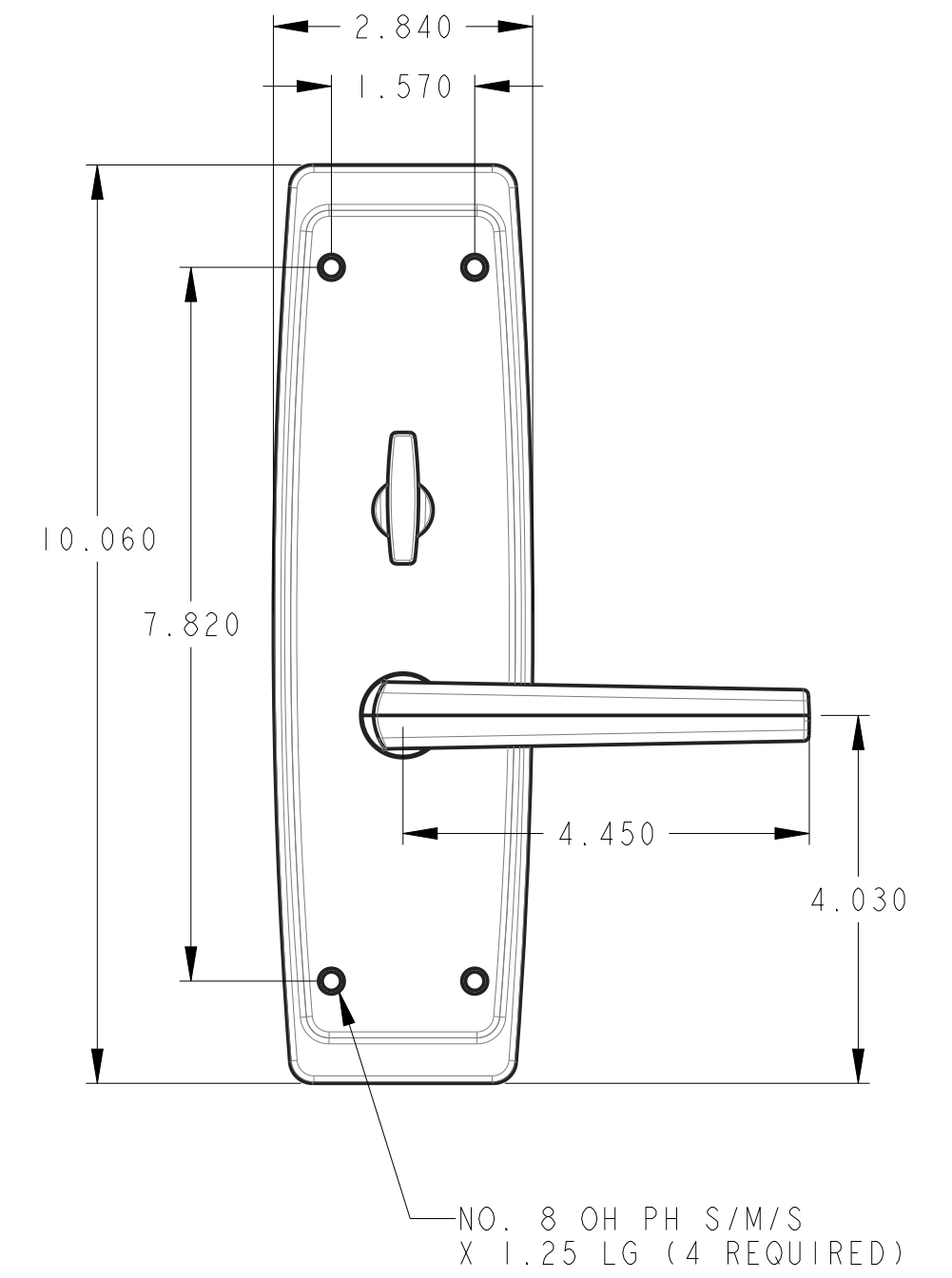
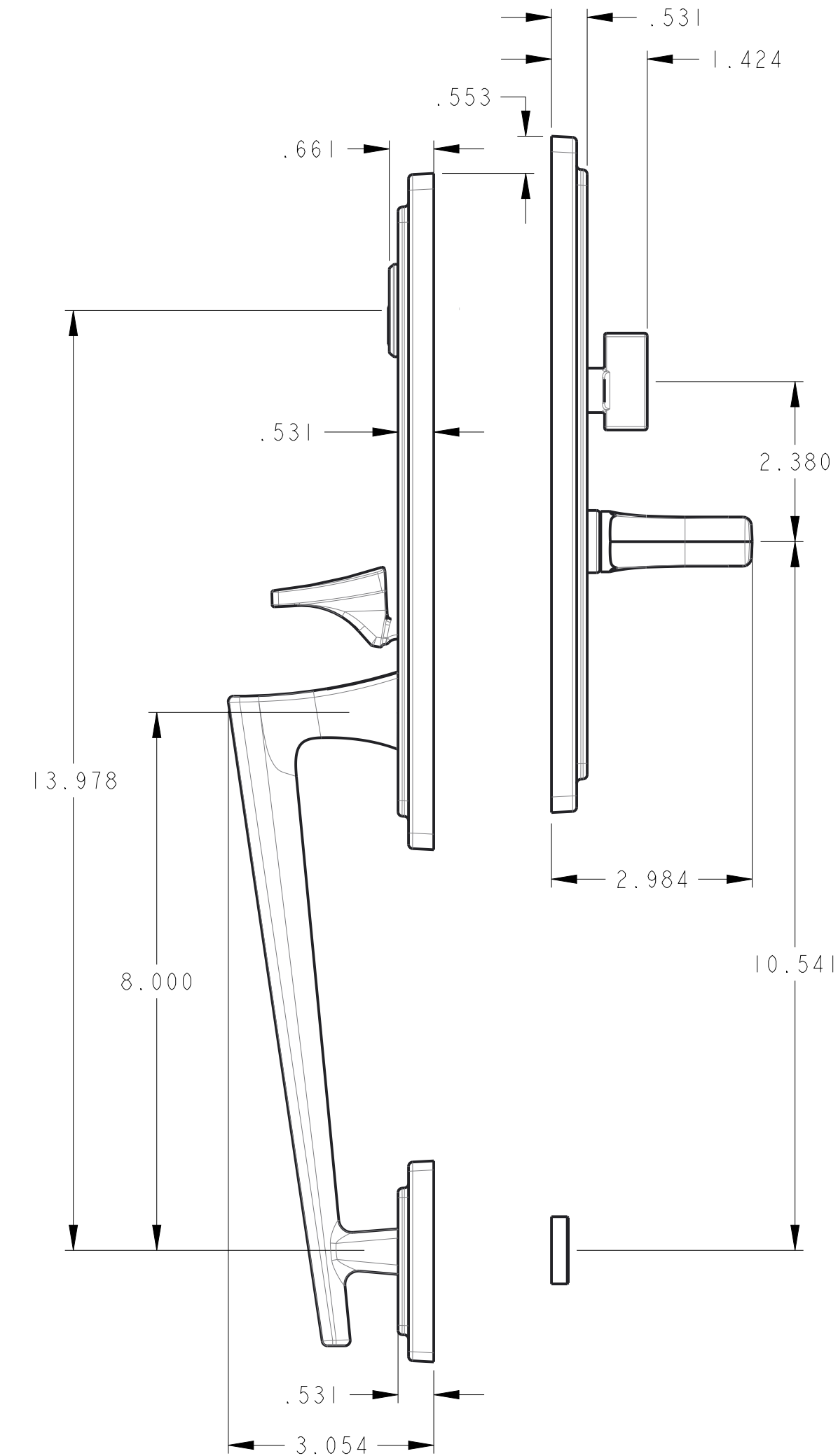
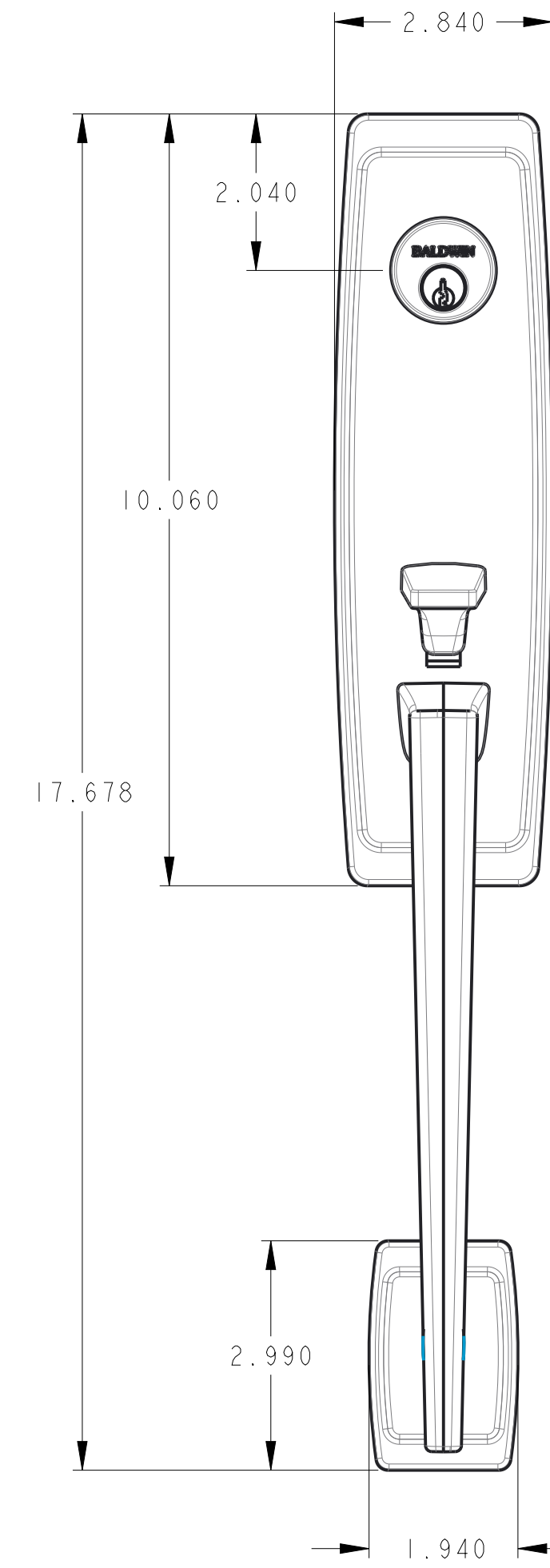

BALDWIN Spectrum Brands Hardware & Home Improvement		THIS DOCUMENT IS THE PROPERTY OF SPECTRUM BRANDS. IT AND ITS CONTENTS ARE UNCLASSIFIED AND NOT TO BE RELEASED OR DISSEMINATED TO ANY OTHER PERSON OR ENTITY WITHOUT THE EXPRESS WRITTEN PERMISSION OF SPECTRUM BRANDS. ANY UNAUTHORIZED REPRODUCTION, COPIES, OR PUBLISHED CONTENT OF SPECTRUM BRANDS' TRADE INFORMATION IS PROHIBITED.	
TITLE 6920 PALM SPRINGS 3/4 TRIM		SIZE D	DWG NO. P12265-9
SCALE 1 / 1		RELEASE STATE Preliminary	REV A
SHEET 9 OF 10		ITER 1	