

DOOR DETAIL

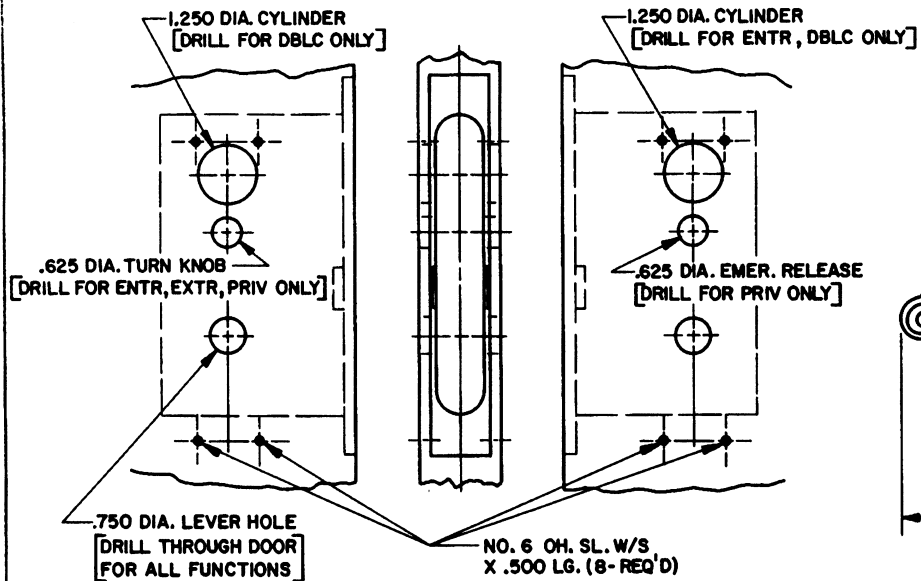

INSIDE

OUTSIDE

NOTE:

- 1.) FOR ADDITIONAL LOCK AND DOOR CUTOUT DIMENSIONS, SEE APPROPRIATE LOCK TEMPLATE.
- 2.) DRILL ALL HOLES HALFWAY THROUGH DOOR UNLESS OTHERWISE SPECIFIED.
- 3.) TO ENABLE EMERGENCY TRIM TO FUNCTION, THE TURN PIECE SPINDLE MUST BE CUT TO EXTEND NO FURTHER THAN HALF WAY THROUGH THE LOCK.
- 4.) INSTALLATION PLATES ARE NOT REQUIRED FOR THIS TRIM.

TRIM DETAIL (ENTR FUNCTION ILLUSTRATED)

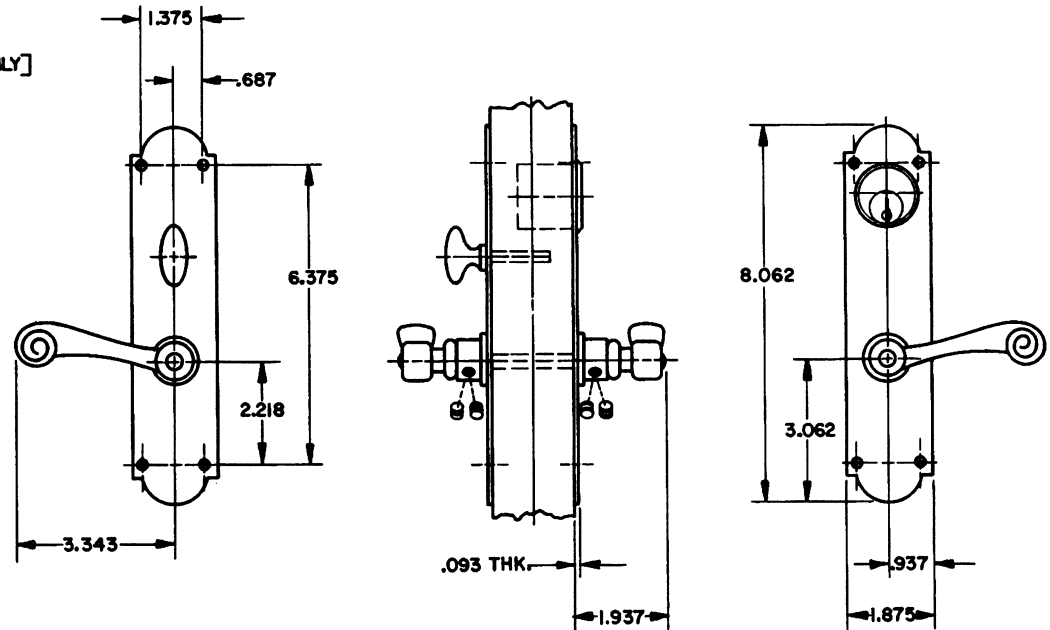

EFFECTIVE: 9-1-86 R.A.A-g

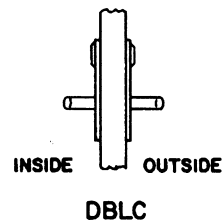
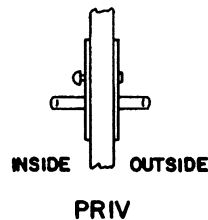
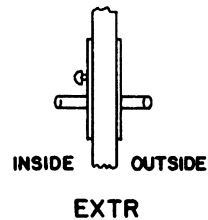
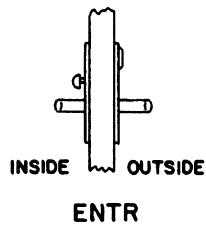

DO NOT SCALE DRAWING

BALDWIN	
6924 VANCOUVER TRIM	
TEMPLATE NO. VARIATIONS	TEMPLATE NO.
	1079

©1986 by Baldwin Hardware Corporation