

DOOR DETAIL

SEE NOTE NO. 1

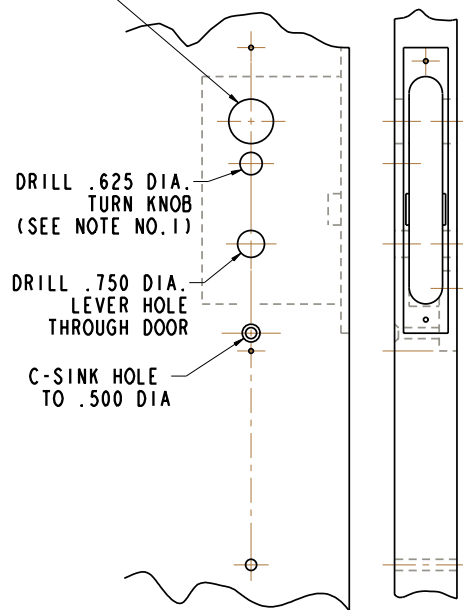

INSIDE

NO. 8-18 OH SL S/M/S X .750 LG (2 REQUIRED)

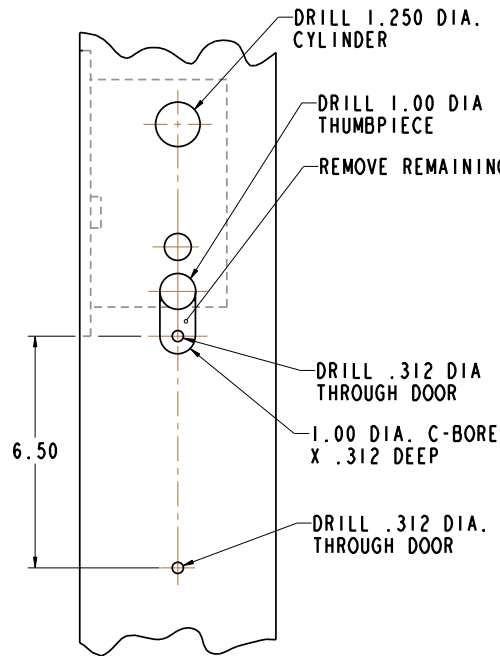

OUTSIDE

TRIM DETAIL

(RENT FUNCTION ILLUSTRATED)

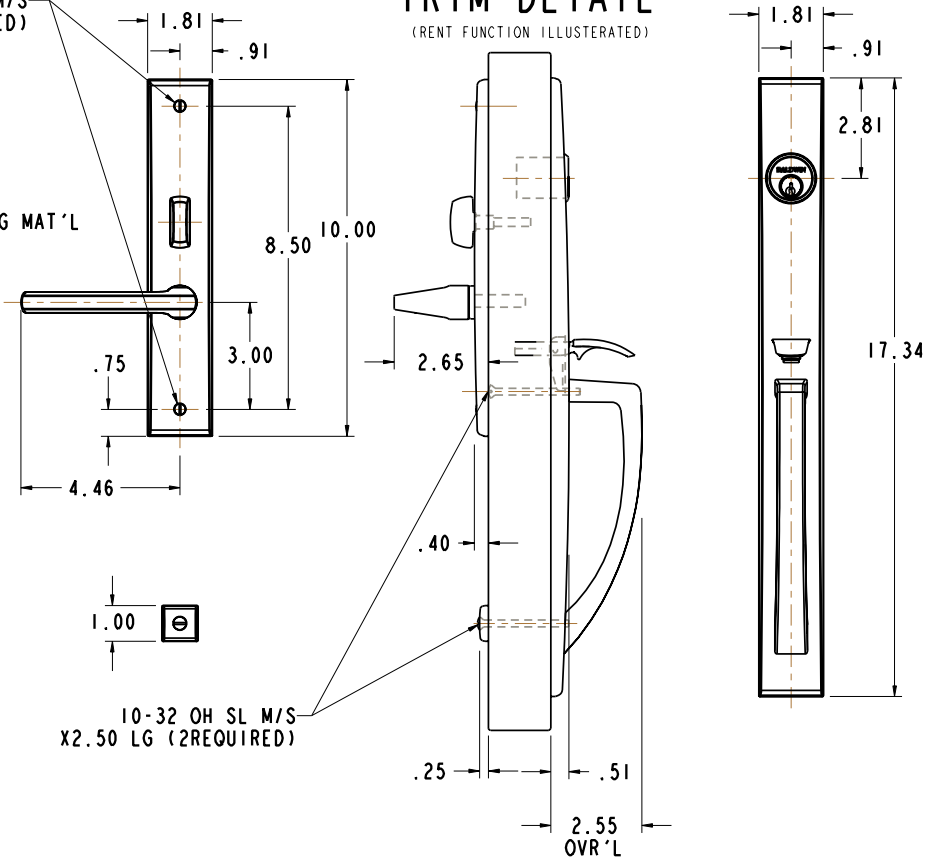

NOTE:

- 1) WHEN PREPARING DOOR FOR $\frac{L}{R}$ DBL FUNCTION, OMIT DRILLING OF $\varnothing .625$ TURN KNOB HOLE (INSIDE). DRILL A $\varnothing 1.250$ CYLINDER HOLE INSTEAD, USING SAME CENTER LINE AS OUTSIDE CYLINDER HOLE.
- 2) FOR ADDITIONAL LOCK AND DOOR CUTOUT DIMENSIONS, SEE APPROPRIATE LOCK TEMPLATE.
- 3) DRILL ALL HOLES HALF WAY THROUGH DOOR UNLESS OTHERWISE SPECIFIED.
- 4) INSTALLATION PLATES ARE NOT REQUIRED FOR THIS TRIM.

<p>BALDWIN HARDWARE CORPORATION READING, PENNSYLVANIA</p>	<p>A BLACK & DECKER COMPANY</p>
	<p>6966 LAKESHORE TRIM</p>
<p>TEMPLATE: NO VARIATIONS</p>	<p>TEMPLATE NO.</p>
<p>© 2006 BY BALDWIN HARDWARE CORPORATION</p>	<p>I-082</p>

DO NOT SCALE DRAWING

EFFECTIVE 01/01/07