

NOTES: UNLESS OTHERWISE SPECIFIED

REV	DESCRIPTION	DATE	DRAFTER	ENGINEER	APPROVED BY
1	PRODUCTION RELEASE PER E011833-47	01/16/18	E.XIN	D.YIP	JA.LIN

TUBULAR HANDLE SETS

TRIM	ITEM #	STYLE	PAGE
HOLLYWOOD HILLS	85310	SECTIONAL	2
HOLLYWOOD HILLS	85311	FULL	3

MORTISE HANDLE SETS

TRIM	ITEM #	STYLE	PAGE
HOLLYWOOD HILLS	6946	FULL	4
HOLLYWOOD HILLS	6945	KNB X KNB	5

DEADBOLT SETS

TRIM	ITEM #	STYLE	PAGE
HOLLYWOOD HILLS	8260	SINGLE CYLINDER	6
HOLLYWOOD HILLS	8261	DOUBLE CYLINDER	7



THIS DOCUMENT IS THE PROPERTY OF SPECTRUM BRANDS, INC. AND/OR ITS AFFILIATES. THE CONTENTS OF THIS DOCUMENT ARE CONFIDENTIAL AND CONSTITUTE TRADE SECRETS PROPRIETARY TO SPECTRUM BRANDS. NEITHER THIS DOCUMENT NOR ITS CONTENTS SHALL BE DISCLOSED TO ANY UNAUTHORIZED PERSON, COPIED, OR PUBLISHED WITHOUT SPECTRUM BRANDS' PRIOR WRITTEN CONSENT.

DRAFTER	D.YIP	DATE	08/31/16	SPECTRUM BRANDS, INC. HARDWARE AND HOME IMPROVEMENT 19701 DA VINCI, LAKE FOREST, CA 92610 TITLE H HILLS PRODUCT TEMPLATE
CHECKED	JA.LIN	DATE	08/31/16	
ENGINEER	D.YIP	DATE	08/31/16	
APPROVED	JA.LIN	DATE	08/31/16	
THIRD ANGLE PROJECTION 				SIZE D DO NOT SCALE DRAWING RELEASE STATE Production
DWG NO P12388				SHEET 1 OF 7

DOOR DETAIL

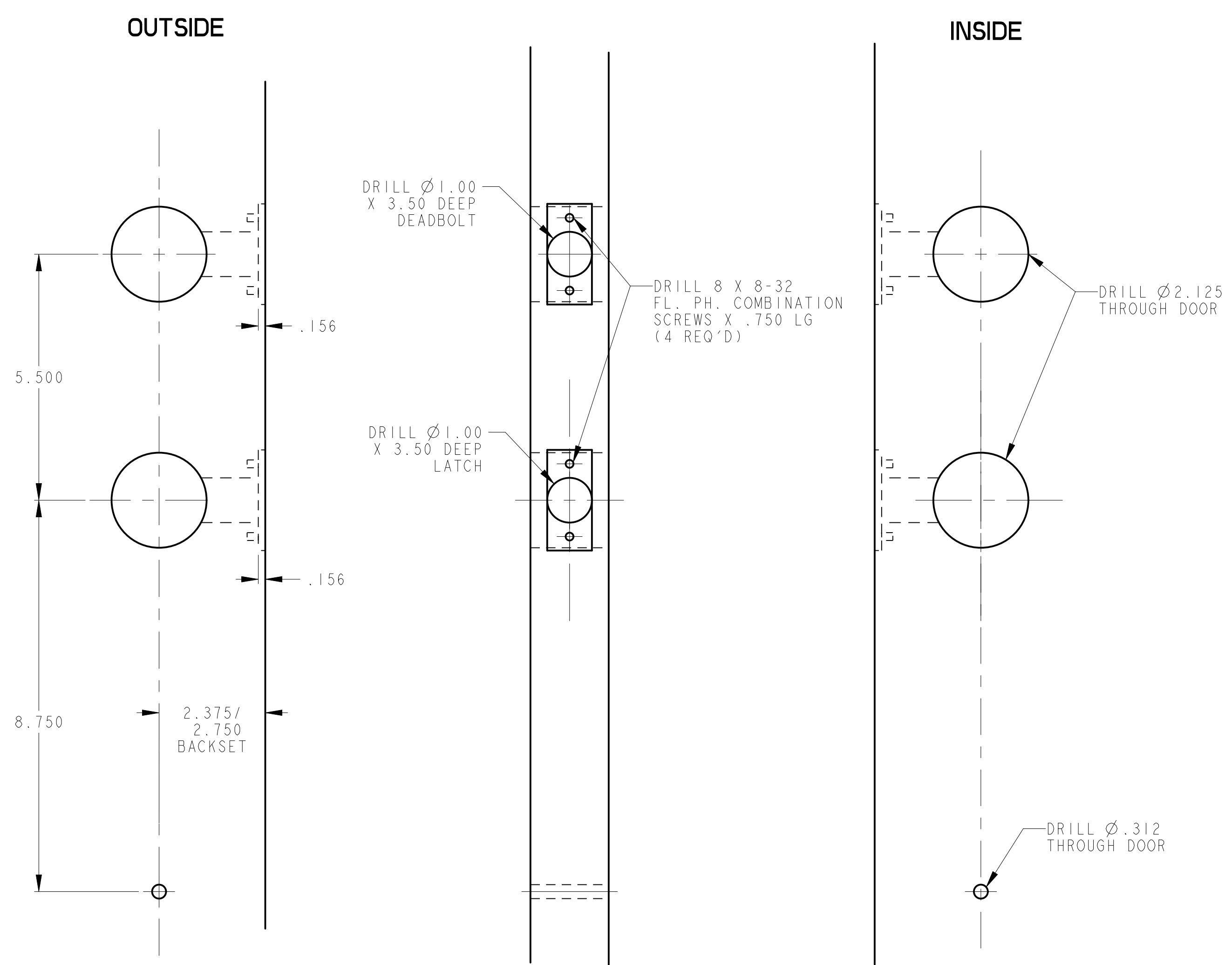

TRIM DETAIL

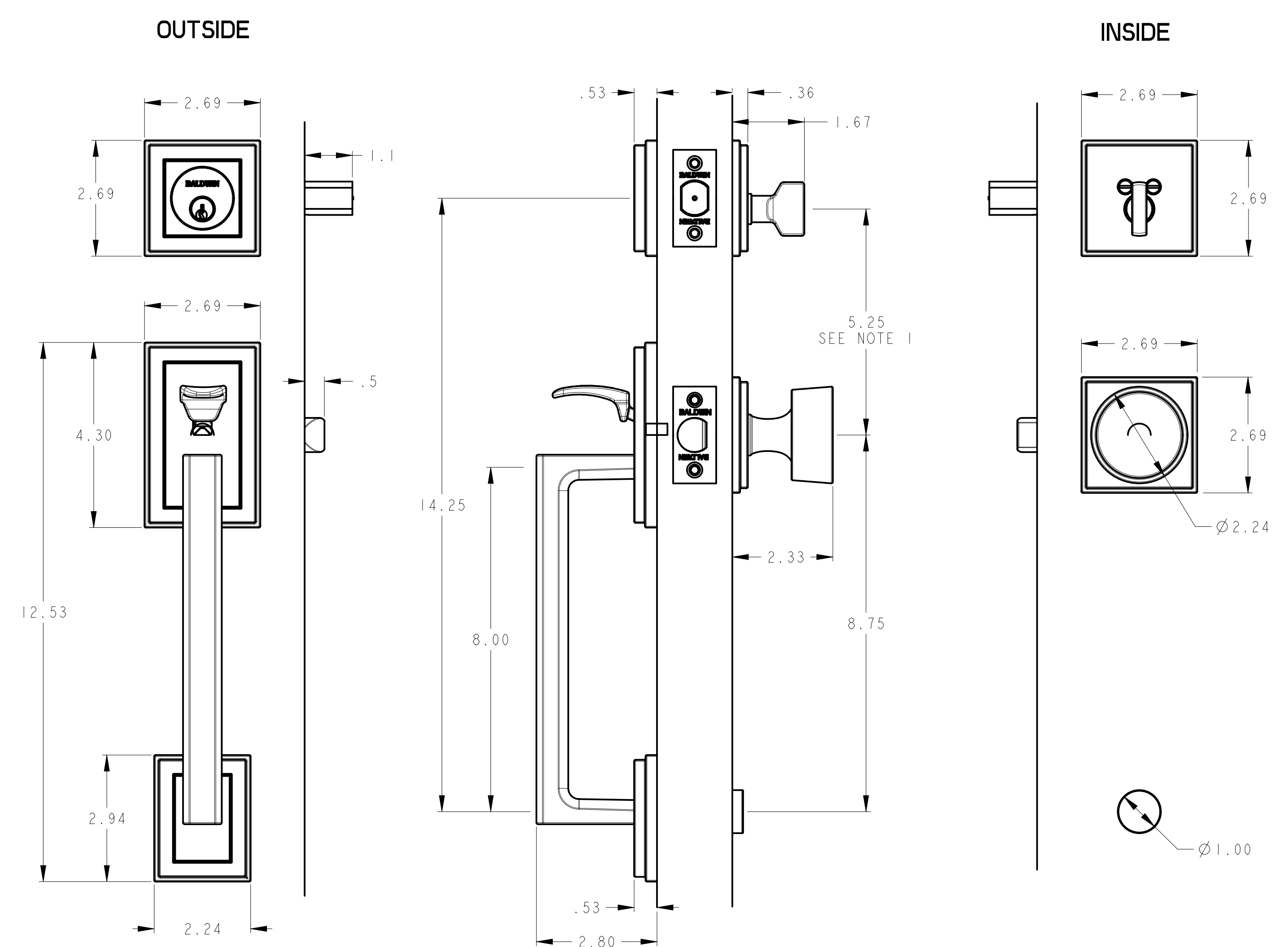

NOTE:
 1. TURN KNOB IS NOT CONCENTRIC TO $\varnothing 2.125$ BORE HOLE.

DEADBOLT STRIKE

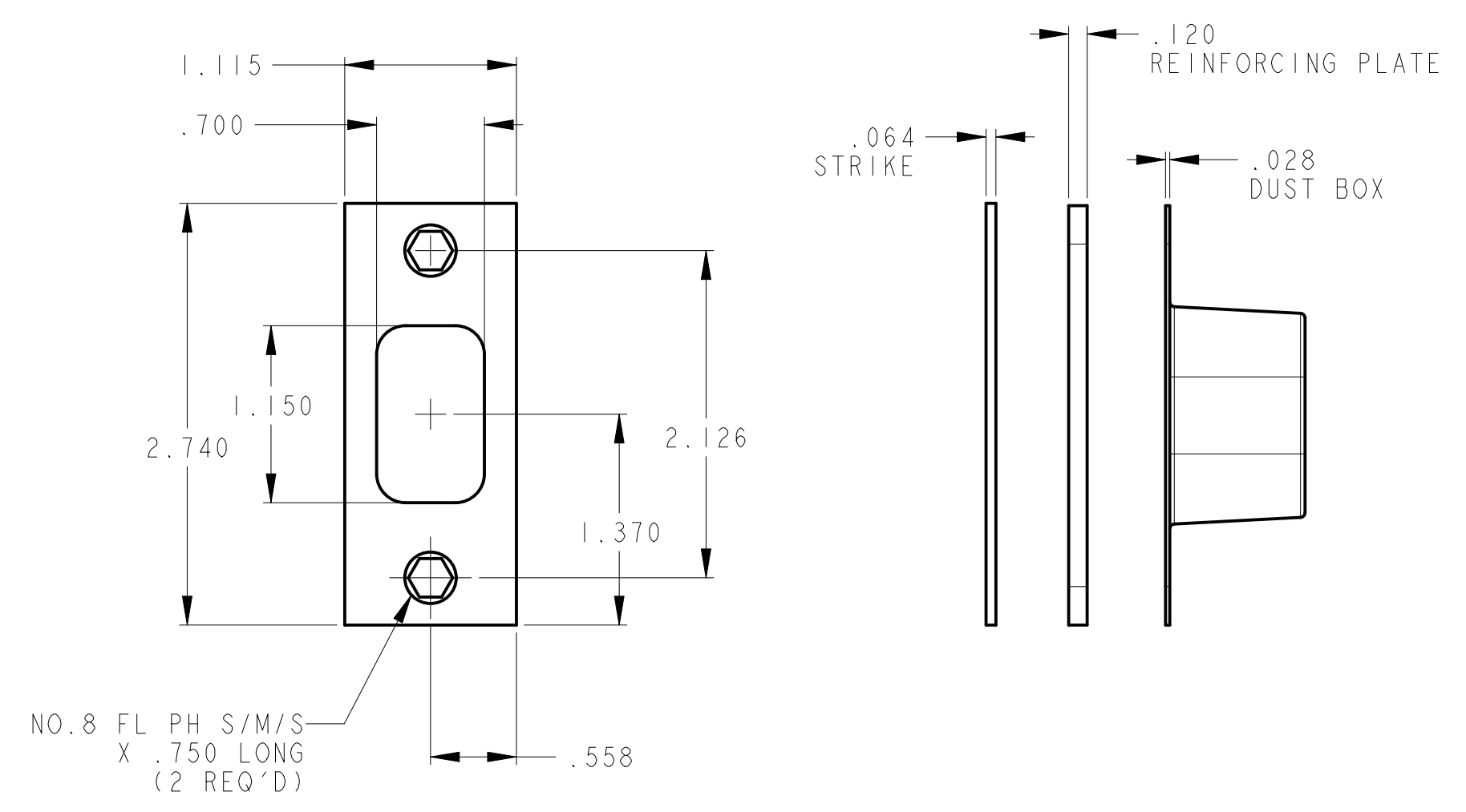

LATCH STRIKE

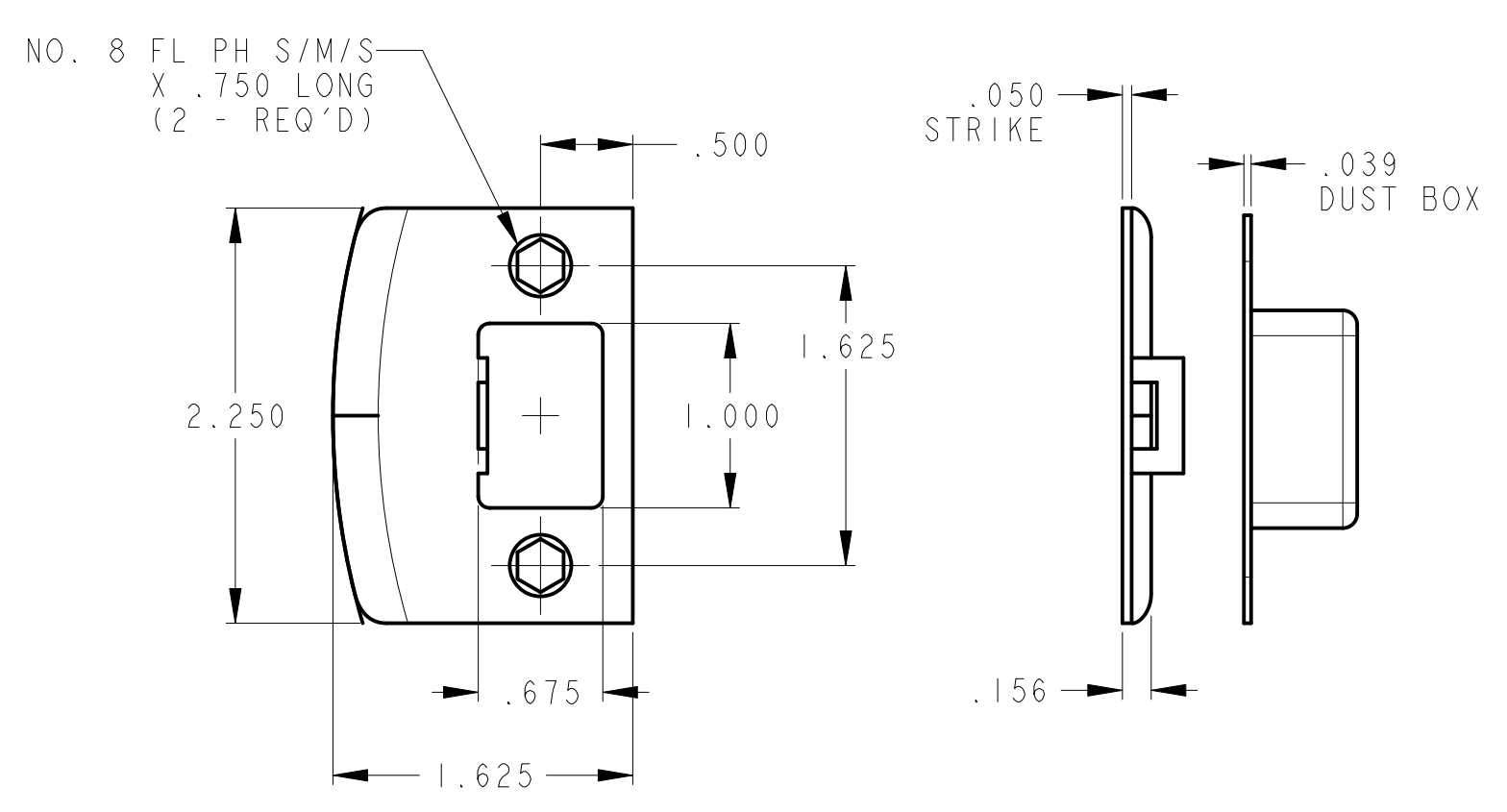

BALDWIN		THIS DOCUMENT IS THE PROPERTY OF SPECTRUM BRANDS. IT AND ITS CONTENTS ARE UNCLASSIFIED AND FOR OFFICIAL USE ONLY. IT IS TO BE CONTAINED AND CONTROLLED AS SUCH. IT IS TO BE RELEASED TO THE PUBLIC ONLY BY THE ISSUING OFFICE. UNAUTHORIZED REPRODUCTION, COPIES, OR DISSEMINATION OF THIS DOCUMENT IS PROHIBITED. SPECTRUM BRANDS, TRADE MARKS, AND LOGOS ARE THE PROPERTY OF SPECTRUM BRANDS. © 2014 SPECTRUM BRANDS. ALL RIGHTS RESERVED.	
Spectrum Brands Hardware & Home Improvement		TITLE: 85310 HOLLYWOOD HILLS SECT HS	
SIZE: D	DO NOT SCALE DRAWING	DWG NO: P12388	REV: 1
SCALE: 1/2	RELEASE STATE: Production	TITER: 0	SHEET: 2 OF 7

REV	DESCRIPTION
1	SEE SHEET 1

DOOR DETAIL

TRIM DETAIL

OUTSIDE

INSIDE

OUTSIDE

INSIDE

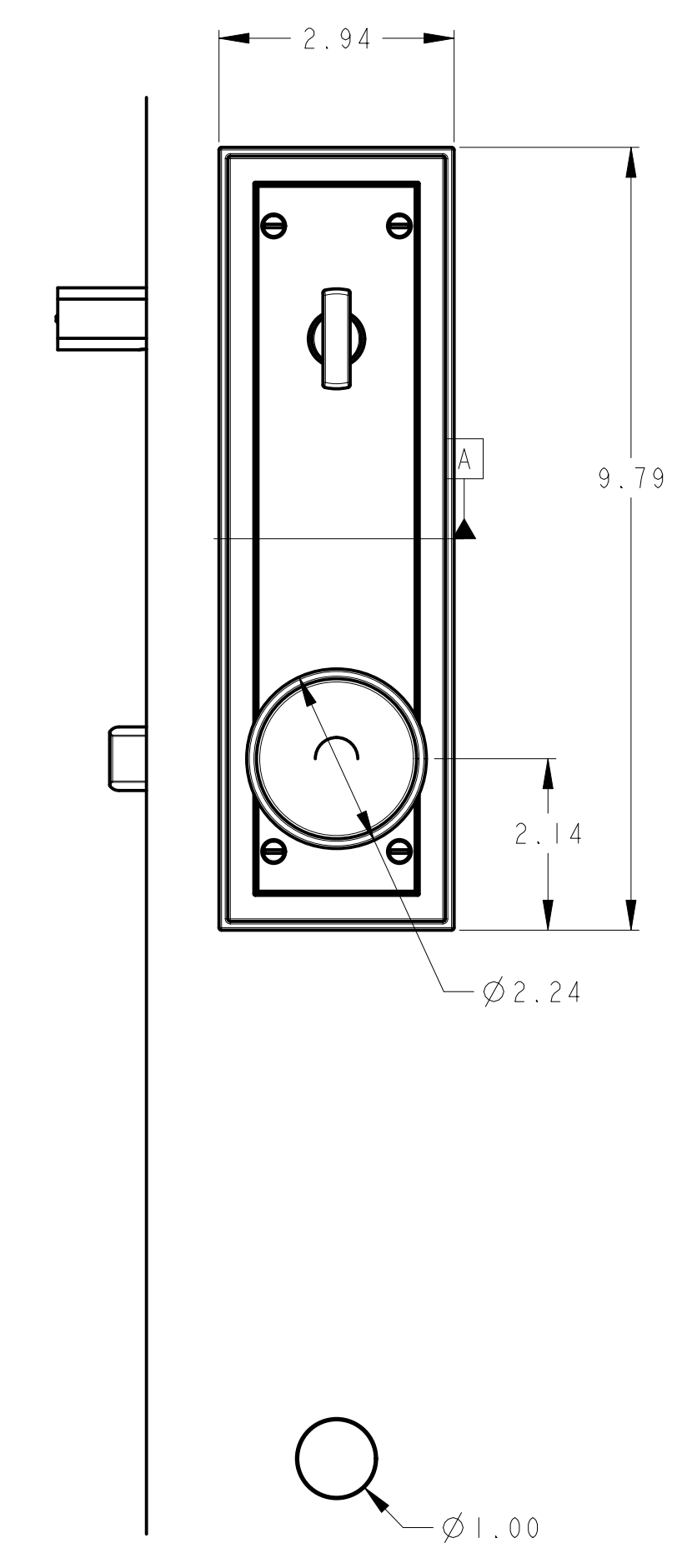
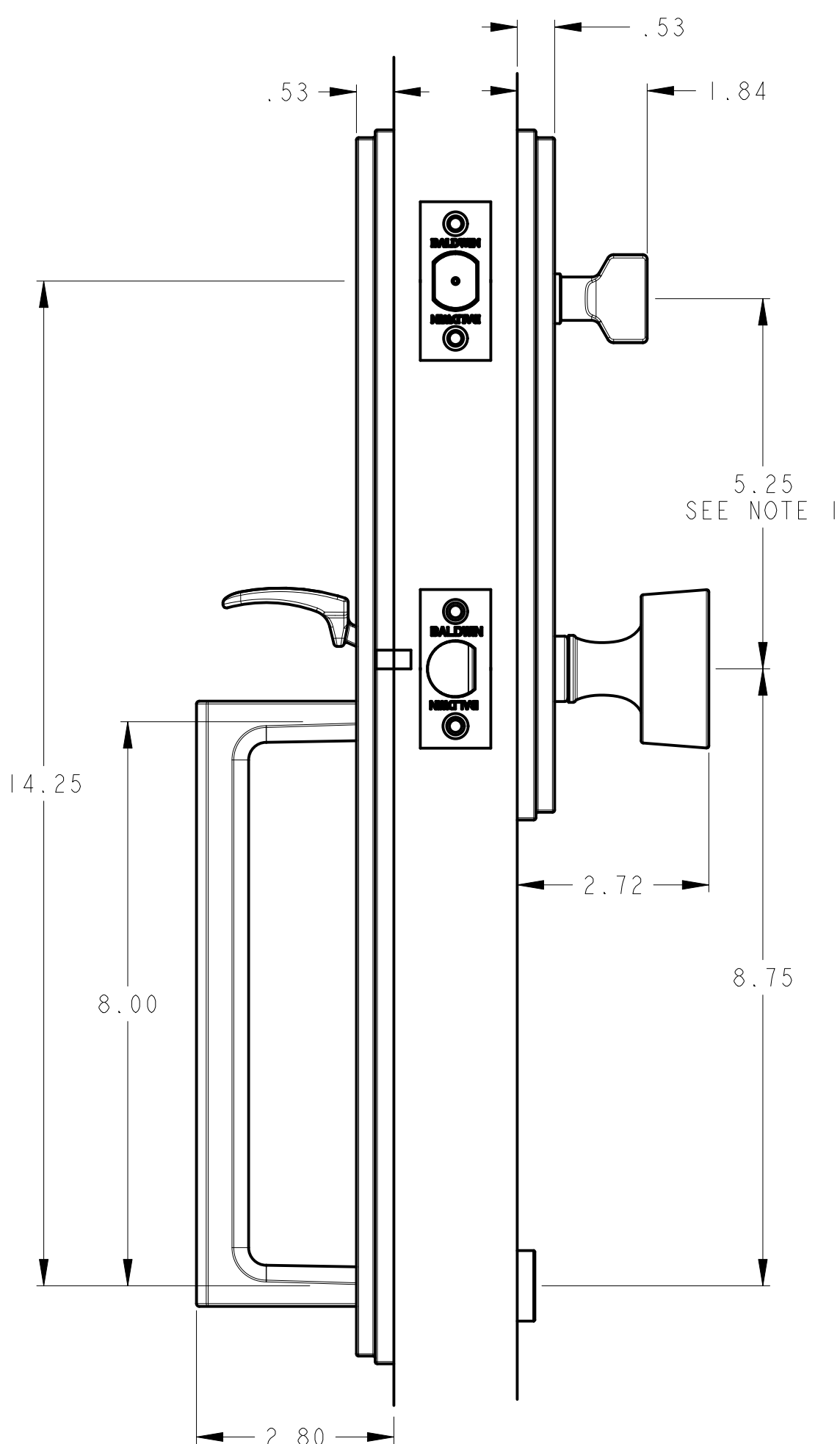
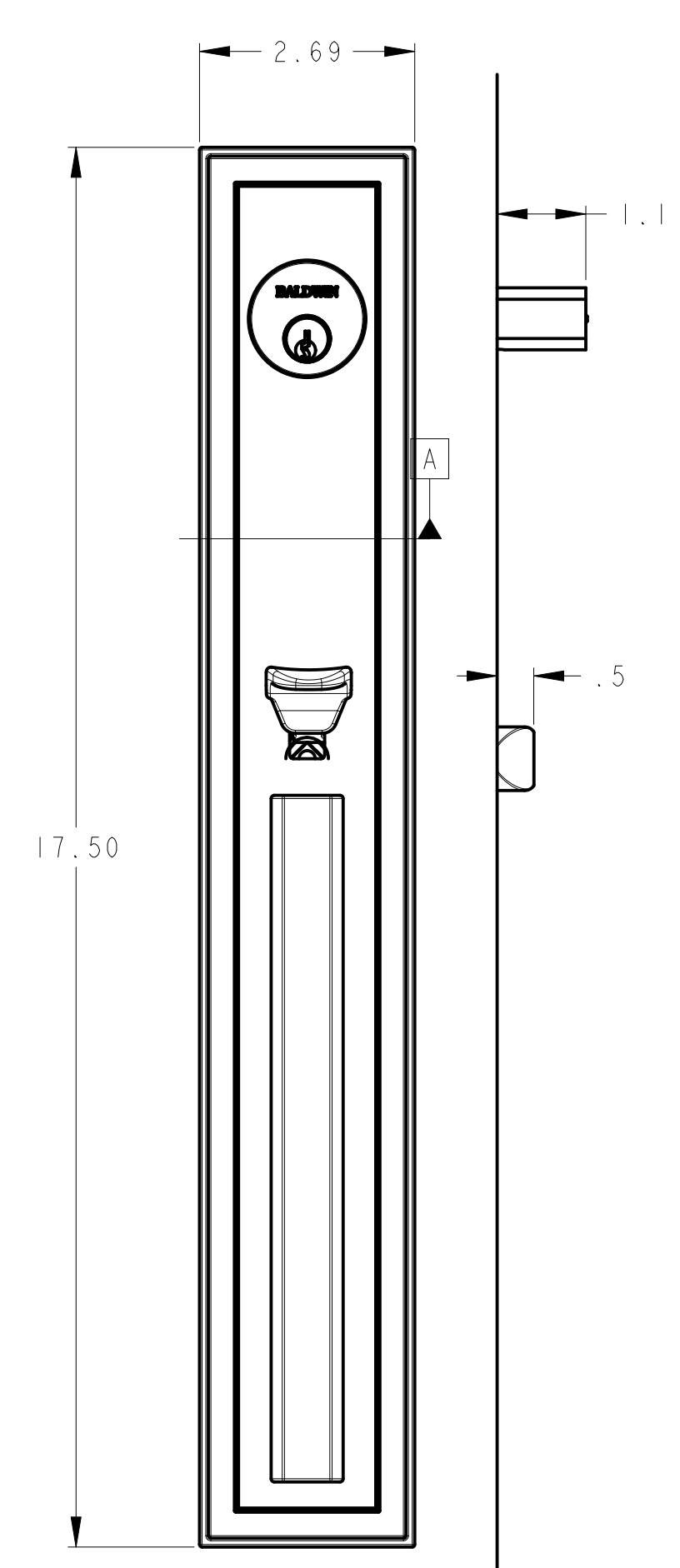
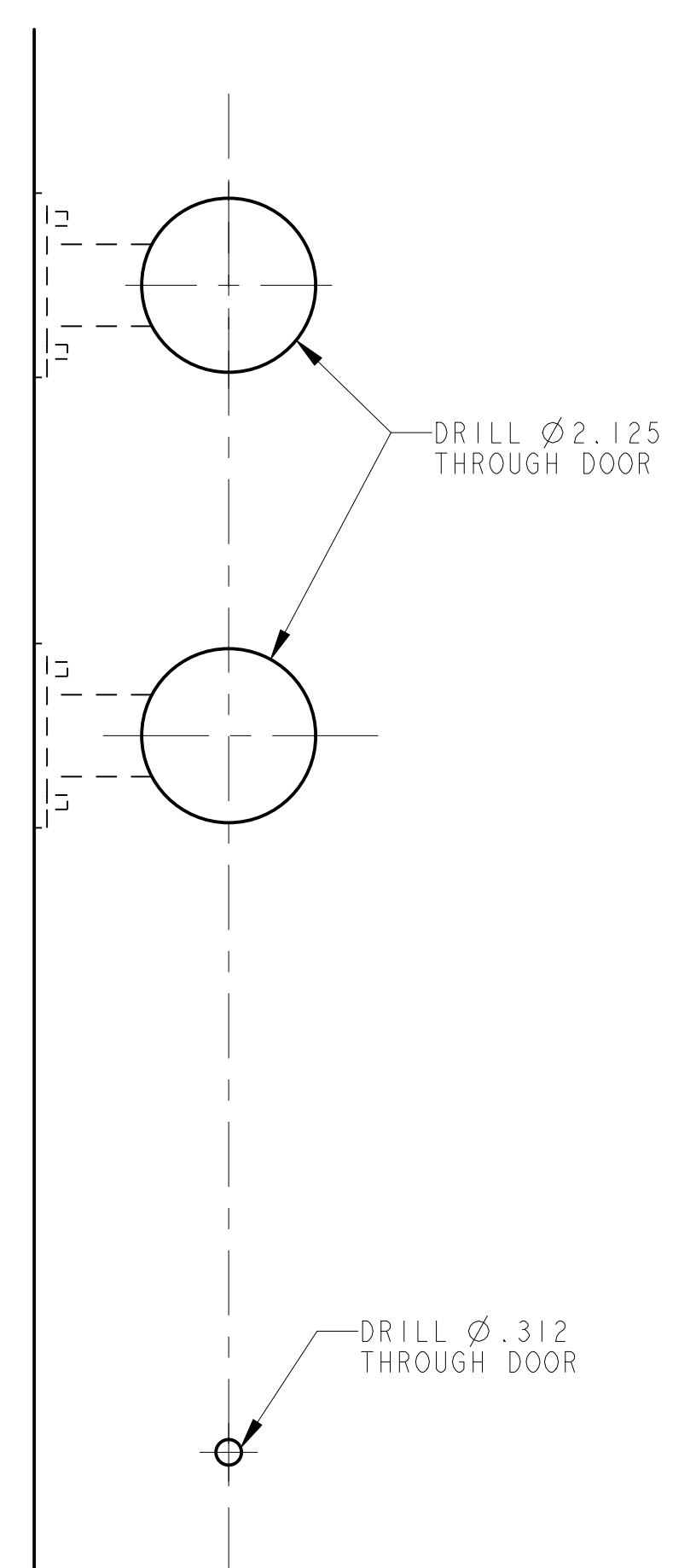
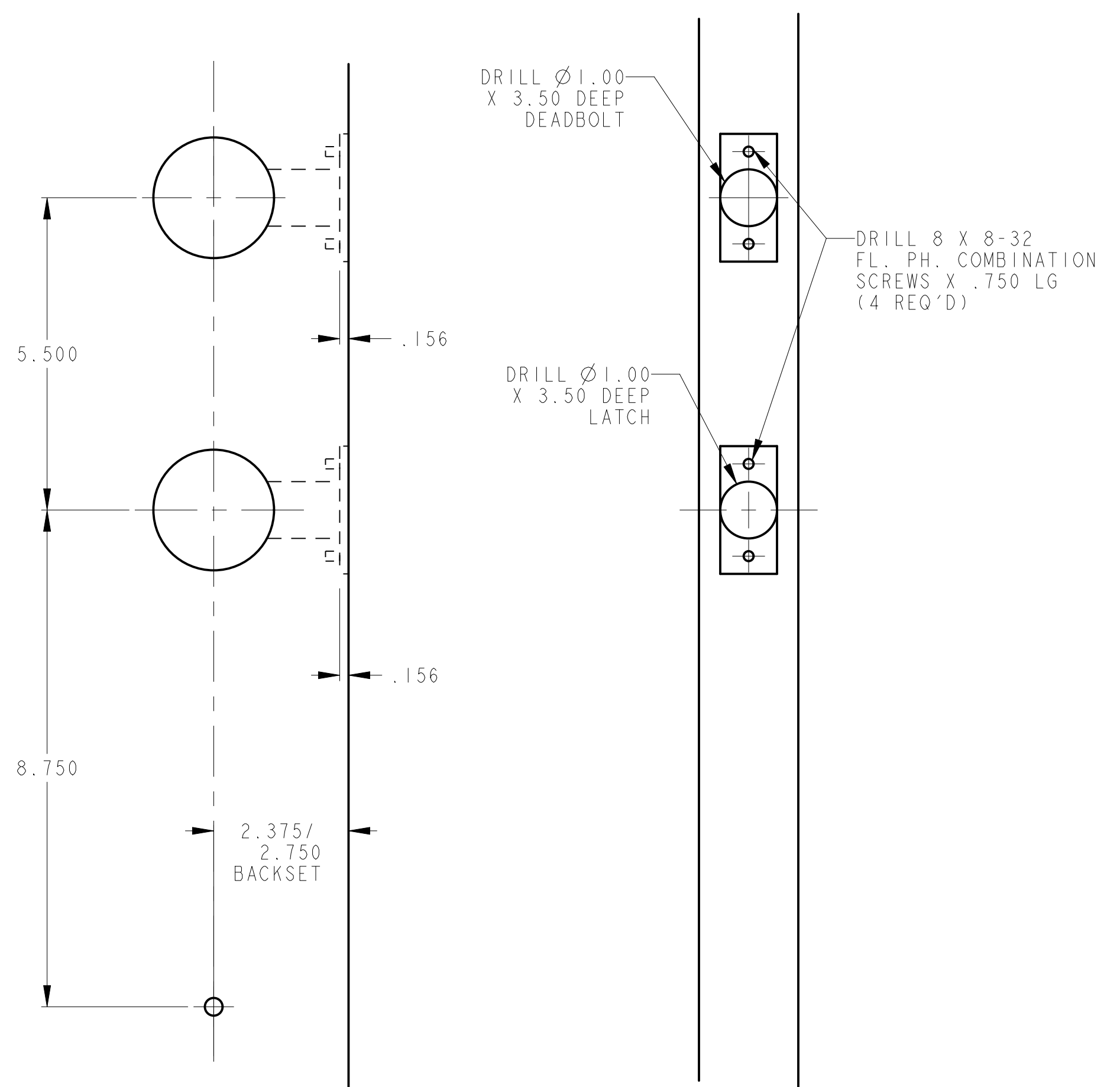

DEADBOLT STRIKE

LATCH STRIKE

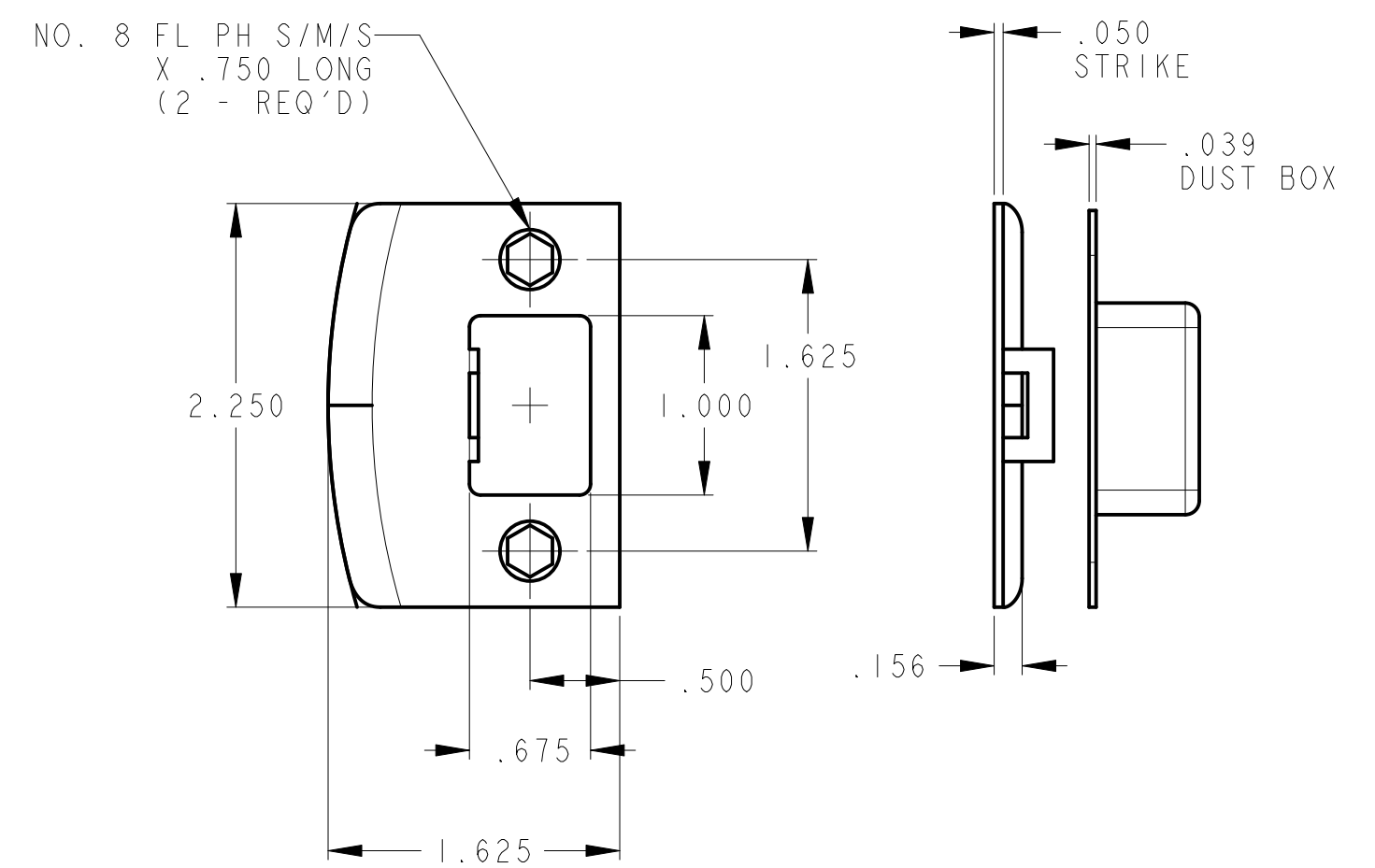
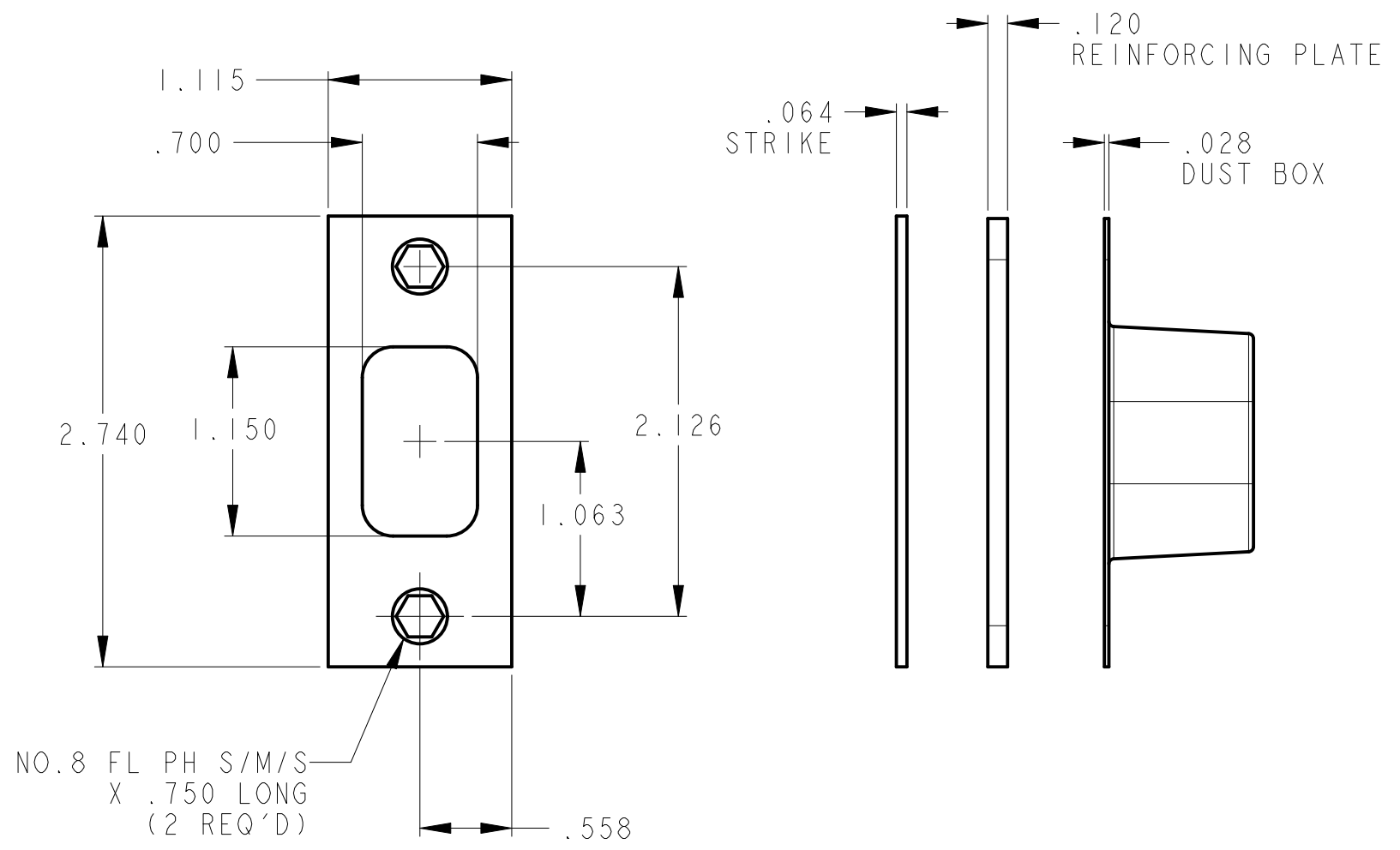

NOTE:
1. TURN KNOB IS NOT CONCENTRIC TO Ø 2.125 BORE HOLE.

BALDWIN Spectrum Brands Hardware & Home Improvement		THIS DOCUMENT IS THE PROPERTY OF SPECTRUM BRANDS. IT SHALL REMAIN THE PROPERTY OF SPECTRUM BRANDS. IT IS TO BE USED ONLY FOR THE PROJECT AND FOR THE CONTRACTOR'S USE. IT IS TO BE KEPT IN THE PROJECT OFFICE AT ALL TIMES. IT IS TO BE RETURNED TO SPECTRUM BRANDS UPON COMPLETION OF THE PROJECT. UNAUTHORIZED REPRODUCTION, COPIES, OR PUBLISHED PRODUCT SPECTRUM BRANDS. PRIOR WRITTEN CONSENT.	TITLE 85311 HOLLYWOOD HILLS FULL HS
SIZE D	DO NOT SCALE DRAWING	DWG NO P12388	RELEASE STATE Production
SCALE 1/2	SHEET 3 OF 7	REV 1	ITER 0

DOOR DETAIL

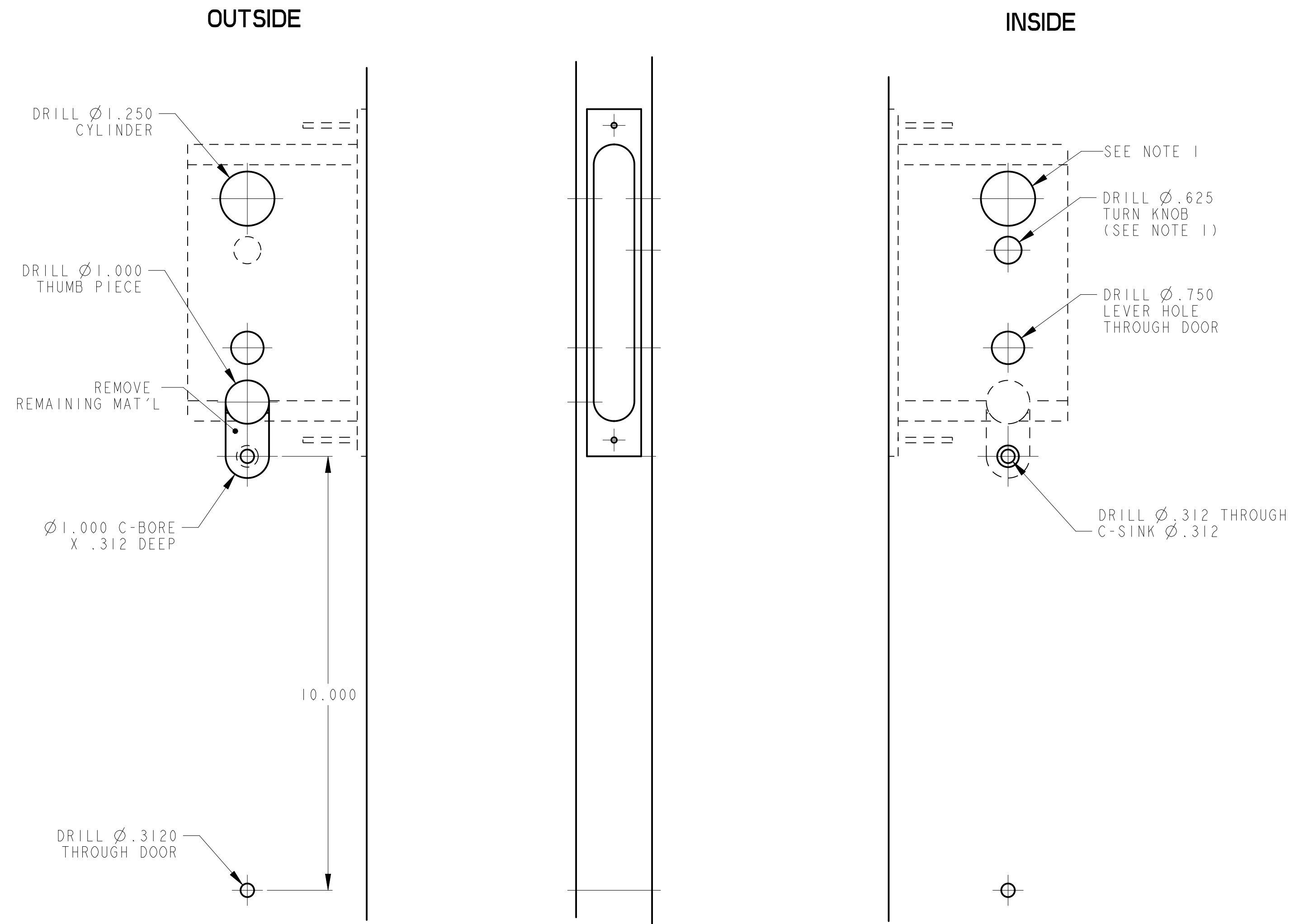

NOTE:
 1. WHEN PREPARING DOOR FOR DOUBLE CYLINDER FUNCTION, OMIT DRILLING OF $\varnothing .625$ TURN KNOB HOLE (INSIDE). INSTEAD DRILL $\varnothing 1.250$ CYLINDER HOLE USING SAME CENTER LINE AS OUTSIDE CYLINDER HOLE.
 2. FOR ADDITIONAL LOCK AND DOOR CUTOUT DIMENSIONS, SEE APPROPRIATE LOCK TEMPLATE.
 3. DRILL ALL HOLES HALF WAY THROUGH DOOR UNLESS OTHERWISE SPECIFIED.
 4. INSTALLATION PLATES ARE NOT REQUIRED FOR THIS TRIM.

TRIM DETAIL

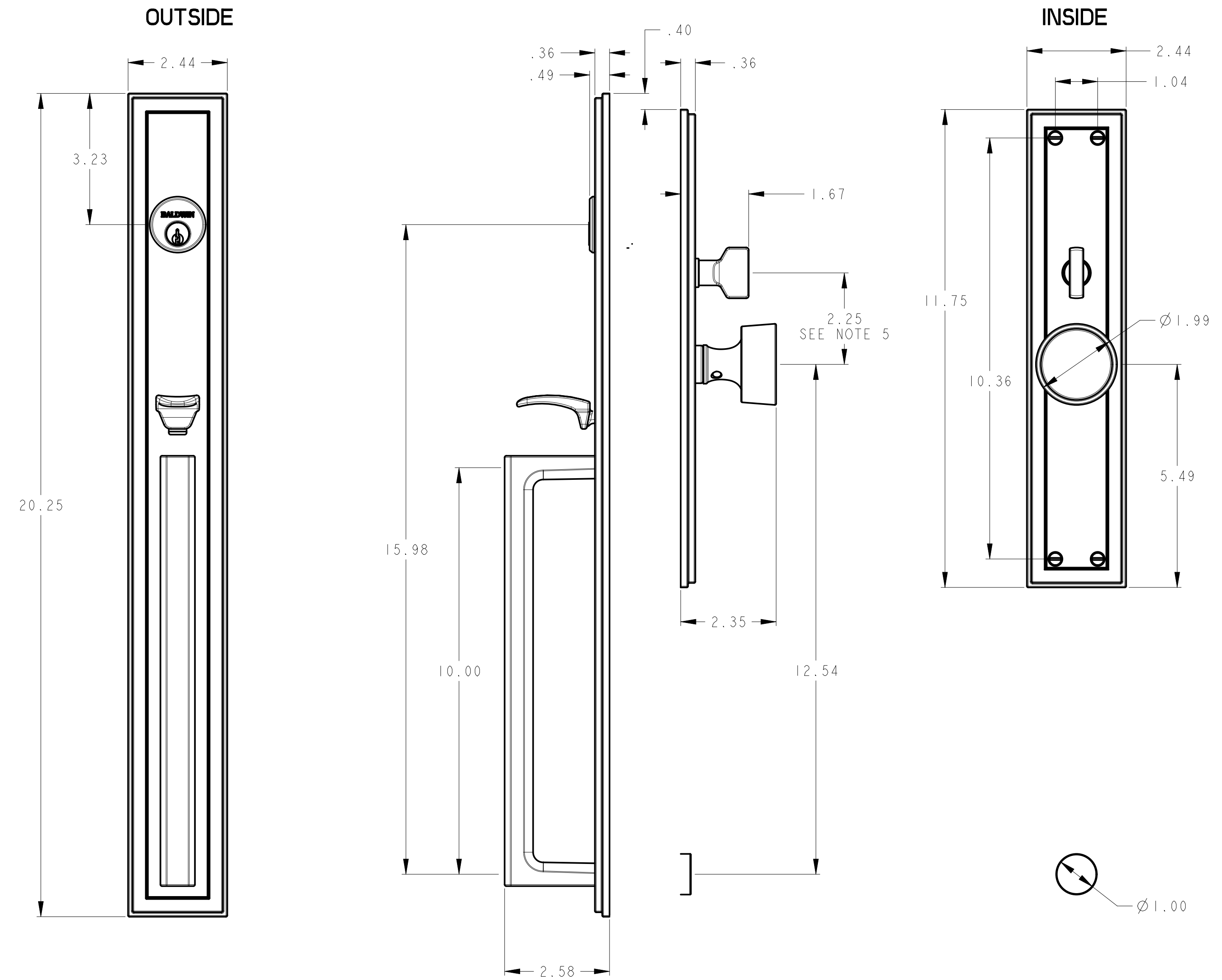

BALDWIN Spectrum Brands Hardware & Home Improvement		THIS DOCUMENT IS THE PROPERTY OF SPECTRUM BRANDS. IT AND ITS CONTENTS ARE UNCLASSIFIED AND FOR THE USE OF THE CUSTOMER. IT IS TO BE KEPT CONFIDENTIAL AND NOT TO BE REPRODUCED, COPIED, OR DISSEMINATED IN ANY MANNER WITHOUT THE WRITTEN CONSENT OF SPECTRUM BRANDS.	TITLE: 6946 HOLLYWOOD HILLS MRTS HS SIZE: D DO NOT SCALE DRAWING DWG NO: P12388 RELEASE STATE: Production SCALE: 1/4 SHEET: 4 OF 7
REV: 1	TITLE: 1	ITER: 0	REV: 1

REV	DESCRIPTION
1	SEE SHEET 1

DOOR DETAIL

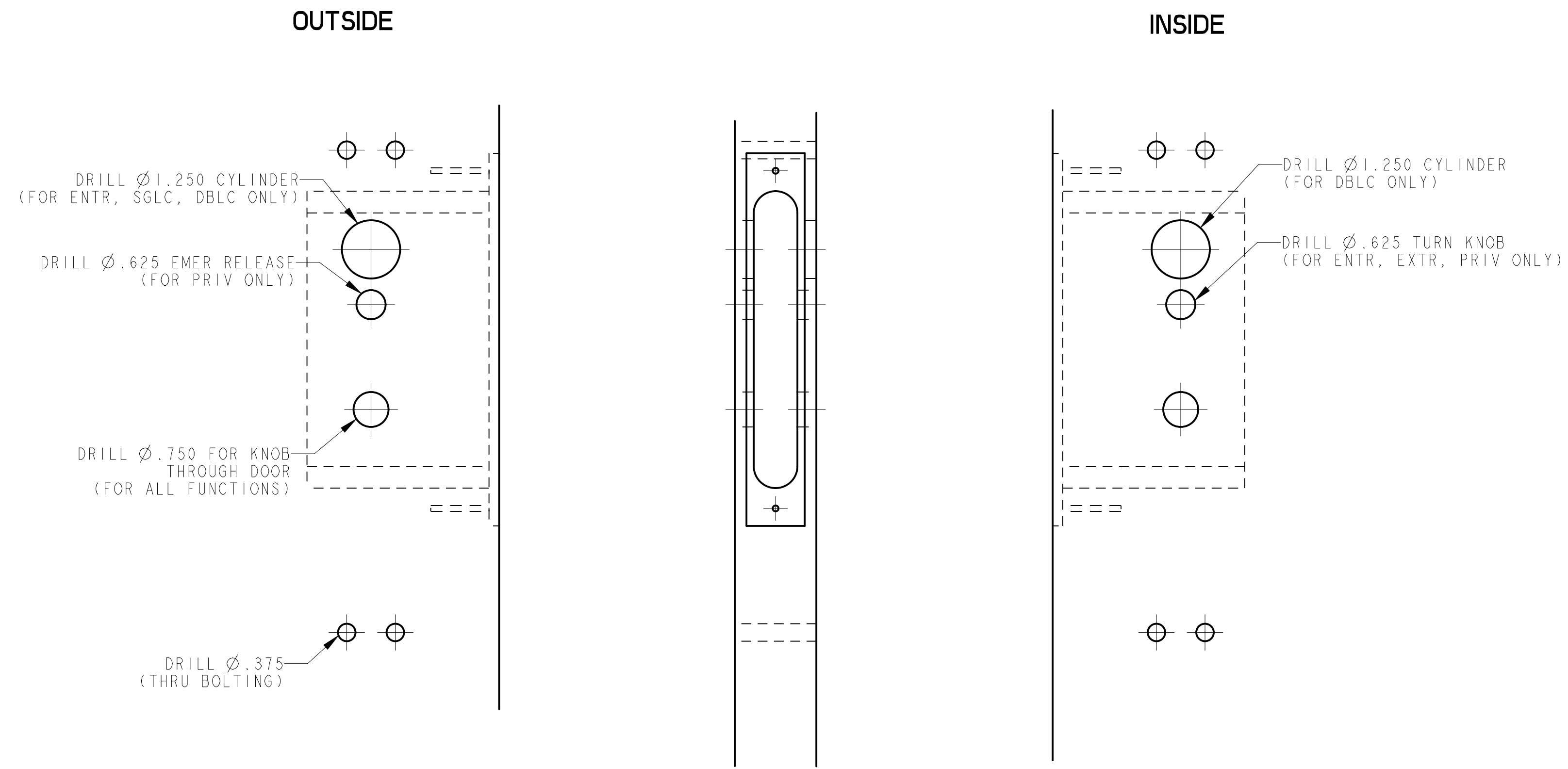

NOTE:
 1. FOR ADDITIONAL LOCK AND DOOR CUTOUT DIMENSIONS, SEE APPROPRIATE LOCK TEMPLATE.
 2. DRILL ALL HOLES HALFWAY THROUGH DOOR UNLESS OTHERWISE SPECIFIED.
 3. TO ENABLE EMERGENCY TRIM TO FUNCTION, THE TURN PIECE SPINDLE MUST BE CUT TO EXTEND NO FURTHER THAN HALF WAY THROUGH THE LOCK.
 4. INSTALLATION PLATES ARE NOT REQUIRED FOR THIS TRIM.

TRIM DETAIL

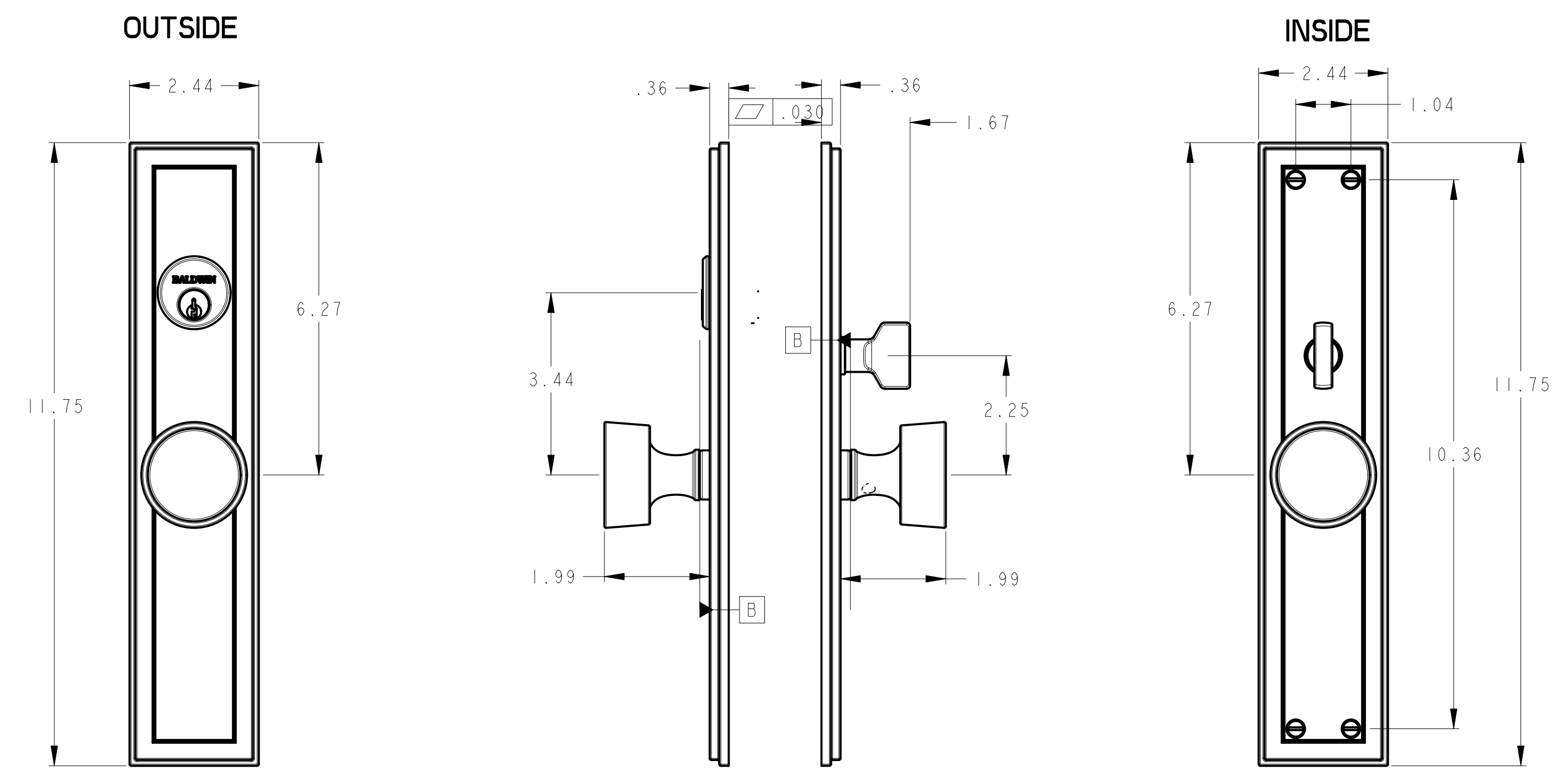

BALDWIN		THIS DOCUMENT IS THE PROPERTY OF SPECTRUM BRANDS. NO PART OF THIS DOCUMENT IS TO BE REPRODUCED, COPIED, OR TRANSMITTED IN ANY FORM OR BY ANY MEANS, ELECTRONIC OR MECHANICAL, INCLUDING PHOTOCOPYING, RECORDING, OR BY ANY INFORMATION STORAGE AND RETRIEVAL SYSTEM, WITHOUT THE EXPRESS WRITTEN PERMISSION OF SPECTRUM BRANDS. PRIOR WRITTEN CONSENT.	
Spectrum Brands Hardware & Home Improvement		6945 ENTR	
SIZE: D	DO NOT SCALE DRAWING	DWG NO: P12388	REV: 1
SCALE: 1/2		RELEASE STATE: Production	TITER: 0
SHEET: 5		OF: 7	

8

7

6

5

4

3

PDM REF D: 1.0 M: A.9

1

REV	DESCRIPTION
1	SEE SHEET 1

DO NOT SCALE DRAWING

OUTSIDE

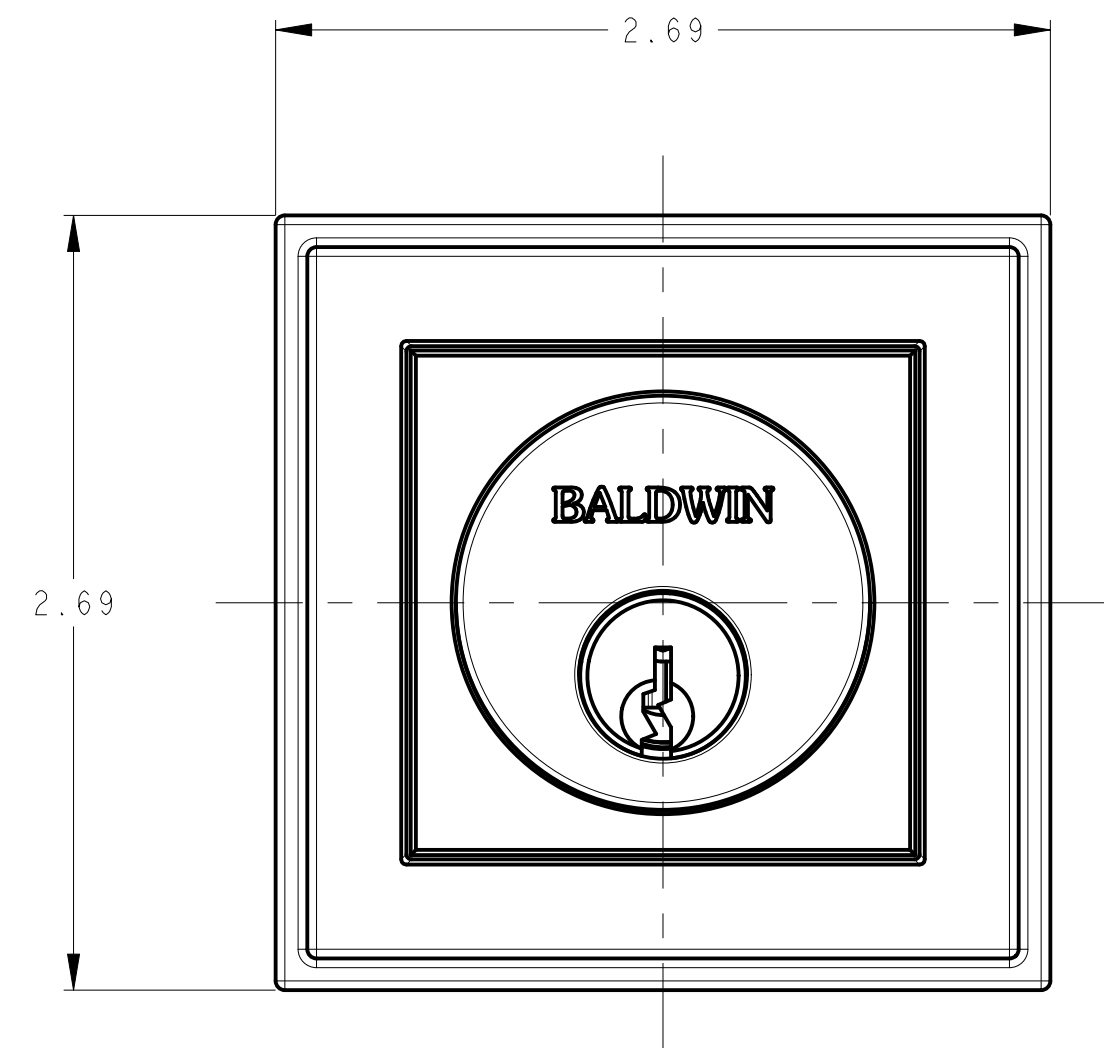

TRIM DETAIL

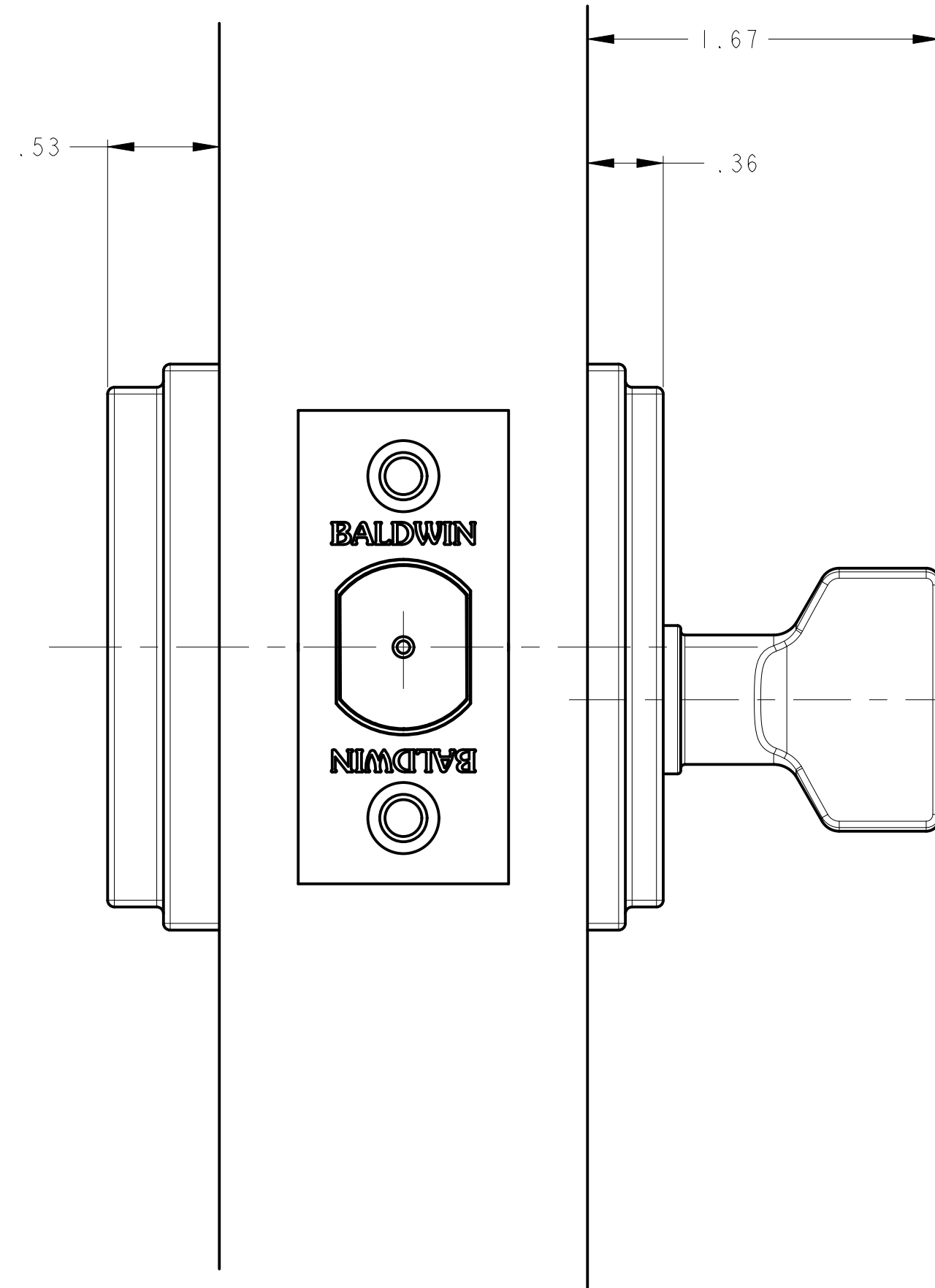

INSIDE

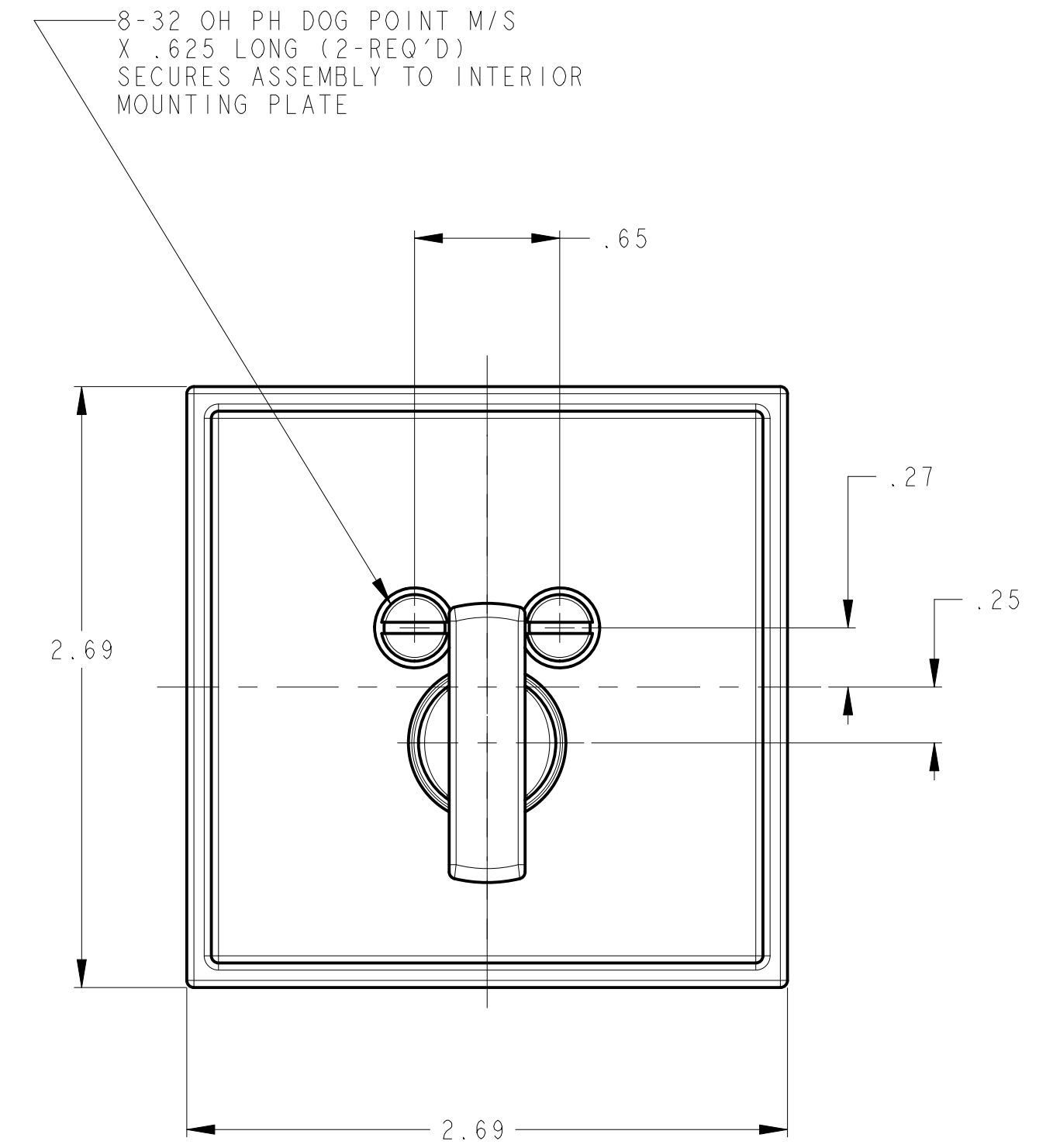

DOOR DETAIL

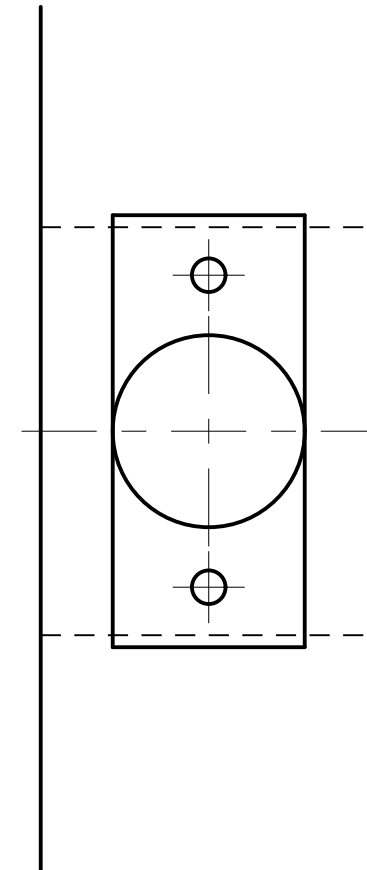
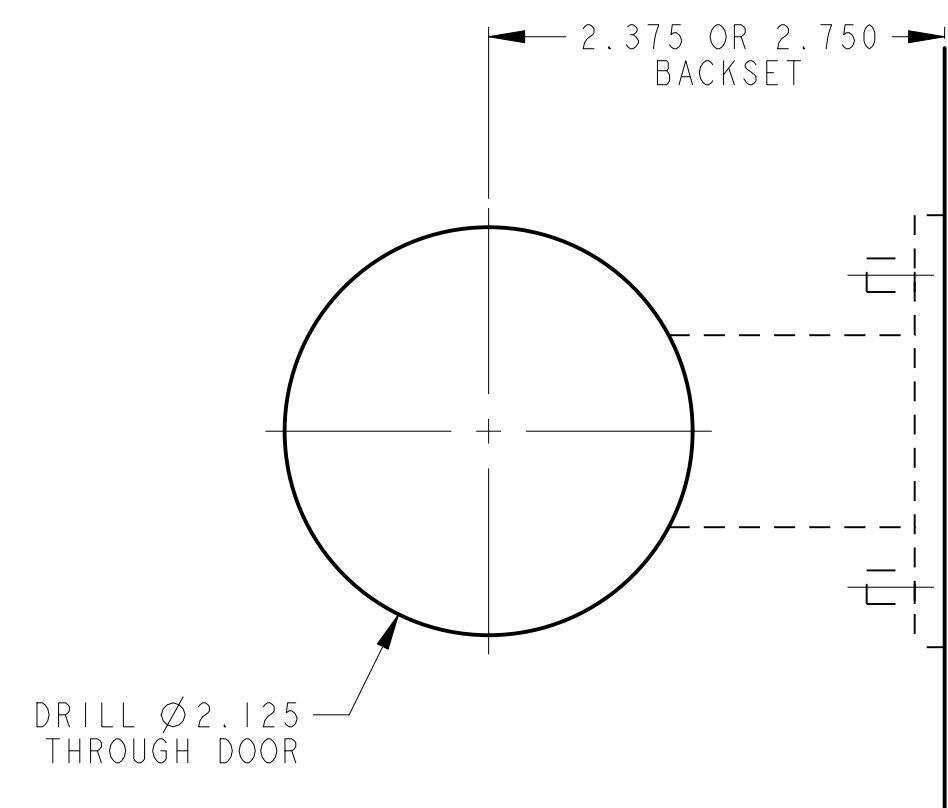

TITLE
8260 DEADBOLT SINGLE CYL

BALDWIN
Spectrum Brands | Hardware & Home Improvement

SIZE D	DO NOT SCALE DRAWING	DWG NO P12388
RELEASE STATE	Production	REV 1
SCALE 1/2		LITER 0
		SHEET 6 OF 7

TRIM DETAIL

OUTSIDE

INSIDE

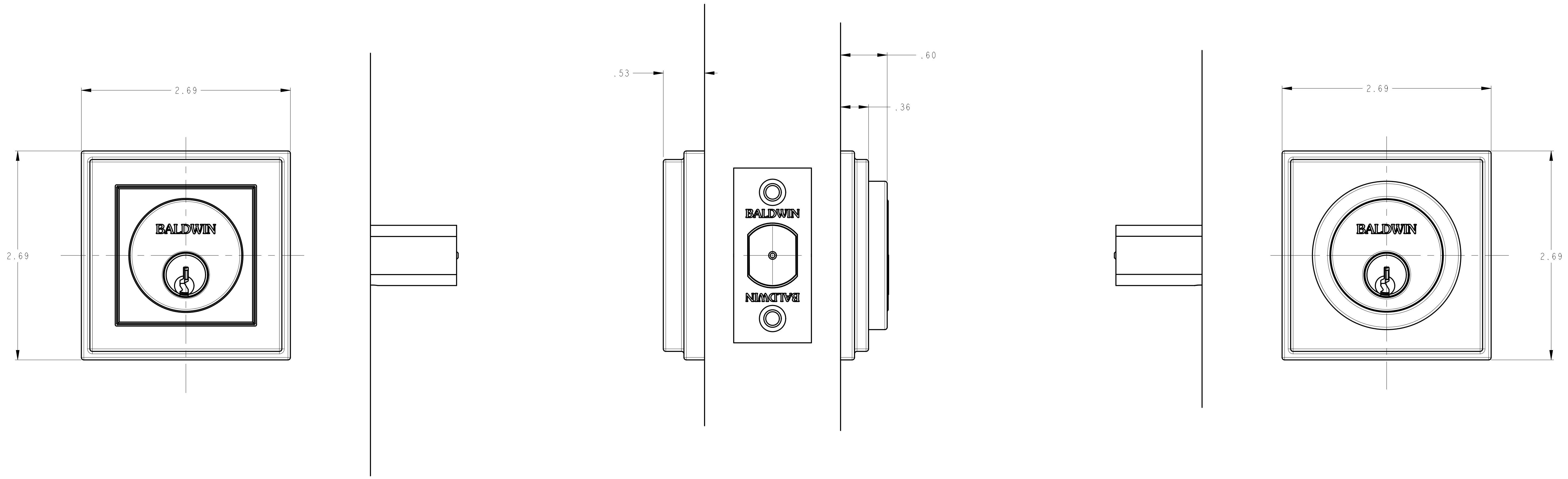

DOOR DETAIL

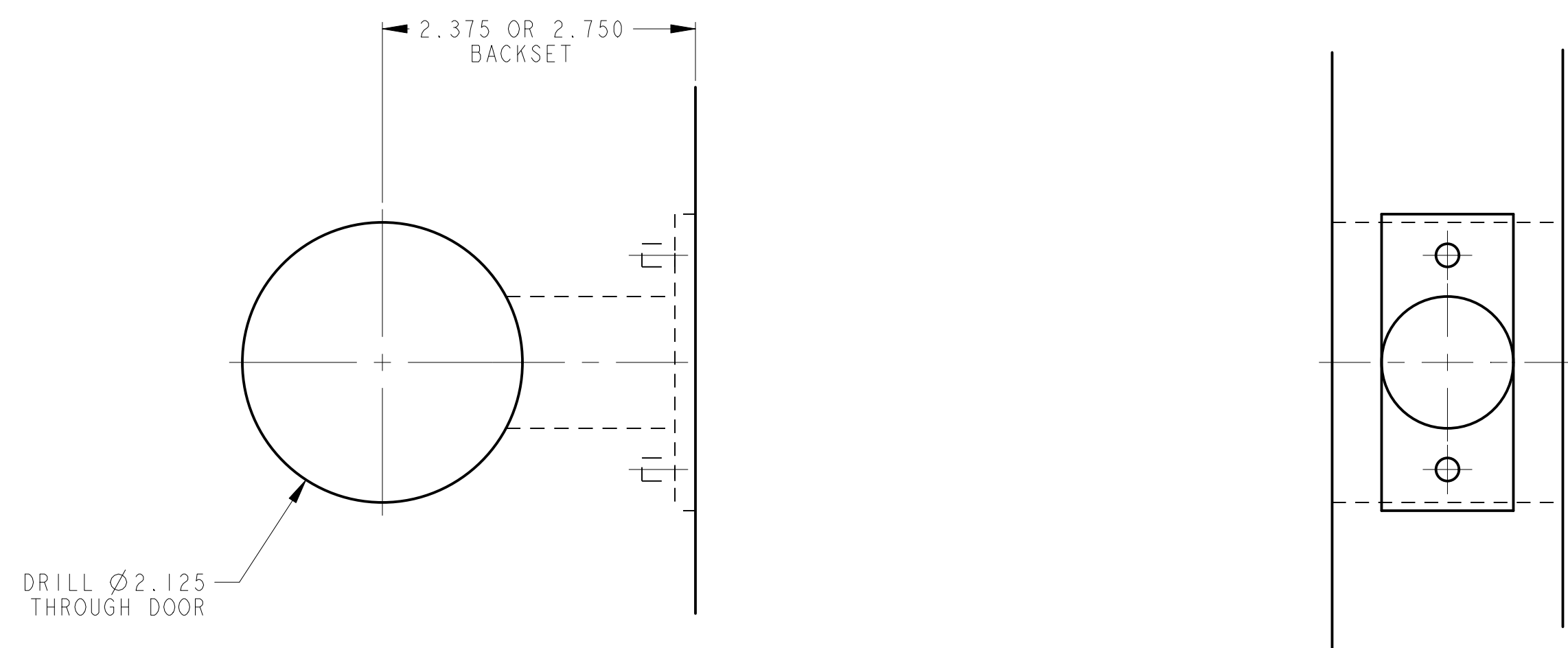

BALDWIN		THIS DOCUMENT IS THE PROPERTY OF SPECTRUM BRANDS. NO PART OF THIS DOCUMENT, THE CONTENTS OF THIS DOCUMENT, OR ANY INFORMATION CONTAINED HEREIN IS TO BE REPRODUCED, COPIED, OR TRANSMITTED IN ANY FORM OR BY ANY MEANS, ELECTRONIC OR MECHANICAL, INCLUDING PHOTOCOPYING, RECORDING, OR BY ANY INFORMATION STORAGE AND RETRIEVAL SYSTEM, WITHOUT THE EXPRESS WRITTEN PERMISSION OF SPECTRUM BRANDS. SPECTRUM BRANDS, THE SPECTRUM BRANDS LOGO, AND THE SPECTRUM BRANDS DESIGN ARE TRADEMARKS OF SPECTRUM BRANDS. ALL RIGHTS RESERVED.	
Spectrum Brands	Hardware & Home Improvement	8261 DEADBOLT DOUBLE CYL	P12388
SIZE D	DO NOT SCALE DRAWING	DWG NO	P12388
RELEASE STATE	Production	REV	1
SCALE 1/2		SHEET	7 OF 7