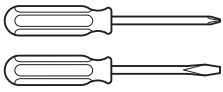

Installation Guide for PD005/PD006 Trim
Guía de instalación para el contramarco PD005/PD006
Guide d'installation pour la plaque de finition PD005/PD006

PK.1291 Rev 01 PD005/PD006 Trim

<p>Step 1 Use the mortise template to prep the door edge.</p> <p>Step 2 Use the trim template to prep the face of the door.</p> <p>Step 3 Install the mortise.</p> <p>Step 4 Install the trim.</p>	<p>Paso 1 Utilice la plantilla de la mortaja para preparar el borde de la puerta.</p> <p>Paso 2 Utilice la plantilla del contramarco para preparar la cara de la puerta.</p> <p>Paso 3 Instale la mortaja.</p> <p>Paso 4 Instale el contramarco.</p>	<p>Étape 1 Utiliser le gabarit de la mortaise pour préparer le bord de porte.</p> <p>Étape 2 Utiliser le gabarit le plus petit pour préparer la face de la porte.</p> <p>Étape 3 Installer la mortaise.</p> <p>Étape 4 Installer la plaque de finition.</p>	<p>Required Tools Herramientas necesarias Outils nécessaires</p> 
--	--	---	--

Passage Trim

Contramarco de paso
Plaque de finition de passage

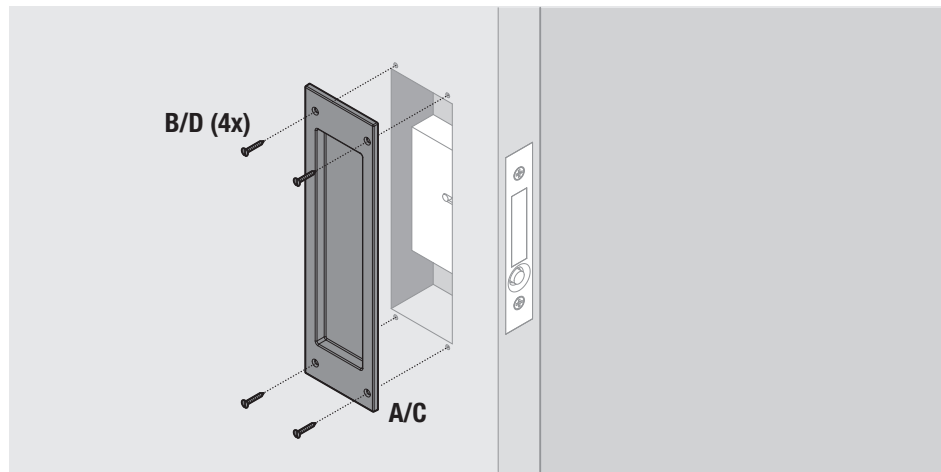
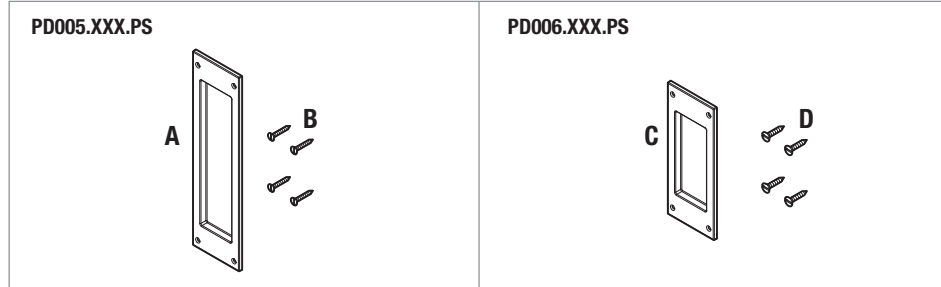

Trim with Turn Knob or Emergency Release Turnpiece

Contramarco con perilla de giro o perilla de liberación de emergencia
Plaque de finition avec bouton pouscier ou bouton du type serrure camarde

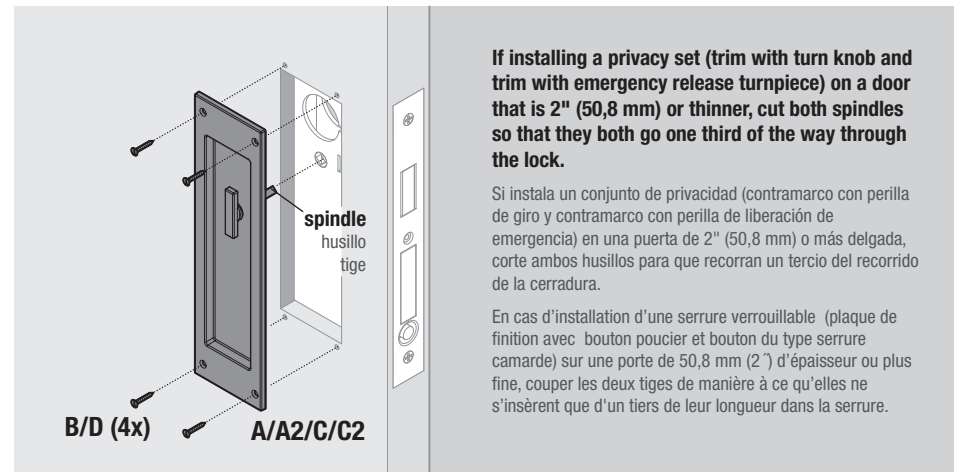
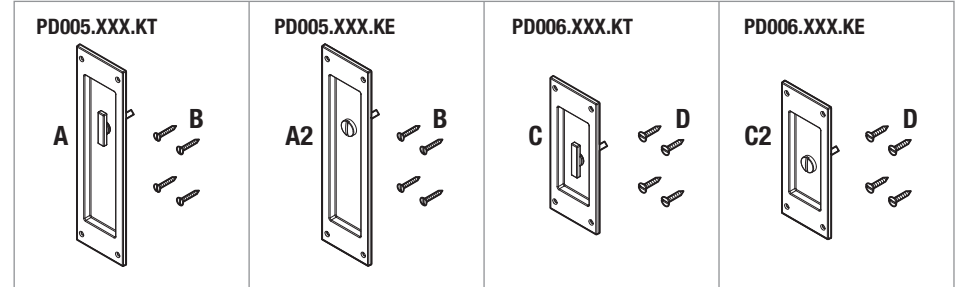

Trim with Cylinder

Contramarco con cilindro
Plaque de finition avec cylindre

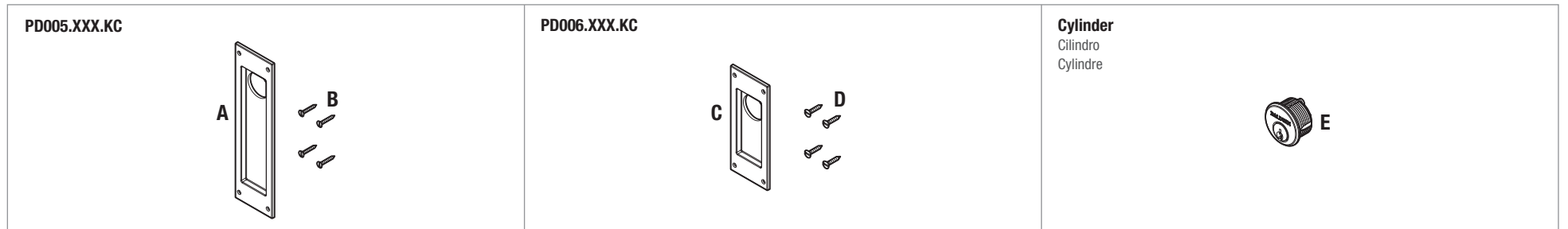

1 Install trim and cylinder
Instale el contramarco y el cilindro
Installer la plaque de finition et le cylindre

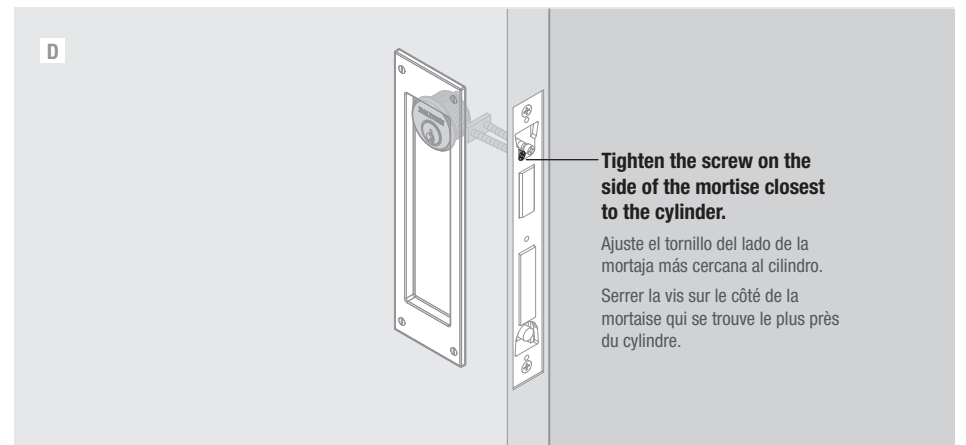
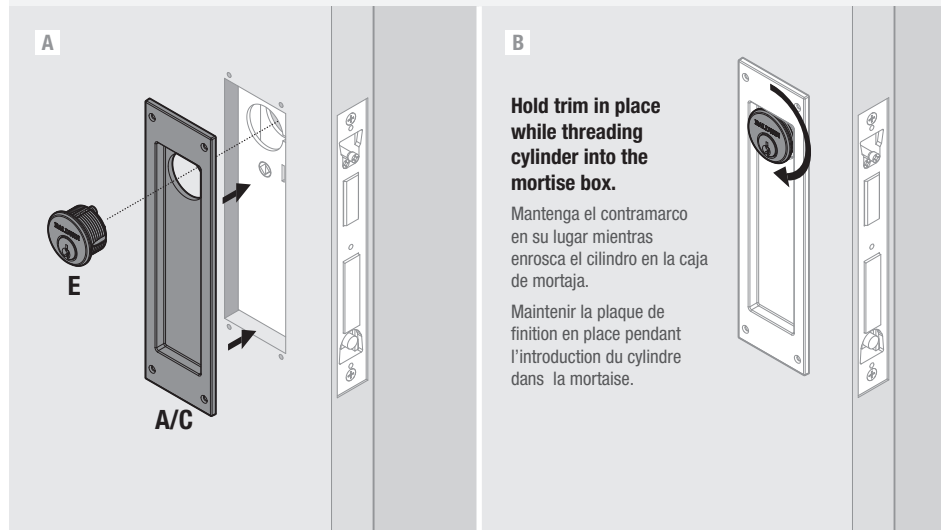

2 Install faceplate
Instale la placa frontal
Installer la plaquette

