

DO NOT PRINT THIS PAGE

Printing Notes:

Material: 20 Pound (US) or 80 GSM (International) bond paper, white
Ink: Black

Resolution: 150 DPI or above

Printing method: Offset Printing

Binding: Saddle Stitch

Folded size: 4 x 8.5 in (W x H)

*This drawing contains proprietary information and trade secrets of The Coleman Company, Inc.
 Unauthorized use or copying is prohibited.*

METRIC (INCH)								
CRITICAL DIMENSION								
CHECKING IS COMPULSORY								
		03	20-NOV-12	Revised Motor Mounting and Repairing Small Punctures sections.	Abby	20026736		
		02	8-SEP-10	Added Hui sport information in the IM.	David	20015156		
VOLUME	cm ³	01	28-JUL-09	NEW	Rainy	20009317		
MASS	grams	REV.	DATE	MODIFICATIONS	NAME	ECN NO.		
DENSITY	g/cm ³	MATERIAL: SEE NOTES				<i>The Coleman Company, Inc.</i> Wichita, Kansas USA 67219		
GENERAL TOLERANCES EXCEPT AS NOTED		FINISH SPEC.: SEE NOTES				COMPOSITE- NO	SHEET 1 OF 1	
0 TO	6mm	SCALE:		DATE:	DRAWN BY:	APPROVED BY:	REVISION:	
>6 TO	30mm	1:1		28-JUL-09	RR Xiang	SH		03
>30 TO	80mm							
>80 TO	180mm							
>180mm								
		NAME:				FRONT NO.:	4010006279	
ANGULAR	= ± 3°	INSTRUCTION MANUAL KAYAKS & CANOES						



INFLATABLE CANOES & KAYAKS

Including the following Model Series:
Sit On Top, Tahiti™, Rio™, Fastback™, Colorado™, Pointer™,
Hui Sport and Fiji™.

READ THE FOLLOWING INSTRUCTIONS AND WARNINGS TO AVOID DROWNING OR SERIOUS INJURY



CAUTION:

Safety Warning

Paddle sports can be very dangerous and physically demanding. The user of this product should understand that participating in paddle sports may involve serious injury or death. Observe the following safety standards whenever using this product.

- It is the owner's responsibility to carefully read the manual and instruct all users in safe operation of this product.
- Not a life saving device.
- Get paddle sport instruction specific to this type of craft.
- Obtain certified first aid training and carry first aid and safety/rescue equipment.
- Always wear an approved Personal Flotation Device (Life Preserver).
- Wear a helmet when appropriate.
- Dress appropriately for weather conditions; cold water and/or cold weather can result in hypothermia.
- Never paddle alone.
- Do not paddle in flood conditions.
- Be aware of river water levels, tidal changes, dangerous currents and weather changes.
- Do not use in high wind, strong currents, open water or dangerous tides.
- Scout unfamiliar waters; portage when appropriate.
- Do not exceed your paddling ability; be honest with yourself.
- Consult a physician prior to beginning your paddle sport training.
- Do not use this product under the influence of alcohol or drugs.
- Do not make any alterations to this product.
- Do not overload or over inflate.
- Never tow from another boat or vehicle.
- Know and follow local water safety rules and boating regulations.

IMPORTANT INFORMATION

The warnings below relate to various situations. Please observe them.

⚠ CAUTION!

Denotes an imminent hazard which will result in severe injury if you do not comply with the instructions.

⚠ WARNING!

Reminds you of safety measures which must be observed. Also denotes unsafe practices which could result in personal injury or damage to the product or property, if you do not comply with the instructions.

⚠ CAUTION!

It is the owner's responsibility to make sure all users carefully read and follow the instructions for safe operation of this product. Observe all local and national laws. Always wear a Personal Flotation Device approved by the proper authorities. Please carefully observe the Capacity Plate information which is printed on the product.

⚠ WARNING!

These products are not meant for towing because the extreme pressure of the water while towing can tear the eyelets and/or handles.

These products are made of the highest quality materials and comply with NMMA (National Marine Manufacturers Association) regulations.

⚠ CAUTION!

Altering the construction of these products could jeopardize the safety of the occupants and will void the limited warranty.

⚠ CAUTION!

Do not over inflate. Pressurize product to "Inflation Pressure" stated in the chart for your specific product.

⚠ WARNING!

Never use a compressor, CO₂ or compressed air to inflate the product. Do not let your product come into contact with sharp, pointed objects.

⚠ CAUTION!

Keep product away from gasoline, battery acid, solvents, etc., as they can damage the product.

INFLATION INSTRUCTIONS

To inflate using any Sevylor® QuickPump™ unit:

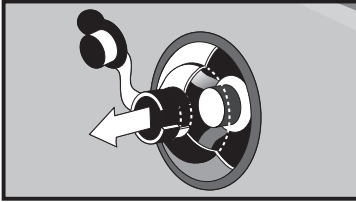

1. To begin inflation, open external cap and pull firmly on the lanyard to extend out. This will open internal yellow seal.

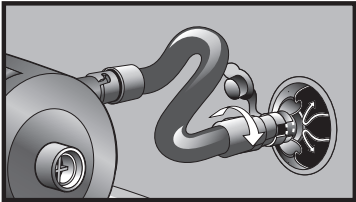

3. When fully inflated, seal valve by pushing in with pump nozzle. This will seal the internal yellow stopper and keep air from escaping while closing cap. Gently twist adapter nozzle to right while backing pump out of valve.

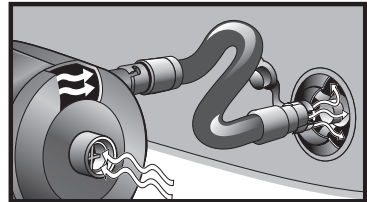

2. Attach adapter nozzle to inflation end of pump. Insert pump and turn on.
Note: The pump may look different from yours. It is for illustration purposes only.

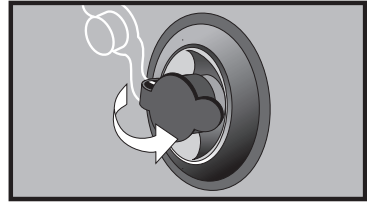

4. Fully remove pump and close external cap. Valve should appear depressed into itself.

To inflate using the Sevylor® Dual Action Hand Pump or other inflation device:

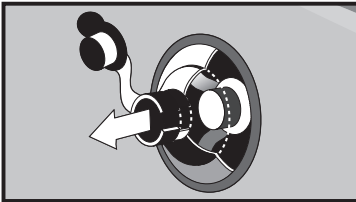

1. To begin inflation, open external cap and pull firmly on the lanyard to extend out. This will open internal yellow seal.

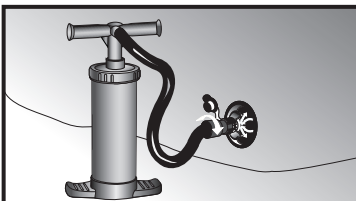

3. When fully inflated, seal valve by pushing in with pump nozzle. This will seal the internal yellow stopper and keep air from escaping while closing cap. Gently twist adapter sleeve to right while backing pump out of valve.

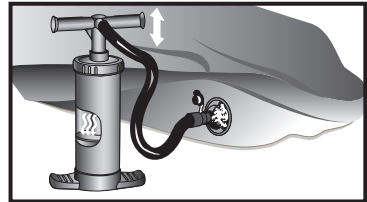

2. Attach adapter nozzle to inflation end of pump. Insert pump and turn on or start pumping.
Note: The pump may look different from yours. It is for illustration purposes only.

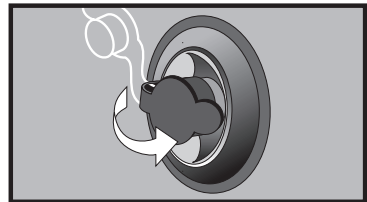

4. Fully remove adapter and close external stopper. Valve should appear depressed into itself.

IMPORTANT! Inflate the product chambers in the following order:

1. Inflate the floor chamber(s).
2. Inflate the outside main chamber(s).

The chambers on the product will also be numbered to indicate order of inflation. This order of inflation will ensure the proper volume and buoyancy of the safety chamber.

Note: To inflate the mini Double Lock™ valve, which is used on some of the Sevylor® product floors and seat bottoms, follow the same inflation instructions above or previous instructions, using the mini Double Lock™ valve adapter. The mini Double Lock™ valve adapter is included with all Sevylor® pumps. The adapter can be purchased from Sevylor Customer Service by calling 1-800-835-3278 (Part Number 5010000707).

⚠ CAUTION!

Water temperature and weather does affect the pressure in inflatable products. In cold weather your product will lose some pressure due to the fact the air will contract. If this occurs, you may want to add a little air to improve your products performance. However, in hot weather, the air will expand. You must let some air out to prevent your product from failing due to overpressure. You should avoid exposing your product to extreme temperatures (hot or cold).

DEFLATION INSTRUCTIONS

Deflation instructions using any Sevylor® QuickPump™ unit:

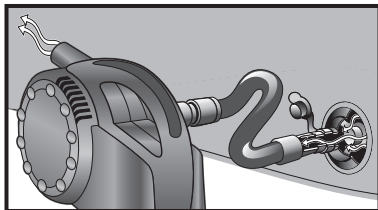

Remove adapter hose from inflation end and attach to opposite deflation end of pump. Repeat same steps as inflation. This will draw the air out quickly.

Deflation instructions using the Sevylor® Dual Action Hand Pump:

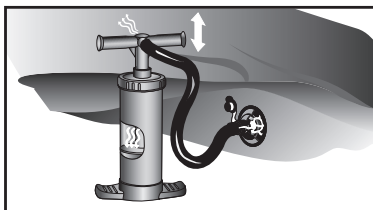

Remove adapter hose from inflation port and attach to deflation port. Repeat same steps as inflation. This will draw the air out quickly.

Your product is NMMA certified using the ABYC standard.



⚠ WARNING!

Do not exceed the certified maximum capacities under any circumstances!

NMMA (ABYC Standard)	Persons Capacity	Maximum Payload Capacity	Inflation Pressure	Inflation Pressure
Model #	Persons Only	Persons, Gear	Main Chamber(s)	Floor Chamber(s)
1 Person Sit On Top Kayak (Non Covered)	1 Pers. or 400 lbs.	400 lbs.	0.5 PSI	0.5 PSI
2 Person Sit On Top Kayak (Non Covered)	2 Pers. or 595 lbs.	595 lbs.	0.5 PSI	0.5 PSI

⚠ WARNING!

Do not exceed the certified maximum capacities under any circumstances!

NMMA (ABYC Standard)	Persons Capacity	Maximum Payload Capacity	Inflation Pressure	Inflation Pressure
Model #	Persons Only	Persons, Gear	Main Chamber(s)	Floor Chamber(s)
1 Person Sit On Top Kayak (Covered)	1 Pers. or 250 lbs.	250 lbs.	0.9 PSI	0.9 PSI
2 Person Sit On Top Kayak (Covered)	2 Pers. or 395 lbs.	395 lbs.	0.9 PSI	0.9 PSI

⚠ WARNING!

Do not exceed the certified maximum capacities under any circumstances!

NMMA (ABYC Standard)	Persons Capacity	Maximum Payload Capacity	Inflation Pressure	Inflation Pressure
Model #	Persons Only	Persons, Gear	Main Chamber(s)	Floor Chamber(s)
Tahiti™ Kayak	2 Pers. or 380 lbs.	400 lbs.	0.9 PSI	0.9 PSI
Tahiti™ Kayak - Fish/Hunt	2 Pers. or 380 lbs.	400 lbs.	0.9 PSI	0.9 PSI
Tahiti™ Kayak - Professional	2 Pers. or 380 lbs.	400 lbs.	0.9 PSI	0.9 PSI

⚠ WARNING!

Do not exceed the certified maximum capacities under any circumstances!

NMMA (ABYC Standard)	Persons Capacity	Maximum Payload Capacity	Inflation Pressure	Inflation Pressure
Model #	Persons Only	Persons, Gear	Main Chamber(s)	Floor Chamber(s)
Rio™ 1 Person Canoe	1 Pers. or 350 lbs.	350 lbs.	1.5 PSI	1.5 PSI
Rio™ 1 Person Canoe - Fish/Hunt	1 Pers. or 350 lbs.	350 lbs.	1.5 PSI	1.5 PSI

⚠ WARNING!**Do not exceed the certified maximum capacities under any circumstances!**

NMMA (ABYC Standard)	Persons Capacity	Maximum Payload Capacity	Inflation Pressure	Inflation Pressure
Model #	Persons Only	Persons, Gear	Main Chamber(s)	Floor Chamber(s)
Fastback™ 1 Person Kayak	1 Pers. or 400 lbs.	400 lbs.	0.5 PSI	0.5 PSI

⚠ WARNING!**Do not exceed the certified maximum capacities under any circumstances!**

NMMA (ABYC Standard)	Persons Capacity	Maximum Payload Capacity	Inflation Pressure	Inflation Pressure
Model #	Persons Only	Persons, Gear	Main Chamber(s)	Floor Chamber(s)
Colorado™ 2 Person Canoe	2 Pers. or 440 lbs.	500 lbs.	1.5 PSI	1.5 PSI
Colorado™ 2 Person Canoe - Fish/Hunt	2 Pers. or 440 lbs.	500 lbs.	1.5 PSI	1.5 PSI

⚠ WARNING!**Do not exceed the certified maximum capacities under any circumstances!**

NMMA (ABYC Standard)	Persons Capacity	Maximum Payload Capacity	Inflation Pressure	Inflation Pressure
Model #	Persons Only	Persons, Gear	Main Chamber(s)	Floor Chamber(s)
Pointer™ 1 Person Kayak	1 Pers. or 300 lbs.	300 lbs.	1.5 PSI	0.9 PSI
Pointer™ 2 Person Kayak	2 Pers. or 600 lbs.	600 lbs.	1.5 PSI	0.9 PSI

⚠ WARNING!

Do not exceed the certified maximum capacities under any circumstances!

NMMA (ABYC Standard)	Persons Capacity	Maximum Payload Capacity	Inflation Pressure	Inflation Pressure
Model #	Persons Only	Persons, Gear	Main Chamber(s)	Floor Chamber(s)
Fiji™ Travel Pack Kayak	2 Pers. or 380 lbs.	400 lbs.	0.9 PSI	0.9 PSI

⚠ WARNING!

Do not exceed the certified maximum capacities under any circumstances!

NMMA (ABYC Standard)	Persons Capacity	Maximum Payload Capacity	Inflation Pressure	Inflation Pressure
Model #	Persons Only	Persons, Gear	Main Chamber(s)	Floor Chamber(s)
Hui Sport Kayak	1 Pers. or 400 lbs.	400 lbs.	0.5 PSI	0.5 PSI

SEVYTEST™ GAUGE

Some of the Sevydor® products are equipped with a Sevytest™ gauge. The Sevytest™ device is a pressure gauge, not an inflation gauge. The Sevytest™ gauge is found on the side wall, inside the main chamber(s). The purpose is to show you when to let some air out after the pressure has increased due to temperature change.

The principle of the Sevytest™ gauge is based on the lengthening of the PVC under the influence of pressure. Once the boat is properly inflated, note the position of the Sevytest™ indicator. Then periodically check the Sevytest™ gauge and let out enough air to keep the test strip in the same general area. If the Sevytest™ indicator is in the “+” zone, add pressure to the product. If the Sevytest™ indicator is in the “-” zone, release pressure from the product.

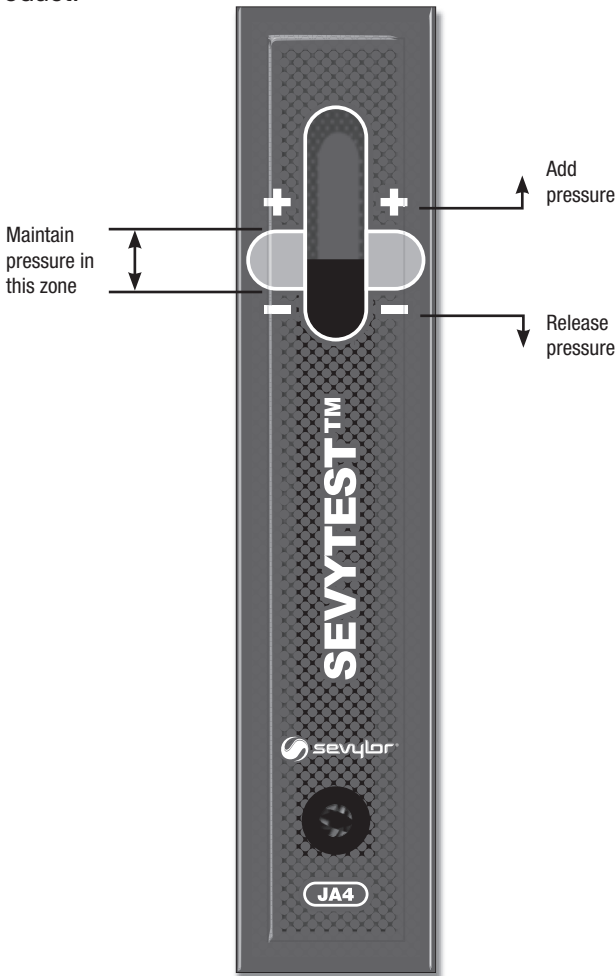

OPERATING INSTRUCTIONS:

- Follow all local boating regulations and navigation rules. Familiarize yourself with boating conditions where you plan to use the boat. Use common sense and caution when operating in unfamiliar places.
- Observe the maximum weight the product can carry and do not overload past this limit. Over-loading jeopardizes the safety of the occupants.
- Be sure all accessories and/or equipment (e.g. oars, life jackets) are in proper working condition before using the boat. Each person occupying the boat is to wear an approved Personal Flotation Device (life preserver).
- Sharp objects are not to be carried in the product without adequate protection or storage.
- When navigating the product in any water depth, watch for submerged or sharp objects that may damage or pierce the boat's air chambers.
- Enter the product from the port (left) or starboard (right) sides - not from the fore (front) or aft (back) sides.
- Never tow with a boat or any other vehicle.

MOTOR MOUNTING

⚠ CAUTION!

Do not mount a motor on any of these canoes or kayaks.

CARE & STORAGE:

- These products are made of the highest quality materials and comply with NMMA (National Marine Manufacturers Association) regulations. Altering the construction of these products will void the limited warranty and could jeopardize the safety of the occupants.
- If your product has been used in salt water, rinse it off with fresh water as soon as possible.
- Remove tar spots or other soiled areas by using a mild soap and rinsing with fresh water.
- Be sure your product is completely dry before storing.
- The products may be stored inflated, but do not place any heavy or sharp objects on it. Storage is best in a dry room.

REPAIRING SMALL PUNCTURES

Inadvertent punctures can be repaired using 3 different methods described below.

Included “Sticky Back Repair Patch” (included with select models only)

1. Thoroughly clean and dry the damaged area. Completely deflate the product.
2. Cut a portion of the patch to cover the puncture and allow an additional ¼” on all sides. Always cut a round patch, never leave square corners.
3. Be sure the repair area is completely dry.
4. Peel the backing from the patch.
5. Adhere the patch to the puncture.
6. Using your thumb or finger, apply even pressure across the entire surface of the patch.

Included Vinyl Repair Patch (included with select models only)

If your model does not include the Sticky Repair Patch noted above, then it will come with a Vinyl Repair Patch. This vinyl repair patch does not include vinyl glue, but it can be purchased from any home or hardware store (PVC cement).

1. Thoroughly clean and dry the damaged area. Completely deflate the product.
2. Cut a portion of the patch to cover the puncture and allow an additional ¼” on all sides. Always cut a round patch, never leave square corners.
3. Be sure the repair area is completely dry.
4. Apply generous coat glue to the vinyl repair patch and to the product.
5. Allow the glue to dry for 2 to 3 minutes, or until the glue becomes tacky.
6. Apply the patch to the product, using your thumb or finger; apply even pressure across the entire surface of the patch. Make sure the edges of the patch are pressed down along the entire diameter.
7. Allow the product to dry for at least 10 hours before inflating and using.

Sevylor Air Seal (Model 2000003730 – not included)

The Sevylor AirSeal is another repair option for repairing small punctures, in inflatable products such as pool floats, small boats, air mattresses and rainwear. The Sevylor AirSeal can also be used as the vinyl glue, for the vinyl patch noted in the above section. Refer to the repair instructions included with the Sevylor AirSeal. The Sevylor AirSeal contains enough material for several small repairs, and is intended for use with 100% PVC products only.

Do not use with any other material.

Sevylor Repair Patch (Model 2000003731 – not included)

The Sevylor Repair Patch is another repair option for repairing small punctures, in inflatable products. It can be used on inflatable boats, canoes, kayaks, floats, vinyl mattresses, tents & rainwear. The Sevylor Repair Patch will repair punctures and small tears in inflatable products and the product can be used immediately after the repair is completed. No drying time is required.

You may purchase the Sevylor Repair Patch (Model 2000003731) and the Sevylor AirSeal (Model 2000003730) by calling Coleman Customer Service at 1-800-835-3278 or by going to www.sevylor.com.

Tahiti™

Optional directional skeg for below 3 models

2 PERSON FISH/HUNT

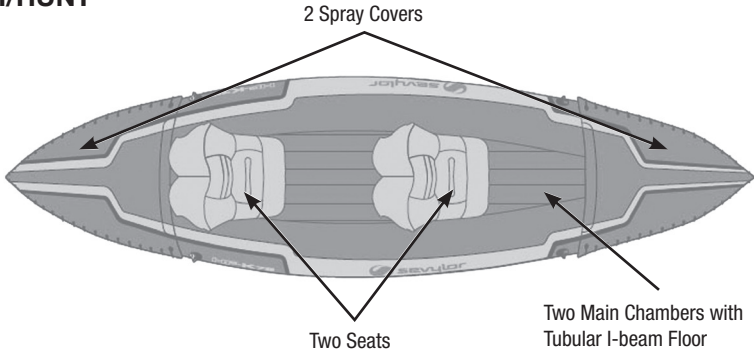

2 PERSON CLASSIC

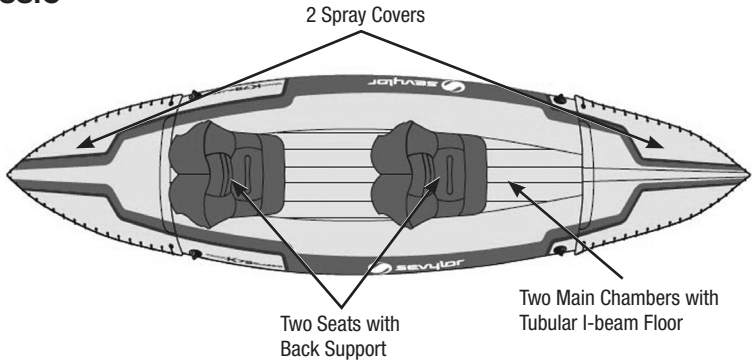

2 PERSON PRO SELF BAILER

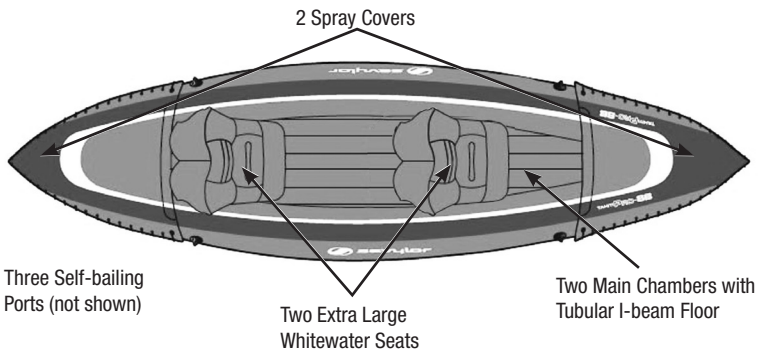

Pointer™

Water bottle holder on below 2 models (not shown)

1 PERSON

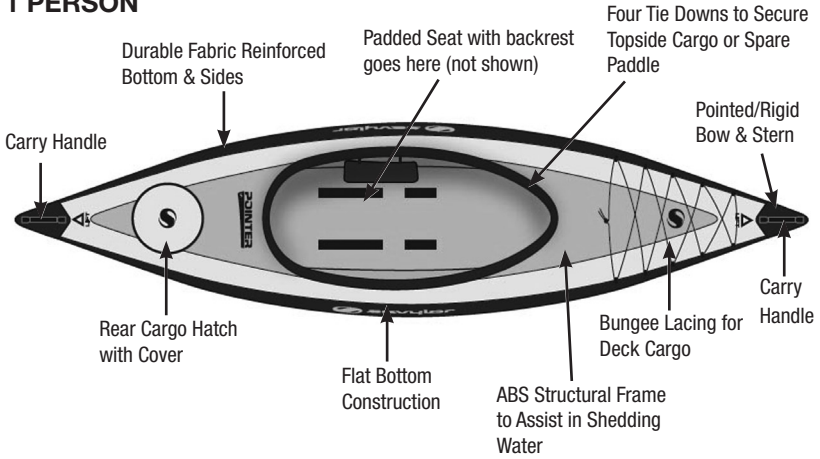

2 PERSON

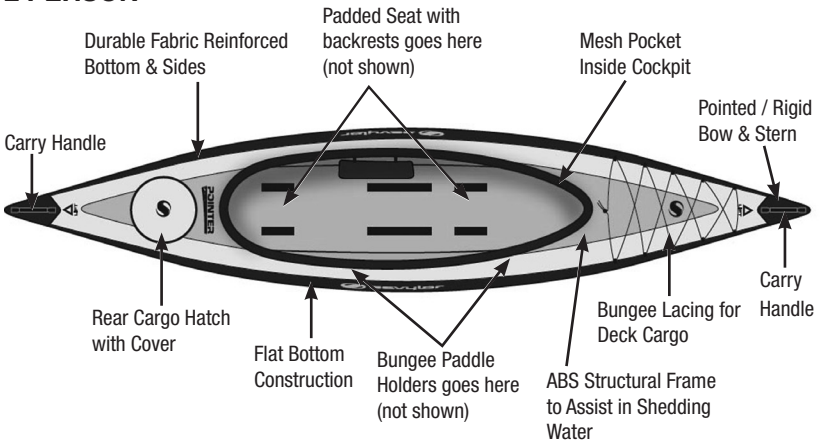

Fiji™

2 PERSON

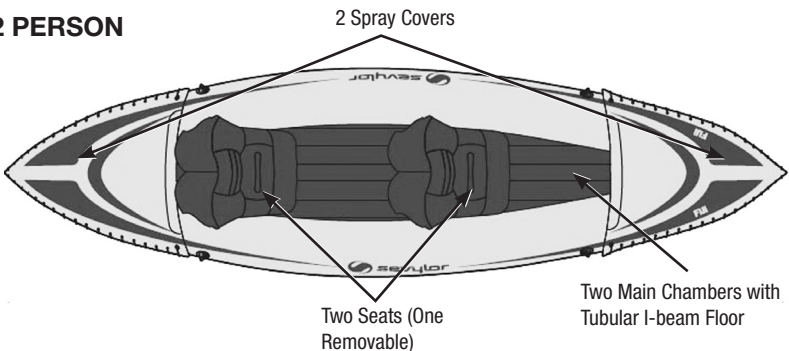

Colorado™

2 PERSON

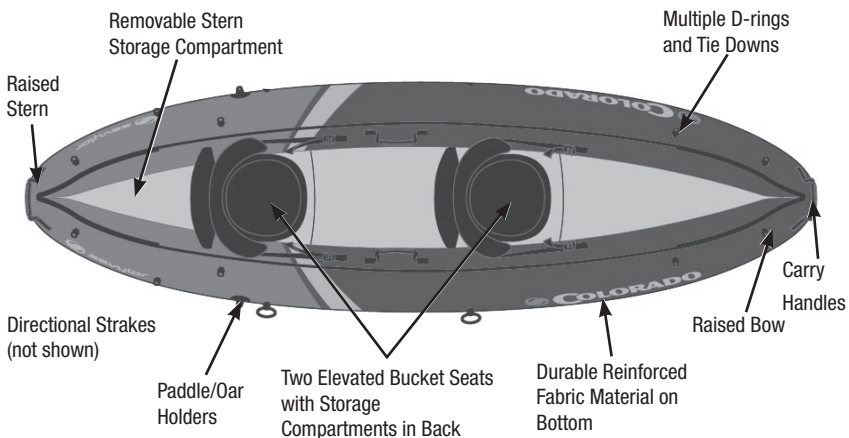

2 PERSON FISH/HUNT

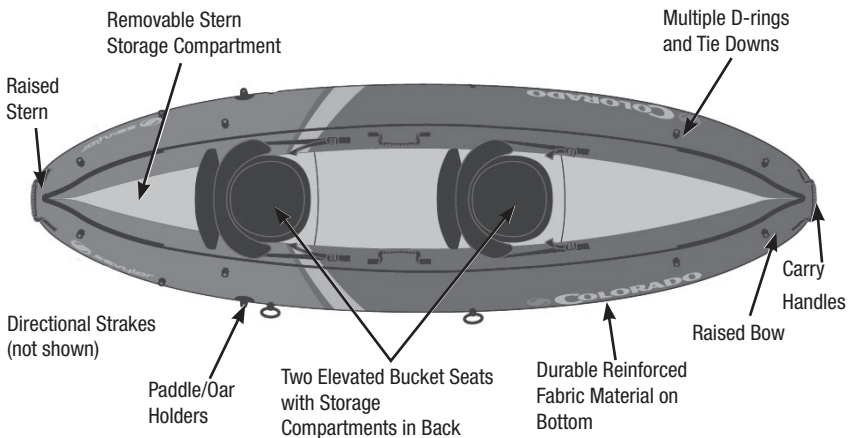

Rio™

1 PERSON

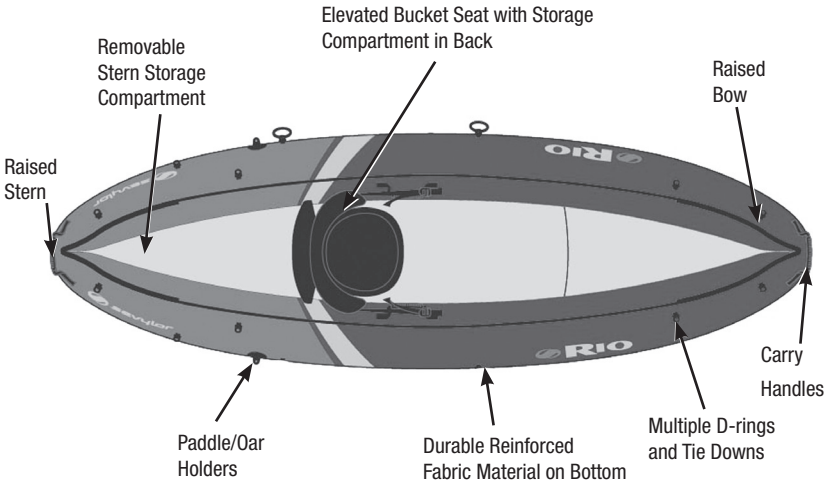

Directional Strakes
(not shown)

1 PERSON FISH /HUNT

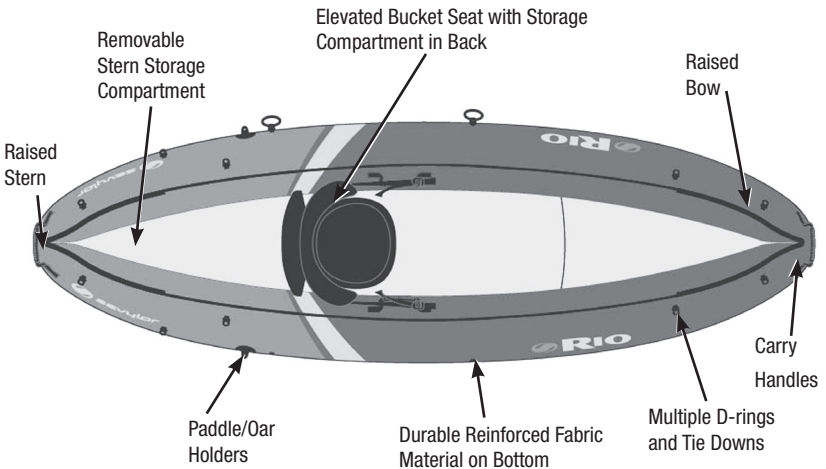

Directional Strakes
(not shown)

Sit On Top - Non Covered

2 PERSON

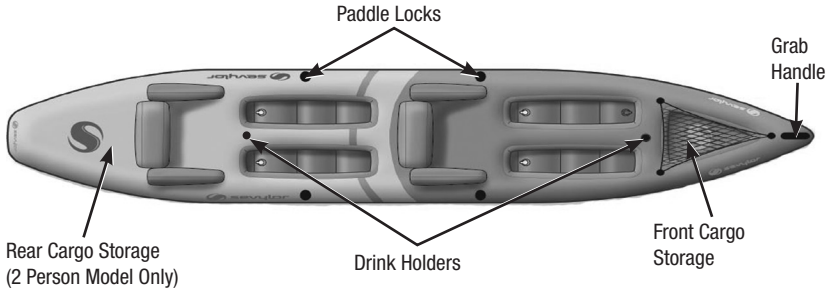

1 PERSON

Not shown. Has the same features as the 2 person except where noted and only has 1 seat.

Sit On Top - Covered

2 PERSON

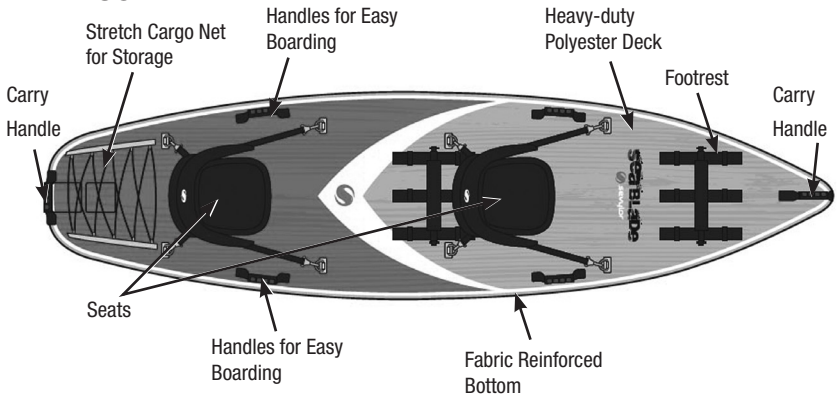

1 PERSON

Not shown. Has the same features as the 2 person and only has 1 seat.

Fastback™

1 PERSON

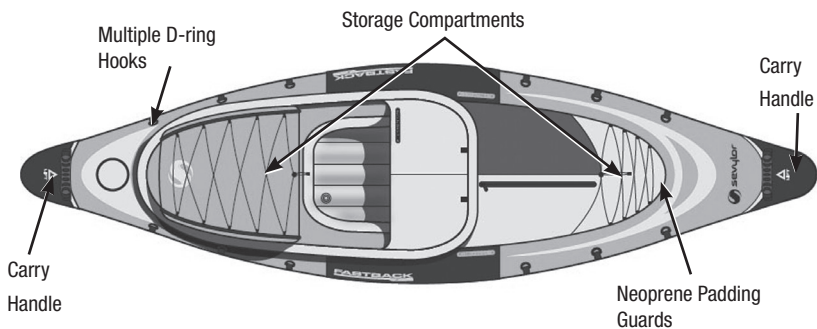

Hui Sport Kayak

1 PERSON

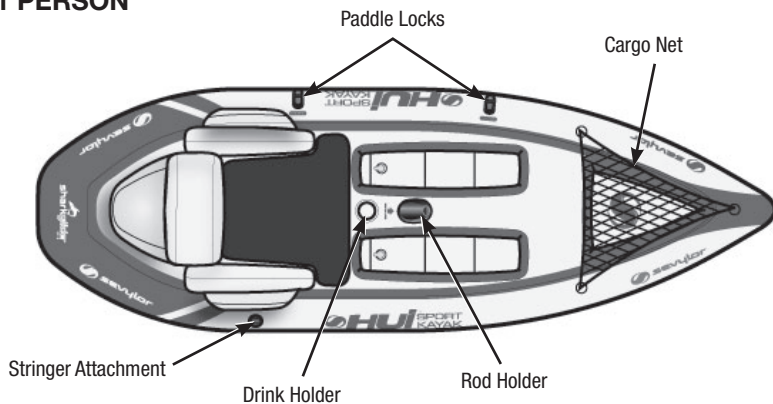

PADDLE ASSEMBLY: SELECT MODELS ONLY.

Join the three shafts together by screwing them together with the two couplers. Attach the blade to the shafts by screwing onto the end of the shaft.

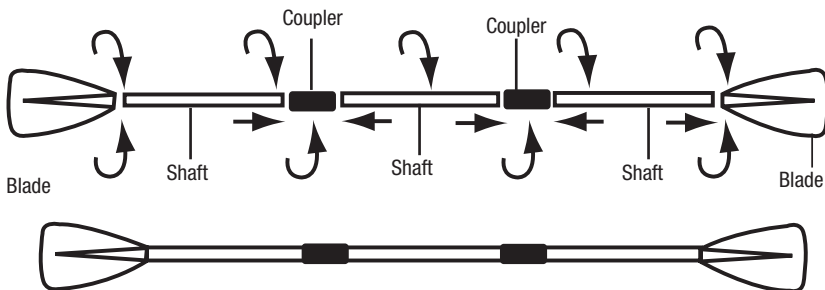

GUIDELINES FOR USAGE:

These kayaks may be wider than a typical kayak, which means they may feel more stable. However, as with any narrow, flat bottom kayak, users must be aware of the possibility of the kayak tipping and compensate for it. Paddle with short, even and easy strokes. Paddle close to the kayak with the paddle almost vertical. Pull with one hand and push with the other. If the nose of the kayak is moving right to left you are probably paddling too hard. Ease off on the force of your stroke to reduce the swaying of the front end. Paddling backward or breaking can sometimes offer quick maneuverability.

PRODUCT WARRANTY:

See the 90 days and 1 year limited warranty pages for details.

- Products without a fabric covered hull have a limited 90 day warranty. Models as follows: Sit On Top Kayak Series (Non-Covered), Tahiti Kayak Series, Hui Sport Kayak & Fiji Kayak.
- Products with a fabric covered hull have a limited 1 year warranty. Models as follows: Sit On Top Kayak Series (Covered) Rio Canoe Series, Colorado Canoe Series, Pointer Kayak Series & Fastback Kayak.

90 Days Limited Warranty

The Coleman Company, Inc. ("Coleman") warrants that for a period of 90 days from the date of original retail purchase, this product will be free from defects in material and workmanship. Coleman, at its option, will repair or replace this product or any component of the product found to be defective during the warranty period. Replacement will be made with a new or remanufactured product or component. If the product is no longer available, replacement may be made with a similar product of equal or greater value. This is your exclusive warranty.

This warranty is valid for the original retail purchaser from the date of initial retail purchase and is not transferable. Keep the original sales receipt. Proof of purchase is required to obtain warranty performance. Coleman dealers, service centers, or retail stores selling Sevylor® products do not have the right to alter, modify or in any way change the terms and conditions of this warranty.

What This Warranty Does Not Cover

This warranty does not cover normal wear of parts, parts that are not genuine Sevylor® parts, or damage resulting from any of the following: negligent use or misuse of the product; commercial use of the product; use contrary to the operating instructions; disassembly, repair or alteration by anyone other than Coleman or an authorized service center. Further, the warranty does not cover Acts of God, such as fire, flood, hurricanes and tornadoes. Warranty void if damage to product results from the use of a part other than a genuine Sevylor® part.

COLEMAN SHALL NOT BE LIABLE FOR DEFECTS THAT ARE CAUSED BY THE USE OF UNAUTHORIZED PARTS OR SERVICE. COLEMAN SHALL NOT BE LIABLE FOR ANY INCIDENTAL OR CONSEQUENTIAL DAMAGES CAUSED BY THE BREACH OF ANY EXPRESS OR IMPLIED WARRANTY OR CONDITIONS. EXCEPT TO THE EXTENT PROHIBITED BY APPLICABLE LAW, ANY IMPLIED WARRANTY OF MERCHANTABILITY OR FITNESS FOR A PARTICULAR PURPOSE IS LIMITED IN DURATION TO THE DURATION OF THE ABOVE WARRANTY OR CONDITIONS. SOME STATES, PROVINCES, OR JURISDICTIONS DO NOT ALLOW THE EXCLUSION OR LIMITATION OF INCIDENTAL OR CONSEQUENTIAL DAMAGES OR LIMITATIONS ON HOW LONG AN IMPLIED WARRANTY LASTS, SO THE ABOVE LIMITATIONS OR EXCLUSION MAY NOT APPLY TO YOU. THIS WARRANTY GIVES YOU SPECIFIC LEGAL RIGHTS, AND YOU MAY ALSO HAVE OTHER RIGHTS THAT VARY FROM STATE TO STATE OR PROVINCE TO PROVINCE.

How to Obtain Warranty Service

Take the product to an authorized Coleman service center. You can find the nearest authorized Coleman service center by visiting www.coleman.com or calling 1-800-835-3278 or TDD 1-316-832-8707 in the United States or 1-800-387-6161 in Canada. If a service center is not conveniently located, attach to the product a tag that includes your name, address, daytime telephone number and description of the problem. Include a copy of the original sales receipt.

Carefully package the product and send either by courier or insured mail with shipping and insurance prepaid to:

For products purchased in the United States:

The Coleman Company, Inc.
3600 North Hydraulic
Wichita, KS 67219 U.S.A.

For products purchased in Canada:

Sunbeam Corporation (Canada) Limited
DBA Jarden Consumer Solutions
20B Hereford Street
Brampton, ON L6Y 0M1

The costs of transporting the product to Coleman or an authorized service center for warranty service is the responsibility of the purchaser.

DO NOT RETURN THIS PRODUCT TO THE PLACE OF PURCHASE.

If you have any questions regarding this warranty please call 1-800-835-3278 or TDD 1-316-832-8707 in the United States or 1-800-387-6161 in Canada.

1 Year Limited Warranty

The Coleman Company, Inc. ("Coleman") warrants that for a period of 1 year from the date of original retail purchase, this product will be free from defects in material and workmanship. Coleman, at its option, will repair or replace this product or any component of the product found to be defective during the warranty period. Replacement will be made with a new or remanufactured product or component. If the product is no longer available, replacement may be made with a similar product of equal or greater value. This is your exclusive warranty.

This warranty is valid for the original retail purchaser from the date of initial retail purchase and is not transferable. Keep the original sales receipt. Proof of purchase is required to obtain warranty performance. Coleman dealers, service centers, or retail stores selling SevyLor® products do not have the right to alter, modify or in any way change the terms and conditions of this warranty.

What This Warranty Does Not Cover

This warranty does not cover normal wear of parts, parts that are not genuine SevyLor® parts, or damage resulting from any of the following: negligent use or misuse of the product; commercial use of the product; use contrary to the operating instructions; disassembly, repair or alteration by anyone other than Coleman or an authorized service center. Further, the warranty does not cover Acts of God, such as fire, flood, hurricanes and tornadoes. Warranty void if damage to product results from the use of a part other than a genuine SevyLor® part.

COLEMAN SHALL NOT BE LIABLE FOR DEFECTS THAT ARE CAUSED BY THE USE OF UNAUTHORIZED PARTS OR SERVICE. COLEMAN SHALL NOT BE LIABLE FOR ANY INCIDENTAL OR CONSEQUENTIAL DAMAGES CAUSED BY THE BREACH OF ANY EXPRESS OR IMPLIED WARRANTY OR CONDITIONS. EXCEPT TO THE EXTENT PROHIBITED BY APPLICABLE LAW, ANY IMPLIED WARRANTY OF MERCHANTABILITY OR FITNESS FOR A PARTICULAR PURPOSE IS LIMITED IN DURATION TO THE DURATION OF THE ABOVE WARRANTY OR CONDITIONS. SOME STATES, PROVINCES, OR JURISDICTIONS DO NOT ALLOW THE EXCLUSION OR LIMITATION OF INCIDENTAL OR CONSEQUENTIAL DAMAGES OR LIMITATIONS ON HOW LONG AN IMPLIED WARRANTY LASTS, SO THE ABOVE LIMITATIONS OR EXCLUSION MAY NOT APPLY TO YOU. THIS WARRANTY GIVES YOU SPECIFIC LEGAL RIGHTS, AND YOU MAY ALSO HAVE OTHER RIGHTS THAT VARY FROM STATE TO STATE OR PROVINCE TO PROVINCE.

How to Obtain Warranty Service

Take the product to an authorized Coleman service center. You can find the nearest authorized Coleman service center by visiting www.coleman.com or calling 1-800-835-3278 or TDD 1-316-832-8707 in the United States or 1-800-387-6161 in Canada. If a service center is not conveniently located, attach to the product a tag that includes your name, address, daytime telephone number and description of the problem. Include a copy of the original sales receipt. **Carefully package the product and send either by courier or insured mail with shipping and insurance prepaid to:**

For products purchased in the United States:

The Coleman Company, Inc.
3600 North Hydraulic
Wichita, KS 67219 U.S.A.

For products purchased in Canada:

Sunbeam Corporation (Canada) Limited
DBA Jarden Consumer Solutions
20B Hereford Street
Brampton, ON L6Y 0M1

The costs of transporting the product to Coleman or an authorized service center for warranty service is the responsibility of the purchaser.

DO NOT RETURN THIS PRODUCT TO THE PLACE OF PURCHASE.

If you have any questions regarding this warranty please call 1-800-835-3278 or TDD 1-316-832-8707 in the United States or 1-800-387-6161 in Canada.

© 2012 The Coleman Company, Inc. All rights reserved.

QuickPump™ and Double Lock™ are trademarks of The Coleman Company, Inc.

SevyLor® is a registered trademark and  Tahiti™, Rio™, Fastback™, Colorado™, Pointer™ and Fiji™ are trademarks of Sevca, LLC.



3600 North Hydraulic • Wichita, KS 67219 U.S.A.

1-800-835-3278 • www.Sevylor.com

4010006279 (ECN20026736-03)