

Smarter
technology
for all

Lenovo

Lenovo Retail Solutions

Quick and easy self-service



Lenovo Self Service Kiosk | FP-W3

Lenovo Self Service Kiosk is a compact self-service solution applicable to various Retail stores such as supermarkets, convenience stores, restaurants etc., offering consumers more convenient and interactive shopping experience.

Smart Technology with AI drives the Future of Retail

Retailers are increasingly relying on advanced technology solutions for inventory management, personalized marketing through data analytics and AI, and seamless omnichannel platforms. More will deploy AI to enhance decision-making and regulatory compliance in 2025. With the emphasis on robust data management support in AI projects, retailers seek partners for AI expertise and measurable business outcomes.

As a global IT leader, Lenovo is partnering with companies to make sense of AI. Our AI Services is designed to help businesses assess their AI-readiness and address organizational gaps by deploying the right solutions based on their needs and goals—to transform today’s retail experience and bring the future of retail to life.

Business Priorities for 2025	What do Organizations Seek in a Partner?
1 Improving regulatory compliance	1 Support for data management
2 Enhancing decision making	2 AI knowledge & expertise (including scaling AI solutions)
3 Improving employee productivity	3 Ability to help our organization deliver measurable business outcomes
4 Optimizing supply chain inventory	4 Depth of partnerships with AI solution providers (ISVs, alliance partners)

Lenovo Retail Solutions offers a comprehensive AI Services portfolio for a customized and production-ready AI system.

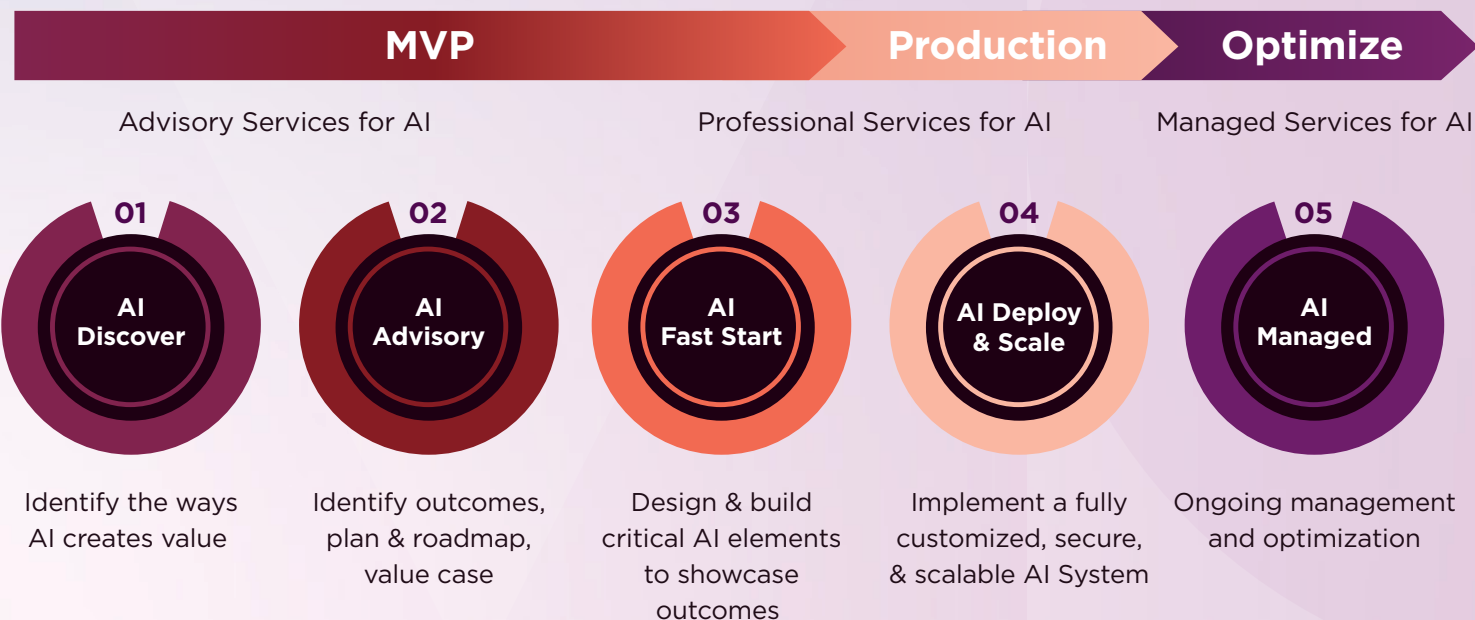

Transform your business from end to end with the **5 Foundations for Smarter Retail.**

Lenovo Retail Solutions provides smart technology solutions **from your storefront to your back office.**

Smart Promotion

Smart Shelving

Smart Checkout

Smart Store Operations

Smart Store Infrastructure

Lenovo Self Service Kiosk is part of the Smart Checkout Solutions that enhances customer engagement and accommodates specific customer requirements, like:



Ordering Products



Booking Transactions



Ticket Collecting



Information Inquiry

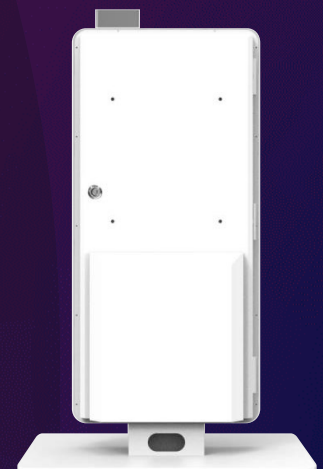
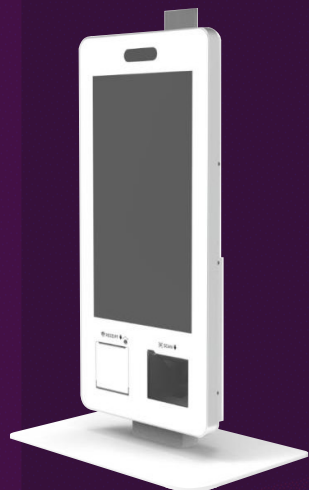
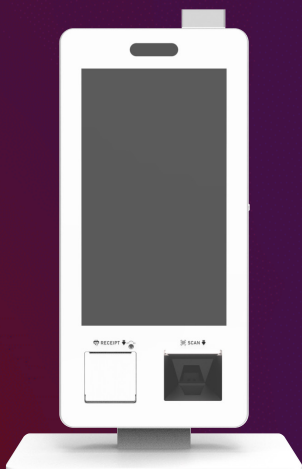

Self-Service Kiosk

- ✓ User-friendly interface and design for ease of use
- ✓ Uses Scan & Go Technology that simplifies ordering, booking, and ticket collection into a compact, easy-to-use package
- ✓ Software agnostic with an open platform to accommodate specific customer requirements

Key Features



Space
Efficient



Full HD
Touchscreen



10-point
Multi-touch



80mm
Receipt Printer



Ultra-clear
tempered glass

1

Flexible Installation

It is a stylish product that's delicate and space-efficient. With its size and different types of accessory, you can install the kiosk almost anywhere you want, such as wall mounted, tabletop or stand type installation etc.

2

Multiple Applications

Lenovo Self-checkout kiosk has many versatile applications including supermarkets, convenience stores, unmanned stores, and department stores.

3

Plentiful Integrated Peripheral Option

Such as POS, lamp post and weighing-appliance that can accommodate dynamic retail scenarios and environment.

4

Support Cashless Payment

Providing customers with faster and smoother payment experience. (Must be applied with software and operation system)

Key Functions



1D/2D Code
Reader



Receipt Printer



Front-opening
door structure



Scan & Go
Verification



Equipment
Status Reminder



Membership
Identification

Product Specs

Screen Parameter	FP-W3
Screen Size	23.8 inch
Touch	10 points G+G Capacitive touch screen, Hardness>6H
Aspect Ratio	16: 9
Resolution	1080 x 1920
Display Area	527.04 x 296.46 mm
View Angle	89/89/89/89 (Typ.)(CR≥10)
Brightness	250 cd/m ²
Contrast Ratio	1000: 1
Color	16.7M, 72% NTSC

System Configuration

CPU	11th Generation Intel® Core™ i5 Processors, 4 Cores, 8 Threads
GPU	Intel® Iris® Xe Graphics
Frequency	Base Frequency 2.6 GHz; Max Turbo Frequency 4.4 GHz
RAM	8 GB
ROM	256 GB
I/O Ports	1*DC, 1*HDMI, 1*VGA, 4*USB, 1*LAN, 1*audio, 1*Mic, 2*COM, 1*Power, 1*AC
Network	LAN: 10M/100M/1000M Self-adaptive; WIFI: 2.4G&5G 802.11 b/g/n/ac
OS	win11 IOT LTSC
Speaker	Build in 4 Ω 3W Speaker
Printer (80mm)	Automatic paper cutting (full cut/half cut); Printing paper width: 80 mm; Printing width: 72 mm; Paper roll specifications: Outer diameter - Ø80 mm (maximum), Inner diameter - Ø13 mm (minimum); Printing Speed: Max 250mm/s; Printing Density: 8 dots/mm; Printing Character: ASCII/GB18030 Simplified Chinese/Multi-language character set/Traditional Chinese
Scanner	1D: UPC-A, UPC-E, UPC-E1, EAN-13, EAN-8, ISBN/ISSN, Code 39, Code 39 (ASCII full code), Code 32, Trioptic Code 39, Interleaved 2 of 5, Industrial 2 of 5, Matrix 2 of 5, Codabar (NW7), Code 128, UCC/EAN 128 (GS1-128), ISBT 128, Code 93, Code 11 (USD 8), MSI/Plessey, UK/Plessey, China Post, China Finance, GS1 DataBar (formerly: RSS) series. 2D: PDF417, MicroPDF417, QR Code, MicroQR Code, DataMatrix, Han Xin Code, Aztec Code, GS1 Composite (GS1 Composite Code).
Input Voltage	AC 100-240V, 50-60Hz
Size	939 x 575 x 362 mm (± 5 mm)
Material	Aluminum frame, sheet metal back cover
Installation	Wall mounted, desktop, Shelf stand
Weight	N.W: 23 kg (kiosk); 14 kg (desktop stand); G.W: 24.64 kg (kiosk); 14.36 kg (desktop stand)
Packing	938 x 537 x 250 mm (kiosk); 590 x 380 x 110 mm (desktop stand)
Working Environment	Working temperature: 0°C - 50°C; Working humidity: 20% - 80%
Storage Environment	Storage temperature: -10°C - 60°C; Storage humidity: 20% - 80%

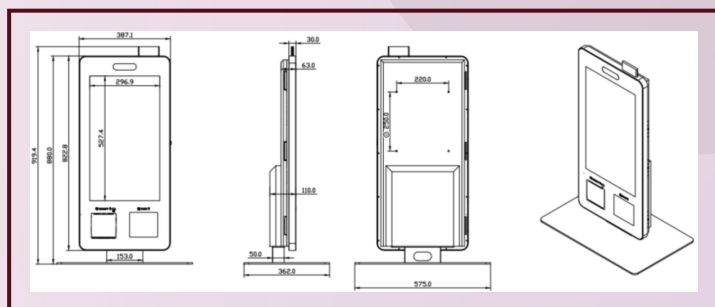

Certifications



*The product information and specifications are subject to change without prior notice. *Please refer to the website for more attachment options.

Lenovo

Smarter
technology
for all

Lenovo



Are you ready to jumpstart your digital transformation journey with **Lenovo Retail Solutions**?

The vision is yours.
Get there with **Lenovo**

Learn more on how: <https://www.lenovo.com/aiservices>

©2024 Lenovo. All rights reserved. These products are available while supplies last. For any questions concerning price, please contact your Lenovo Account Executive. Lenovo is not responsible for photographic or typographic errors. Lenovo makes no representation or warranty regarding third-party products or services. Trademarks: Lenovo, the Lenovo logo, Rescue and Recovery, ThinkPad, ThinkCentre, ThinkStation, ThinkVantage, and ThinkVision are trademarks or registered trademarks of Lenovo.