

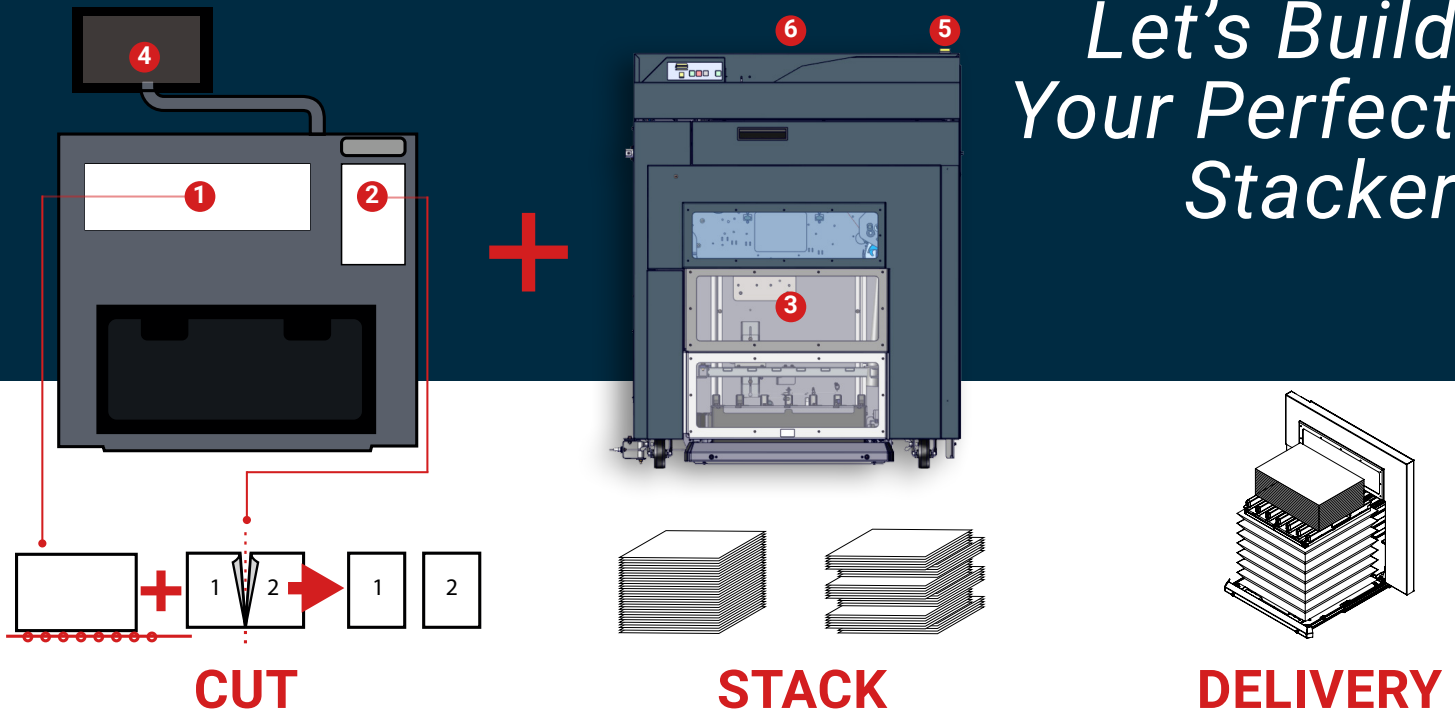

BPS PERFECT STACKER
Sheet Stacking Solutions

Let's Build Your Perfect Stacker



BOURG PERFECT STACK - BPS

1 REGISTRATION AND OPTIONAL ROTATION

The sheet coming from the upstream device is registered in the BPM. It can also be rotated clockwise before registration. The vacuum level for registration is automatically adjusted based on the media type, size, and weight and on whether the rotation is enabled or not.

2 CUT

The BPM cross cuts the sheets perpendicularly to their width into two identical pages. It also creates a gap between these two half sheets to enable sheet processing downstream.

3 STACKING

The BPS is stacking sheets with or without offset to separate sets. Once the stack reaches the maximal capacity, the automatic delivery process is initiated. The delivery process works in an "unload while run" mode, with stacking continuing while a stack is waiting to be picked up by the operator. As soon as that stack is picked up, the stacking table is automatically going back in the BPS.

4 GRAPHICAL USER INTERFACE - GUI

The intuitive color GUI's operating system is icon-based for user-friendly operation. Ergonomically designed to swing left or right and tilt for operator preference. All machines' setups are managed and stored in the GUI for toolless operation.

5 ATTENTION LIGHT

When a stack is ready on the BPS, the attention light on top of the unit starts flashing, the front shutter door opens up, and the delivery table comes out of BPS then up. The attention light changes to solid on to warn the operator that a stack is ready to be picked up.

6 TOP TRAY

The BPS is equipped with a top tray which can be used as a sample tray or to receive diverted sheets thanks to an automatic jam detection process, to help minimize job recovery time.

AUTOMATED STACKING SOLUTIONS

Compact

The C.P. Bourg configuration with the BSF, BPM, and BPS is the ideal compact solution for a 2-Up workflow to quickly get top quality book block stacks. You just then need to load these book blocks in a perfect binder or in a booklet maker.

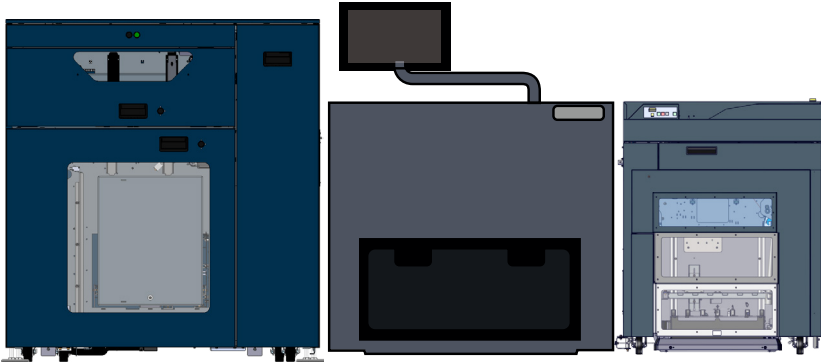

Double BPM and/or Double Stackers

C.P. Bourg products' flexibility enables 4-Up workflows Inline with digital presses. A second BPS enables the « auto-switch » function : once you reach the maximum capacity in a BPS, the other one is stacking the subsequent set, allowing uninterrupted stacking.

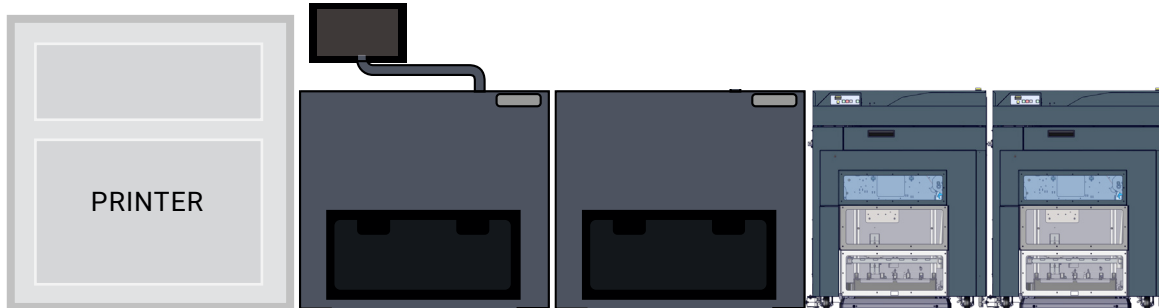

Inline Sheet Feeder Addition

Adding a BSF Sheet Feeder Inline enables the « dual mode » function. This solution combines the full automation of the Inline process with a digital press and the Offline flexibility achieved when loading sheets directly in the BSF.

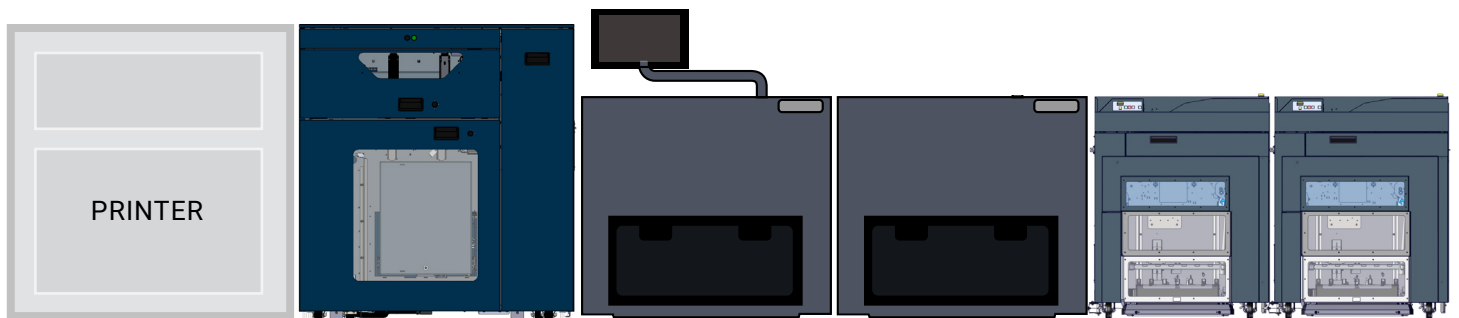

PERFECT BINDING EVOLUTIONS

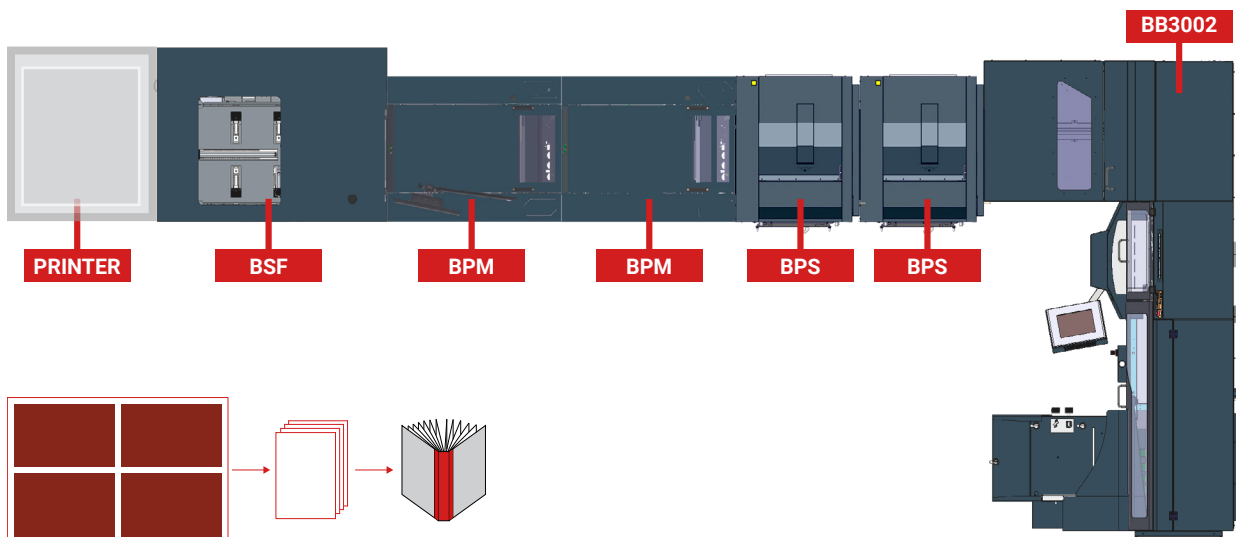

The BPS can be added to a fully automated 4-Up book binding production line. The bypass capability of the BPS guarantees full flexibility: the sheets printed Inline can be bound automatically in a C.P. Bourg BB3002 perfect binder or stacked in the BPS to have them finished in another production machine.

PERFECT BINDING EVOLUTIONS

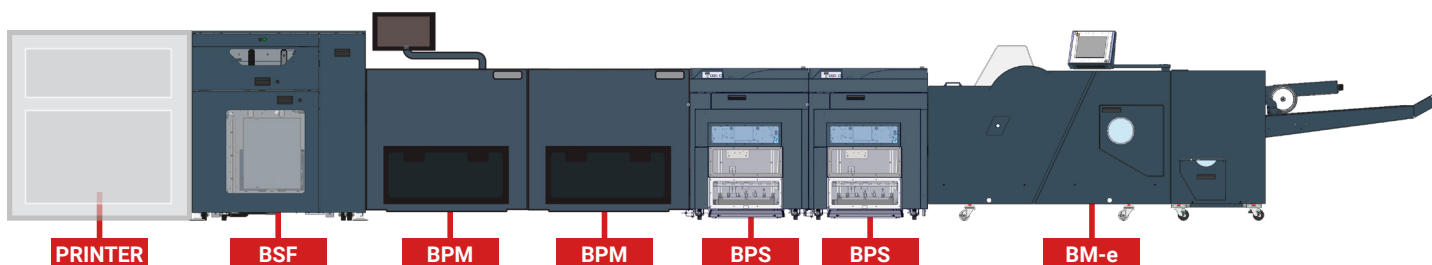

The BPS can be added to a fully automated 4-Up booklet making production line. The bypass capability of the BPS guarantees full flexibility: the sheets printed Inline can be automatically stitched/folded/trimmed in a C.P. Bourg BM-e Booklet Maker or stacked in the BPS to have them finished in another production machine.

TECHNICAL SPECIFICATIONS

Max. Stack Height		250 mm (9.84")	
Paper Weight 2-Up Workflow*		60 to 350 gsm	
Paper Weight 4-Up Workflow*		60 to 170 gsm	
Media Size		BPM (L x H)	BPS (L x H)
Minimum		225 x 320 mm (8.86 x 12.60")	225 x 160 mm (8.86 x 6.30")
Maximum	Without Cut	500 x 364 mm (19.69 x 14.33")	500 x 364 mm (19.69 x 14.33")
	With Cut	600 x 364 mm (23.62 x 14.33")	300 x 364 mm (11.81 x 14.33")

**The quality of the paper may affect the results.*

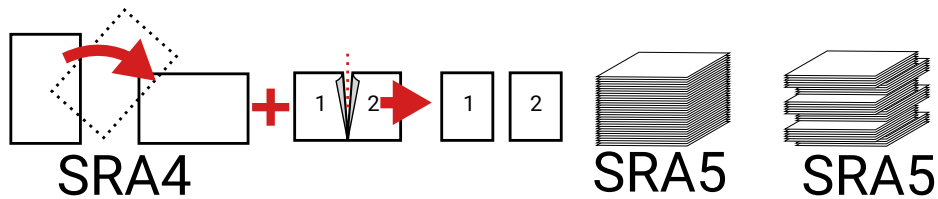
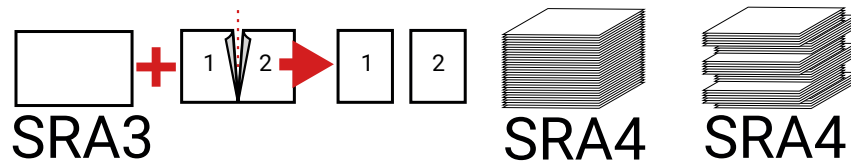

DIMENSIONS

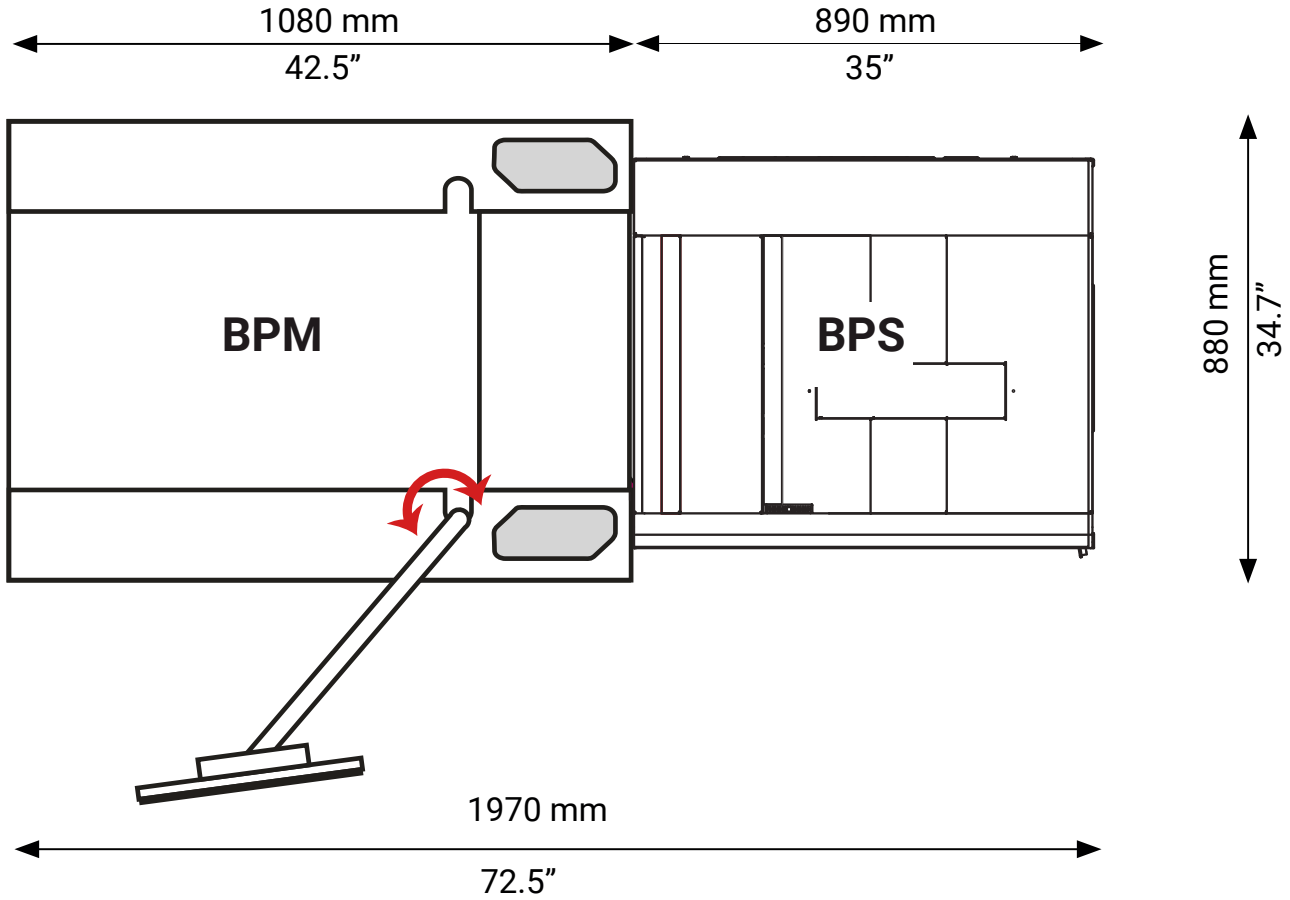

PAPER PATH PROCESS

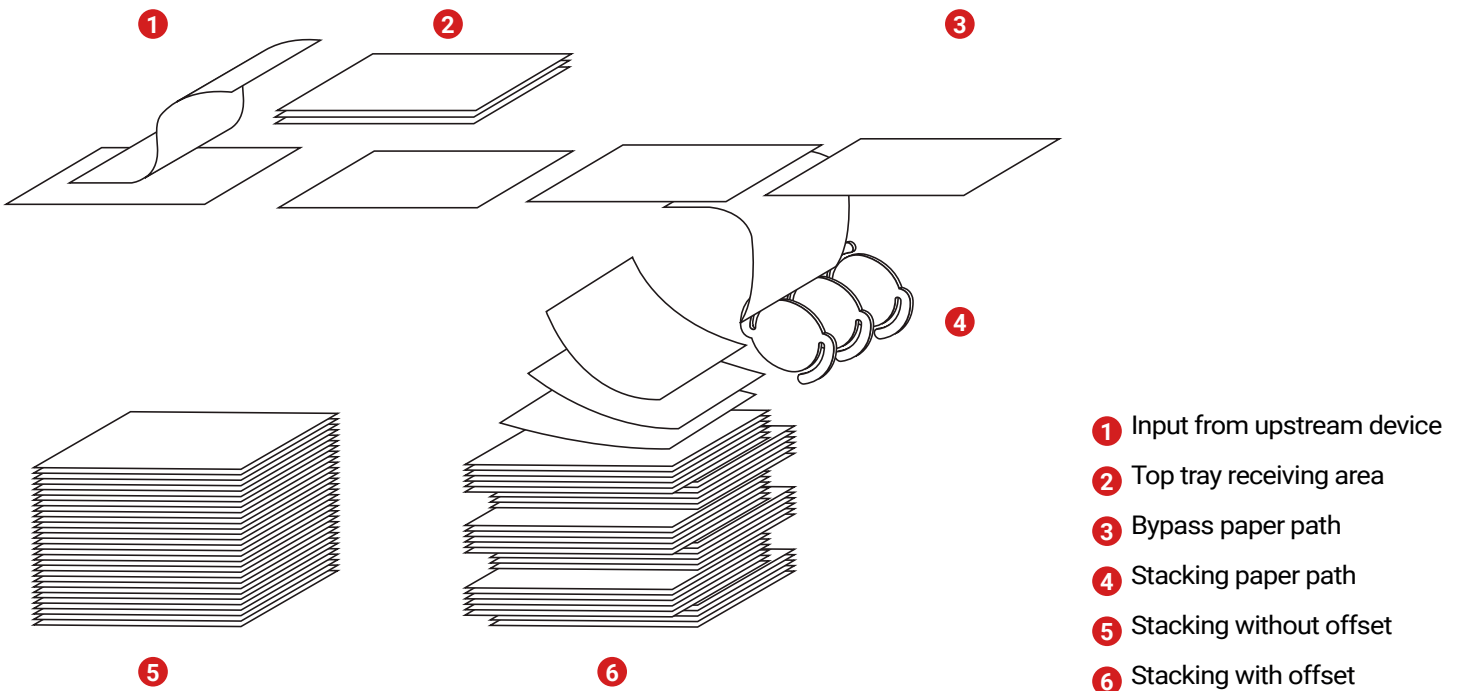

APPLICATIONS

1 BPM
Configurations

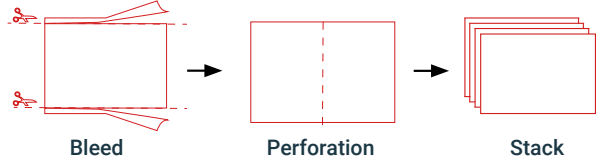
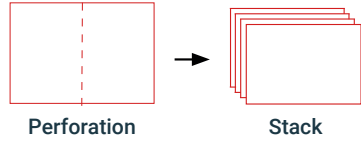
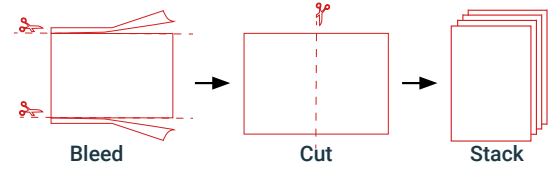
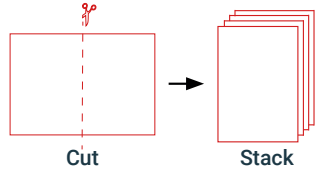

2 BPM
Configuration

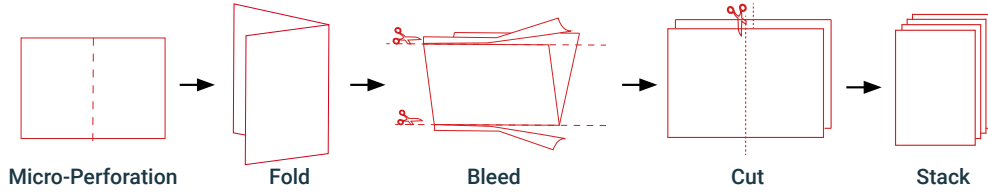

Canon

1-844-50-CANON

usa.canon.com/business